



**EMERGENCY CARCASS MANAGEMENT**  
DESK REFERENCE GUIDE

**FAD PReP**

**Foreign Animal Disease  
Preparedness & Response Plan**



**United States  
Department of  
Agriculture**

United States Department of Agriculture • Animal and Plant Health Inspection Service • Veterinary Services

# Contents

Applicability Statement .....	I
Acknowledgements .....	II

## SECTION 1: RESPONSE PROCESS

Carcass Management Response Process .....	1-1
National Environmental Policy Act (NEPA) .....	1-2
Council on Environmental Quality (CEQ) NEPA Implementing Regulations.....	1-3
USDA NEPA Regulations.....	1-4
APHIS NEPA Implementing Procedures .....	1-5
Operations Procedures.....	1-6

## SECTION 2: DECISION TOOL

Information Needed for Carcass Management Decisions.....	2-1
Definitions .....	2-2
Carcass Management Decision Tool .....	2-4
Carcass Management Decision Cycle.....	2-7
Carcass Management Options Checklists .....	2-8

## SECTION 3: IN-HOUSE COMPOSTING

Overview of In-House Composting Process .....	3-2
Conducting the Farm Assessment for In-House Composting .....	3-2
Protocol for In-House Poultry Compost Windrow Construction.....	3-4
Temperature Monitoring .....	3-8
Turning the Windrows, Release of the Compost, and Composting Manure and Waste Feed.....	3-9
Transition from One SME to the Next During an Event and Troubleshooting.....	3-10
Appendix A: In-House Composting Checklist .....	3-11
Appendix B: Methods of Estimating Carbon (Bulking Agent) Needs .....	3-12
Appendix C: Variations On Typical In-House Poultry Windrow Construction Protocol.....	3-14
Appendix D: Temperature Monitoring Procedure .....	3-17
Appendix E: Temperature Monitoring Log Sheet.....	3-19
Appendix F: In-House Composting Ammonia Safety .....	3-20
Appendix G: Compost Approval Checklists.....	3-21
Appendix H: Windrow Turning Equipment and Methods .....	3-27
Appendix I: Compost Feedstocks .....	3-30
Appendix J: Compost Action Plan.....	3-35
Appendix K: Composting SME Daily Activity Log - ICS-214-CS.....	3-38
Appendix L: 214 Daily Activity Log Report Guidance Document.....	3-40

## SECTION 4: OUTDOOR COMPOSTING

Overview of Outdoor Composting Process.....	4-2
Conducting the Farm Assessment for Outdoor Composting.....	4-3
Recommended Protocol for Outdoor Composting.....	4-4
Temperature Monitoring and Timeline for Turning the Windrows .....	4-10
Release of the Compost and Transition from One SME to the Next During an Event .....	4-11
Composting Manure, Waste Feed, and Other Potentially Infected On-farm Materials.....	4-12
Troubleshooting.....	4-13
Appendix A: Outdoor Composting Checklist.....	4-14
Appendix B: Selecting a Carcass Compost Site .....	4-15
Appendix C: Estimating Carbon (Bulking Agent) Needs.....	4-17

Appendix D: Estimating Space Requirements for Compost Windrows Based on Animal Units.....	4-18
Appendix E: Temperature Monitoring Procedure .....	4-19
Appendix F: Temperature Monitoring Log Sheet.....	4-21
Appendix G: Compost Approval Checklists.....	4-22
Appendix H: Windrow Turning Equipment and Methods .....	4-28
Appendix I: Compost Feedstocks .....	4-31
<b>SECTION 5: OPEN BURNING</b>	
Standard Operating Procedures: Open-Air Burning .....	5-1
Appendix A: Carcass Management: Open-Air Burning Checklist .....	5-3
<b>SECTION 6: BURIAL</b>	
Burial Effect on Environment.....	6-1
Standard Operating Procedures: Unlined Burial .....	6-2
Appendix A: Carcass Management On-Site Burial Checklist .....	6-4
Appendix B: Land Area or Excavation Volume Required for Trench Burial .....	6-5
<b>SECTION 7: MOBILE TREATMENT</b>	
Overview of Mobile Treatment Technologies.....	7-1
Standard Operating Procedures: Air-Curtain Incineration.....	7-2
Carcass Management: Mobile Treatment Checklist .....	7-4
<b>SECTION 8: LANDFILLS</b>	
Carcass Management: Off-Site Permitted Landfill Checklist .....	8-1
Landfill Disposal Guidance—Recommended Waste Acceptance Practices for Landfills .....	8-2
CDC Interim Guidance for Landfill Workers in the United States Disposing of Poultry Carcasses During Outbreaks of Highly Pathogenic Avian Influenza .....	8-6
Standard Operating Procedures: Landfilling .....	8-10
<b>SECTION 9: RENDERING</b>	
Standard Operating Procedures: Rendering.....	9-1
Standard Operating Procedures: Transport.....	9-3
Example Rendering Plant Biosecurity Protocol .....	9-5
Carcass Management: Rendering Checklist .....	9-6
<b>SECTION 10: INCINERATORS</b>	
Carcass Management: Off-Site Incineration Checklist.....	10-1
Standard Operating Procedures: Fixed Incineration .....	10-2
Standard Operating Procedures: Air-Curtain Incineration.....	10-4
<b>SECTION 11: SECURE TRANSPORT</b>	
Loading Procedures .....	11-1
Permit Requirements .....	11-4
Overview of the Eight Steps in Interstate Permitted Movement.....	11-5
Transport Methods in Order of Risk and Containment Types and Risk.....	11-6
<b>SECTION 12: BIOSECURITY</b>	
Safety, Health & Environmental Protection.....	12-1
Personal Protective Equipment .....	12-4
PPE Requirements.....	12-5
Go-Bag Checklist .....	12-6
Temporary Vehicle Wash Station Draft Standard Operating Procedure .....	12-8
Work Zones and Control Areas.....	12-10
Ready Reference Guide—Overview of Zones.....	12-13

**SECTION 13: REFERENCES**

Stop Avian Influenza Outbreaks.....13-1

Fact Sheet 9580.202: Debris Removal.....13-2

National Veterinary Stockpile Ready for Animal Disease Emergencies .....13-3

Questions and Answers: The National Veterinary Stockpile and the 24-Hour Push Pack .....13-4

Questions and Answers: The National Veterinary Stockpile and 3D Response Support Services.....13-5

USDA Avian Influenza Response: Mass Depopulation and Carcass Disposal .....13-6

HPAI Response: Timeline, Eligibility, and Approval for Restocking.....13-7

HPAI Response Mortality Composting Protocol for Avian Influenza Infected Flocks.....13-8

Landfills and Highly Pathogenic Avian Influenza (HPAI) Response .....13-9

North American Renderers Association: Membership Directory .....13-10

Risk Assessment for the Transmission of Foot and Mouth Disease via Movement of Swine  
and Cattle Carcasses from FMD-infected Premises to a Disposal Site.....13-11

## Applicability Statement

This guide is intended to be used by the Disposal Group Supervisor or designee on a USDA APHIS Incident Management Team during an animal health emergency response.

# Acknowledgements

The compilation of the Disposal Guidebook was a collaborative effort. Many individuals contributed their time and talents to this project. We wish to thank the following people who made this manual possible:

## **PROJECT MANAGEMENT**

Elizabeth Clark  
Nicola L. Ritter, MEd, PhD  
Jodi Korich, DVM  
Danelle Weaver  
Michelle Wiederhold, MEd  
Molly Gonzales, MEd, EDD  
Audrey Fidler

## **CONTENT AUTHORS**

Lori P. Miller, PE (retired)  
Rob Miknis, USDA, APHIS  
Jose Gallegos, USDA, APHIS

## **CREATIVE TEAM**

Suzanne Kabat  
Vince Chihak  
Tim Ponder  
Dan Shuta

## **REVIEWERS**

Joanna Davis, DVM  
Tyler McAlpin, DVM, MS  
Julie Gauthier, DVM, MPH  
Rob Miknis, USDA, APHIS  
Mark Hutchinson, University of Maine, Cooperative Extension  
Gary Flory, Virginia Dept of Environmental Quality  
Jose Gallegos, USDA, APHIS

## **EDITOR/CONTENT REVIEW**

Bill Seekins, Maine Department of Agriculture (retired)



This guidebook was compiled by Texas A&M University, College of Veterinary Medicine & Biomedical Sciences through a cooperative agreement with the United States Department of Agriculture, under Agreement No. 15-9100-1492-CA and updated under Agreement No. AP21VSSP0000C075.

## Carcass Management



Note: NAHLN = National Animal Health Laboratory Network

NVSL = National Veterinary Services Laboratories

## National Environmental Policy Act (NEPA)

---

NEPA, as amended, is the cornerstone of environmental protection legislation in the United States. The Act, signed into law in 1970, established this country's national environmental policy and a process to implement it. NEPA requires federal agencies to assess the environmental effects of their proposed actions prior to making decisions.

Federal agencies are required to include a detailed statement for every action significantly affecting the human environment. This statement includes the following five fundamental aspects:

1. the environmental impact of the proposed action,
2. any adverse environmental effects which cannot be avoided should the proposal be implemented,
3. alternatives to the proposed action,
4. the relationship between local and short-term uses of the human environment and the maintenance and enhancement of long-term productivity, and
5. any irreversible and irretrievable commitments of resources which would be involved in the proposed action should it be implemented. (42 U.S.C. § 4332(1)(C))

NEPA established the President's Council on Environmental Quality (CEQ) to create regulations and develop guidance to aid agencies with NEPA compliance. CEQ regulations for implementing the procedural provisions of the NEPA are found under [40 Code of Federal Regulations \(CFR\) parts 1500-1508](#) and are binding on all federal agencies. These regulations require agencies to consider NEPA early in their planning process and to integrate the Act into their decision-making.

The CEQ regulations also consider the content and purpose of an environmental assessment (EA). The primary purpose of an EA is to support the preparation of a finding of no significant impact (FONSI), which is what determines whether an EIS is needed. When a FONSI cannot be determined by the Agency, an EIS will need to be written.

The NEPA statute requires affected agencies to enact their own regulations and procedures in order to ensure environmental issues are considered prior to the implementation of projects. The USDA and APHIS NEPA Implementing Procedures supplement the CEQ implementing regulations and are found under [7 CFR part 1b](#) and [7 CRF part 372](#), respectively. The initial subsections of the APHIS Implementing Procedures present the purpose, identify the chain of command for overall review of NEPA compliance, identify an Agency contact, and provide APHIS-specific definitions. The later subsections discuss early planning, consultation, decision points and public involvement, processing and use of environmental documents, and any supplementing EIS.



## Council on Environmental Quality (CEQ) NEPA Implementing Regulations

---

[CEQ Regulations](#) standardize the NEPA process across agencies and help them prepare environmental analyses. These regulations require the agencies to consider NEPA early in their planning process and to integrate the Act into their decision-making.

CEQ regulations primarily focus on the determination of the need for, the preparation of, and the processing of an environmental impact statement (EIS). These regulations include procedural guidance on when to prepare an EIS, how to cooperate with other agencies during the NEPA process, how to determine the range of issues and alternatives during scoping, and how to involve the public (including specific time limits for public review). The regulations provide format requirements, page limits, the need for plain language, and guidance for incorporation by reference in the supporting assessments and documents. These regulations state the need to address public comments in the document, as well as responding to comments from those affected by a proposed action.

To a lesser degree, the CEQ regulations also consider the content and purpose of an environmental assessment (EA). The primary purpose of an EA is to support the preparation of a finding of no significant impact (FONSI), which is what determines whether an EIS is needed. When a FONSI cannot be determined by the Agency, an EIS will need to be written.

# USDA NEPA Regulations

---

The [USDA NEPA Implementing Regulations](#) adopt, incorporate, and supplement those from the CEQ.

The policy of the USDA NEPA regulations states:

- a. USDA agencies carry out their programs for the purpose of encouraging sufficient and efficient production of food, fiber, and forest products; proper management and conservation of the Nation's natural resources; and the protection of consumers through inspection services;
- b. All policies and programs of Agencies shall be planned, developed, and implemented to achieve the goals and follow the procedures of NEPA;
- c. Each USDA agency shall comply with NEPA and CEQ regulations, including the preparation and implementation of procedures and processes relating to the individual agency activities;
- d. The Under Secretary of Natural Resources and Environment is responsible for ensuring that agency implementing procedures are consistent with CEQ's NEPA regulations and for coordinating the Department's NEPA compliance ([7 CFR 1b.2](#)).

For more information see:

[Authority/Under Secretary \(7 CFR § 2.22\)](#)

# APHIS NEPA Implementing Procedures

---

The [APHIS procedures](#) to implement the NEPA responsibilities are codified at 7 CFR § 372. The initial subsections present the purpose, identify the chain of command for overall review of NEPA compliance, identify an Agency contact, and provide APHIS-specific definitions. The later subsections discuss early planning, consultation, decision points and public involvement, processing and use of environmental documents, and any supplementing EIS.

Implementing Procedures: APHIS recognizes actions as those that (a) normally require an EIS, (b) normally require an EA but not necessarily an EIS, and (c) those that are subject to categorical exclusion (CatEx). However, an EIS or an EA will be prepared if the APHIS decisionmakers determine that an action that would normally be categorically excluded from NEPA analysis may have the potential to significantly affect the quality of the human environment. In general, issues requiring a programmatic (broad) response or planning will trigger the preparation of an EIS. This is particularly true for actions that involve long-term and strategic plans for programs with substantial impacts over large geographic areas, whether national or regional. An EA is considered appropriate when impacts arise from a program action that can be characterized as limited in site, species, time, or activities. If a FONSI cannot be determined, then an EIS is required.

Any action that is categorically excluded from NEPA may have associated measures to avoid or minimize adverse impacts. A CatEx is divided into four major groups: routine measures, research and development, licensing and permitting, and rehabilitation of facilities.

For more information, see:

[Authority/APHIS](#)

# Operations Procedures



Ensure state environmental agency has approved disposal method in writing (see list of state contacts available at [go.usdatraining.com/agencies](http://go.usdatraining.com/agencies)).

## OPERATIONAL TIMELINE FOR DISPOSAL

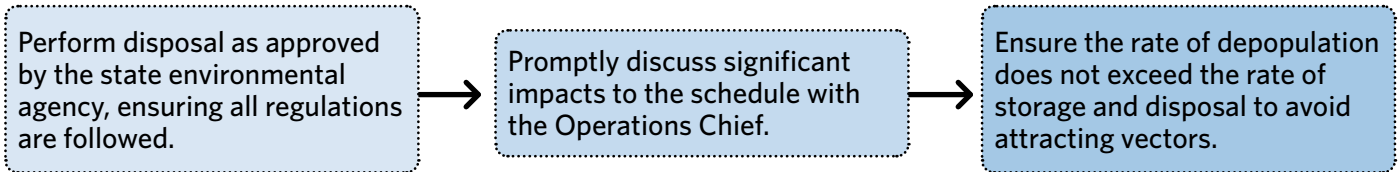

## QUALITY ASSURANCE/QUALITY CONTROL

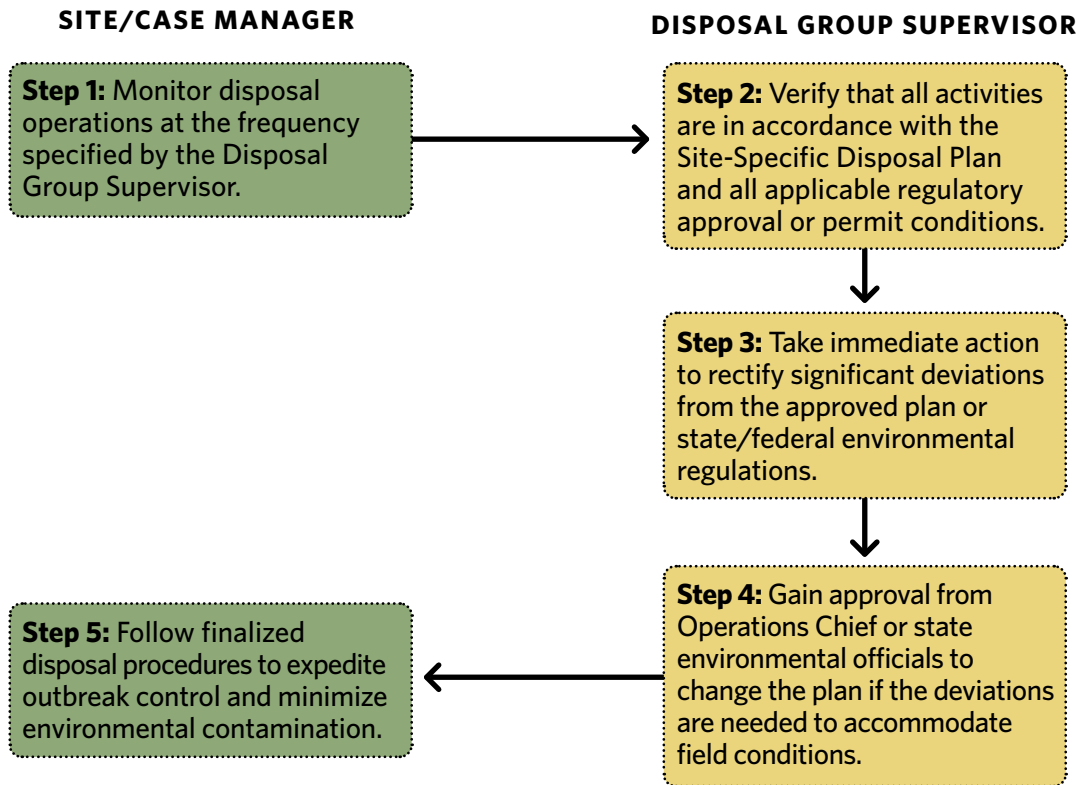

## DEMOBILIZATION

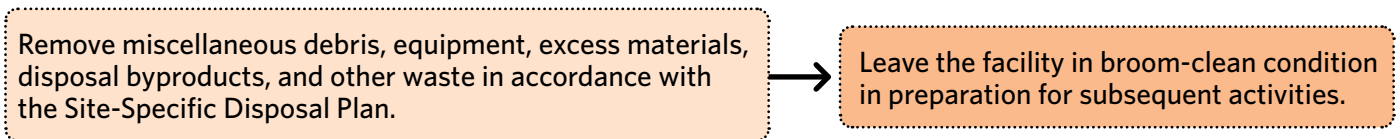

Developed by Texas A&M University  
 Source: USDA FADPreP Disposal SOP [go.usdatraining.com/SOP\\_disposal](http://go.usdatraining.com/SOP_disposal).

## Information Needed to Make Carcass Management Decisions

Date of confirmation: \_\_\_\_\_ Farm Premise ID: \_\_\_\_\_ Plan Date \_\_\_\_\_

Farm Address: \_\_\_\_\_

Points of Contact: Case Manager: Name: \_\_\_\_\_ Contact Info: \_\_\_\_\_

Premise staff: Name: \_\_\_\_\_ Contact Info: \_\_\_\_\_

### Premise Type: Poultry:

Species	Layer	Broiler	Pullet	Turkey	Breeder: chicken	Breeder: Turkey	Pheasant	Duck	other
# of Animals									

Notes: \_\_\_\_\_

Depopulation Method: \_\_\_\_\_

Compost Options: In-barn:  Outside:

In-Barn: Number of barns \_\_\_\_\_ Barn Configuration: Open span:  Post & beam:

Barn No.	Ceiling Height	Width	Length	Door height and width	Number of Animals	Type/ Age of animal	Ave. Wt.	Depth of litter	Moisture 1-dry 5-wet	Texture 1-fine 5-coarse	Feed volume

Notes: \_\_\_\_\_

### Outside Compost Operation:

# of Barns	Land Available (acres)	Location: Onsite or Offsite:	Site approval by state: Yes, no, pending	Land Use ownership agreement	Manure volume & location	Moisture 1 - dry 5- wet	Texture 1-fine 5-coarse	Feed Volume

# of Feed Bins: \_\_\_\_\_ Bin Height: \_\_\_\_\_ Bin Diameter: \_\_\_\_\_ Avg. % Full: \_\_\_\_\_

Eggs: How Many: \_\_\_\_\_ Condition: \_\_\_\_\_ Packaging: \_\_\_\_\_

Water Available: Yes: \_\_\_\_\_ No: \_\_\_\_\_ If yes: describe source: \_\_\_\_\_

Name of Contractor: \_\_\_\_\_ Experience: \_\_\_\_\_

If Farmer will construct, then describe equipment, experience: \_\_\_\_\_

Windrows: Average Length: \_\_\_\_\_ Height: \_\_\_\_\_

Anticipated turning method: \_\_\_\_\_ (skid steer, loader, tractor, windrow turner, other)

Notes and Comments: \_\_\_\_\_

## Definitions

---

<b>Animal Unit (AU)</b>	An Animal Unit consists of 1000 pounds of animal weight.
<b>Biomass</b>	The total quantity or weight of livestock/poultry carcasses and associated biodegradable material requiring management.
<b>Capacity</b>	Equal to throughput times availability where throughput is the amount of biomass that can be processed per day per system and availability is the number of systems available.
<b>Composting</b>	A natural biological decomposition process that takes place in the presence of oxygen (air). Composting process control parameters include the initial ratios of carbon and nitrogen-rich materials, the amount of bulking agent added to assure air porosity, the pile size, moisture content, and turning frequency.
<b>Depopulation</b>	Also known as culling, destruction, and/or euthanasia. A method by which large numbers of diseased and/or suffering animals are killed quickly and efficiently with as much consideration given to the welfare of the animals as practicable. It may be practiced during an animal health emergency, such as a major disease outbreak, to eliminate animal suffering or help prevent or mitigate the spread of the disease through the elimination of infected, exposed, or potentially exposed animals. It also serves to remove contaminated livestock from the food supply, protect the nation's agricultural and national economy, and safeguard public health. Animals should not be depopulated until a disposal plan is in place.
<b>Groundwater</b>	Water below the land surface in a zone of saturation.
<b>Leachate</b>	Any liquid material that drains from land, waste, or stockpiled material and contains significantly elevated concentrations of contamination derived from the material it has passed through.
<b>Mobile Incinerators</b>	Air curtain burners, truck or trailer mounted incinerators and similar devices in which incineration is contained and controlled. Pyres do not qualify as mobile incinerators.
<b>Off-site (Fixed-Facility) Incinerators</b>	These include (a) small on-farm incinerators, (b) small and large incineration facilities, (c) crematoria, and (d) power plant incinerators. Unlike open-air burning and air-curtain incineration, fixed-facility incineration is wholly contained and, usually, highly controlled.
<b>On-site Burial</b>	In the context of this document: refers to excavating a trench or pit into the earth more than 6 feet deep, placing carcasses in the trench, and covering with the excavated material (backfill).
<b>On-Site Particle Reduction</b>	On-site particle reduction is the manual or mechanical cutting, grinding, or crushing of the carcass to decrease the dimensions of the resultant parts for ease of handling, to decrease volume, or to enhance further processing.
<b>Open-Air Burning</b>	This includes burning carcasses (a) in open fields, (b) on combustible heaps called pyres, and (c) with other burning techniques that are unassisted by incineration equipment.
<b>Pathogens</b>	Any organism capable of producing disease or infection.

<b>Permitted Landfills</b>	Modern Subtitle D landfills that are highly regulated operations, engineered and built with technically complex systems specifically designed to protect the environment and include liners and leachate controls. These landfills are distinguished from older landfills in the U.S. (sometimes called small arid landfills) which were constructed before Subtitle D regulations were effective, and therefore were not constructed with sophisticated containment systems.
<b>Premises</b>	Geographically and epidemiologically defined locations, including a ranch, farm, stable, or other establishment.
<b>Pyres</b>	Structures, usually made of wood, for burning carcasses.
<b>Rendering</b>	The process by which purified fat and protein products are recovered from inedible portions of animals by cooking at high temperatures.
<b>Shallow Burial with Carbon (SBC)</b>	The practice of placing a carcass or carcasses in a shallow trench (20 to 24 inches deep) on a 1-foot bed of carbonaceous material and then covering with soil. (This practice is also known as Above Ground Burial or AGB.)
<b>Slaughter</b>	The killing of an animal or animals for human consumption.
<b>Stamping Out</b>	The depopulation of clinically affected and in-contact susceptible animals.
<b>Waste</b>	Loosely defined as material that cannot be used for its intended purpose.
<b>Vaccination to Live</b>	The depopulation of clinically affected and in-contact susceptible animals and vaccination of at-risk animals, without subsequent depopulation of vaccinated animals.
<b>Vaccination to Slaughter</b>	The depopulation of clinically affected and in-contact susceptible animals and vaccination of at-risk animals, with subsequent depopulation of vaccinated animals.

# Carcass Management Decision Tool

---

## Matrix, Decision Loop, Checklist (MLCh)

*Developed by USDA APHIS in collaboration with the DHS S&T Depopulation, Disposal, and Decontamination (3D) Program and federal interagency 3D Integrated Product Team (IPT).*

### CONTACT:

[Robert.a.miknis@usda.gov](mailto:Robert.a.miknis@usda.gov)

Rob Miknis  
2150 Centre Ave, Bldg B  
Fort Collins, CO 80526  
O: 970-494-7471  
C: 970-617-8555

[Jose.Gallegos@usda.gov](mailto:Jose.Gallegos@usda.gov)

Jose Gallegos  
4700 River Road  
Riverdale, MD 20737  
C: 575-728-5219

APHIS website for training modules and online interactive tool: [go.usdatraining.com/Disposal](http://go.usdatraining.com/Disposal)

**NOTE:** The following matrix represents the committee's analysis of disposal options using a weighted criteria for each section. The purpose of the weighted factor is to provide more value or benefit when comparing each element. The higher weighted criteria favors public and environmental health.



**DECISION TOOLS**

Weighting	Criteria	Off-Site Landfill	Rendering	Off-Site Incineration*	Composting	Open-Air Burning	On-Site Burial**
Most Important (x3)	Public Health Risk <sup>1</sup>	9	9	9	9	6	3
	Biosecurity <sup>2</sup>	6	6	6	3	3	3
	Pathogen Inactivation <sup>3</sup>	3	6	9	6	9	3
	Environmentally Sustainable <sup>4</sup>	9	9	9	9	3	3
Important (x2)	Need to Transport Carcasses Offsite <sup>5</sup>	2	2	2	6	6	6
	Volume Reduction <sup>6</sup>	4	6	6	4	6	4
	Availability <sup>7</sup>	6	4	2	4	4	4
	Throughput <sup>8</sup>	6	6	2	4	4	4
	Speed to Implement <sup>9</sup>	6	4	4	4	4	4
	Public Acceptance <sup>10</sup>	6	4	6	4	2	4
Less Important (x1)	Cost Effectiveness <sup>11</sup>	3	2	1	1	1	3
	Efficiency <sup>12</sup>	3	3	3	2	1	2
	Operability <sup>13</sup>	3	3	3	2	1	3
	Regulatory Limitations <sup>14</sup>	2	3	2	2	1	1
	Denial of Use <sup>15</sup>	3	2	2	2	2	1
Total Points		71	69	66	62	53	48
Average Score		4.7	4.6	4.4	4.1	3.5	3.2

**Color Key and Matrix Explanation**

IDEAL Green technologies were scored 3 points    
 NOT IDEAL Yellow technologies were scored 2 points    
 NOT SUITABLE Red technologies were scored 1 point

*Scores were weighted according to the importance of the criteria. Scores for each column were totaled then averaged to obtain the ranking.*

# Matrix Footnotes

*Mobile, new, or innovative technologies are not included in this matrix, but a separate table for such technologies is under development.*

*Values in matrix may be incident specific.*

1. **Public health risk** - based on the UK 2001 human health qualitative risk assessment which excluded composting and mobile technologies. The rankings are consistent with the public health risks tabulated by the United Kingdom (UK) Department of Health (now the Department for Environment, Food and Rural Affairs), in *A Rapid Qualitative Assessment of possible risks to Public Health from current Foot & Mouth Disposal Options, Main Report*, June 2001.
2. **Biosecurity** - if process can be contained and easily disinfected = 3, if process is somewhat contained, but the processing area is difficult to disinfect = 2, if process is not contained = 1
3. **Pathogen inactivation** - if process completely inactivates pathogen = 3, partial inactivation = 2, no inactivation = 1
4. **Environmental sustainability** - low risk of environmental contamination and useful end product = 3, low risk of contamination or useful end product = 2, risk of environmental contamination and no useful end product = 1
5. **Transport carcasses offsite** - Yes = 1, No = 3
6. **Volume reduction** - process reduces volume of biomass = 3, same volume = 2, increases volume = 1
7. **Availability** - option is widely available = 3, regional or somewhat available = 2, very limited availability = 1
8. **Throughput** - the amount of biomass that can be processed per day. If >200K lbs/day = 3, between 200K lbs/day - 50K lbs/day = 2, <50K lbs/day = 1. *Note: Throughput X Availability = Capacity*
9. **Speed to implement** - how quickly can option begin taking first carcasses including obtaining regulatory approval where immediately = 3, <5 days = 2, more than 5 days = 1
10. **Public acceptance** - likelihood of public protests where low = 3, medium = 2, and high = 1
11. **Cost effectiveness** - cost to perform option from *K State Carcass Disposal: A Comprehensive Review* where <\$100/ton = 3, \$100/ton - \$250/ton = 2, > \$250/ton = 1
12. **Efficiency** - amount of inputs (utilities, chemicals, fuel, carbon source) to contain and stabilize biomass over a short period of time
13. **Operability** - ease of implementation, for example simple to do, operators readily trained and available
14. **Regulatory limitations** - permits or regulator exemptions would have to be obtained in order to utilize this disposal method
15. **Denial of use** - land or equipment is no longer able to be used for its intended purpose due to disposal method
16. \*Mobile incineration technology is being investigated by USDA as of October 2023. This technology is not yet incorporated into this evaluation.
17. \*\*Shallow Burial with Carbon (SBC) methodology is still being investigated as of Oct 2023. This method has successfully been used, but only in limited conditions..

# Carcass Management Decision Cycle



This decision cycle is intended to guide users in selecting the most appropriate disposal method for managing infected carcasses. This cycle takes into consideration most beneficial use, risk of disease spread, and the environment. The cycle aims to guide decision making with the animal and its intended use, followed by what other derived beneficial use of the carcass, while balancing the risk of viral spreading (on site vs. off site). *NOTE: The order of options in the Carcass Management Decision Cycle differs from the Matrix because on-site options are preferable to disease management officials.*

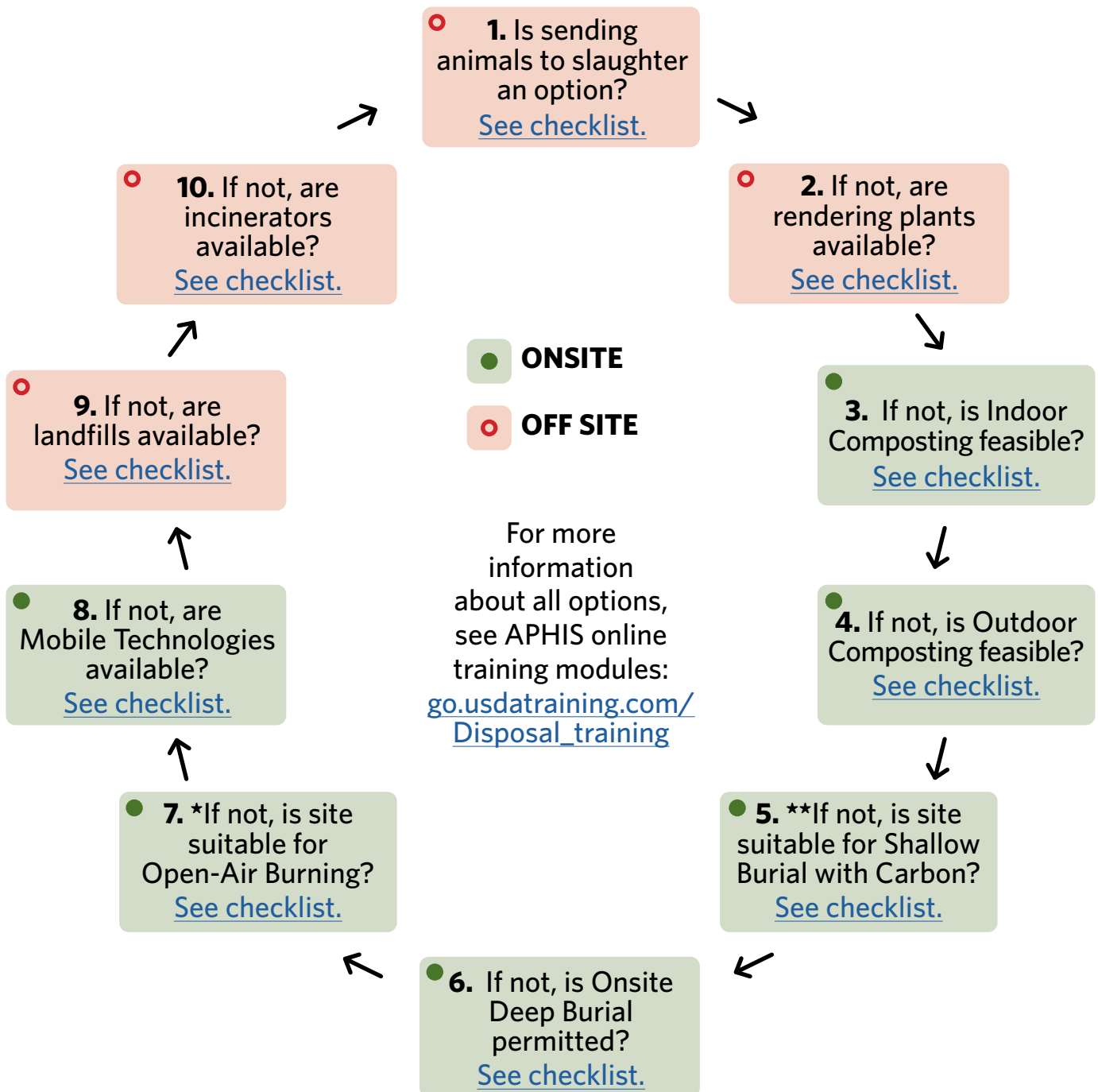

\*Mobile incineration technology is preferred method of burning. However, at this time the development and procedure of using has not been established. It will be included in the future.

\*\* Shallow Burial with Carbon (SBC) methodology is still being investigated as of Oct 2023. This method has successfully been used, but only in limited conditions.

## Carcass Management Options Checklists

---

The following checklists guide users in the feasibility and the use of the various disposal methods. The checklist follows the Carcass Management Decision Cycle, provided on the previous page, in finer detail.

### First Option - Is sending animals to slaughter an option?

- Will USDA APHIS and local and state authorities allow movement of live animals off site?
  - Are there state or local permitting requirements needed for moving live animals?
  - Is public perception of moving potentially diseased animals a concern?
- Is suitable and sufficient trucking available for securely moving live animals?
- If so, are there slaughter facilities within a reasonable trucking distance?
- Do slaughter facilities have capacity to handle the volume of animals?
  - What are the requirements/limitations set by facilities for receiving animals?
- If slaughter is an option, proceed to investigate process for implementing.  
If not, continue to the next option.

**Second Option - Is rendering available?**

- See a complete list of renderers at [go.usdatraining.com/NARA](https://go.usdatraining.com/NARA).
- Contact facilities and determine if they will accept your livestock or poultry and meet some or all of your capacity needs.
  - If the capacity is less than needed, can the carcasses be stored/refrigerated while awaiting disposal?
- If so, arrange for biosecure storage and transport to rendering facility for disposal.
  - Determine if any permits are required for transport of infected carcasses.
  - Determine type of transport vehicles required. If the waste must be transported on public roads, it should be transported in closed, leak resistant trucks or dumpsters. Secondary containment may be needed, depending on the type of waste being transported. Request assistance from the National Veterinary Stockpile through the Incident Management Command Team Logistics Branch.
  - Work with Depopulation Group Supervisor within the Incident Command System to determine how many animals can be depopulated per day and how many trucks will be needed for transport per day, ensuring the rates are about equal. If not, arrange for leak-resistant, covered storage.
  - Pre-identify transport routes to minimize exposure of susceptible premises.
- If rendering is an option, see the Secure Transport and Off-Site Treatment/Burial training modules at [go.usdatraining.com/Disposal\\_training](https://go.usdatraining.com/Disposal_training) and implement rendering. If not, continue to the next option.

### Third Option - Is indoor composting feasible?

- Based on the opinion of an animal mortality composting subject matter expert (SME) are the site conditions suitable for in-house composting of the number of animals affected?
  - See [USDA Mortality Composting Protocol for Avian Influenza Infected Flocks](#) or [USDA Livestock Composting Protocol](#) (also at [go.usdatraining.com/HPAI](http://go.usdatraining.com/HPAI)).
  - Poultry houses or barns have sufficient interior space to maneuver composting equipment and construct windrows. (E.g., enough open space and ceiling height to allow loaders to construct windrows 6-8 feet high and 12 feet wide. Houses with columns, such as double-deck hen houses, can impede/restrict windrow construction.)
  - Poultry houses are located in an area that is accessible by trucks delivering carbon sources. Carbon source could be carbon material; equipment to remove all compostable material; and construct windrow.
  - Poultry houses can be secured against vandals, scavengers, and disease vectors such as wild birds.
- Perform calculation to determine required space for composting is adequate.
- If the poultry houses or barns are suitable, consider the duration of time it takes to fully compost and determine if the following issues can be overcome:
  - Personnel required to ensure proper construction, maintenance, and temperature monitoring of windrows.
  - Need for pest management (such as rodent or wild bird control).
  - Denial of use of poultry houses or barns while composting (at least 30 days).
- If so, is there a sufficient local supply of carbon source such as wood chips (1-2 pounds carbon source per pound of biomass. 1-2 is ROT; it may be more for larger animals, and/or excessive moisture)?
  - Check with local agencies and organizations to determine if stockpiles of carbon source are available (e.g., parks department NRCS, Forest Service, landscape companies and landfills). Ensure that the carbon source is free of any pests or pathogens which could threaten local species. (See [Carbon Sources for Windrow Construction](#)).
- If so, have you arranged for the necessary personnel, equipment, and supplies to be delivered to the site?
  - Mortality composting SME.
  - Composting supplies and carbon source.
  - PPE.
  - Cleaning and disinfecting (biosecurity) supplies.
  - Hand tools.
  - Heavy equipment (mid-size skid-steer loaders, tractors with bucket loaders).
  - Qualified equipment operators.
- If indoor composting is an option, see the Composting training module at [go.usdatraining.com/composting\\_module](http://go.usdatraining.com/composting_module) and implement composting. If not, continue to the next option.

## Fourth Option – Is outdoor composting feasible?

- Identify a suitable site on premises or in a centralized location in accordance with the checklist items below.
  - If off-site, complete site assessment in addition to secure transportation considerations and approval from State or USDA for permitted movement.
- Based on approval of the State environmental agency and the composting SME, are the site conditions suitable for composting the number of animals affected?
  - See [USDA Mortality Composting Protocol for Avian Influenza Infected Flocks](#) or [USDA Livestock Composting Protocol](#) (also at [go.usdatraining.com/HPAI](http://go.usdatraining.com/HPAI)).
  - Adequate land area to build compost piles (assume (237) 1000-pound cows per acre, (1,185) 200-pound swine or sheep per acre, or (47,500) 5-pound poultry per acre) or refer to Carcass Management Dashboard at [go.usdatraining.com/Disposal](http://go.usdatraining.com/Disposal).
  - Required distance from water wells, surface water bodies (lakes, streams, rivers, etc.), sinkholes, seasonal seeps, or other landscape features that indicate the area is hydrologically sensitive, based on guidance from State environmental officials.
  - Consider all groundwater pathways including the presence of drain tiles, soil characteristics, depth to groundwater, use of groundwater, etc.
  - Located away from neighbors and/or out of sight.
  - Located downwind from neighbors and/or houses.
  - Located away from environmentally-sensitive areas.
  - Located close to the livestock or poultry facility or has clear access for transport.
  - Clear of overhead utility lines.
  - Void of excess water.
  - Located on a gentle slope (1%-4%) so there will be no water ponding.
  - Consider the need for an impermeable base and/or protective cover to prevent leachate generation and migration.
- Perform calculation to determine required space for composting is adequate.
- If the site is suitable, consider the duration of time it takes to fully compost and determine if the following issues can be overcome:
  - Personnel and equipment required to ensure proper construction, maintenance, and temperature monitoring of windrows.
  - Pest management.
  - Potential for extreme weather (e.g., hurricane) to disturb pile.
  - Inability to use the land area while composting.
- If so, is there a sufficient local supply of carbon source such as wood chips (1-2 pounds carbon source per pound of biomass)?
  - Check with local agencies and organizations to determine if stockpiles of carbon source are available (e.g., parks department, NRCS, Forest Service, landscape companies, and landfills). Ensure that the carbon source is free of any pests or pathogens which could threaten local species. See [Carbon Sources for Windrow Construction](#).

- If so, have you arranged for the necessary equipment and supplies to be delivered to the site?
  - Personnel.
  - Composting supplies and carbon source.
  - Personal protective equipment.
  - Cleaning and disinfecting (biosecurity) supplies.
  - Hand tools.
  - Heavy equipment (mid-size skid-steer loaders, tractors with bucket loaders, trucks, containers and covers if transporting, leak-resistant material for lining carcass transport containers if disposal is off site.)
- If composting is an option see the *Composting* training module at [go.usdatraining.com/composting\\_module](https://go.usdatraining.com/composting_module) and implement composting. If not, continue to the next option.

### Fifth Option - Is site suitable for Shallow Burial with Carbon (SBC)\*?

- Based on the opinion of an animal mortality composting subject matter expert (SME) from the APHIS roster, are the site conditions and virus of concern suitable for shallow burial with carbon for the number of animals affected?
  - Will State environmental agency permit burial at the site?
  - Consider soil suitability (see USDA NRCS online Web Soil Survey at [go.usdatraining.com/WSS](https://go.usdatraining.com/WSS) based on guidance from state environmental officials).
  - Consider potential for leachate to contaminate groundwater.
  - Consider all groundwater pathways including the presence of drain tiles, soil characteristics, depth to groundwater, use of groundwater, etc.
  - If so, will land owner accept on-site burial, associated environmental liabilities, and potential loss of property value or use?
  - If on-site shallow burial with carbon is an option, see the Shallow Burial with Carbon protocol and implement. If not, continue to Next Option.
- If on-site shallow burial with carbon is an option, see the [Shallow Burial with Carbon protocol](#) and implement. If not, continue to the next option.

*\*SBC is a relatively new disposal approach. The boundaries and limitations of SBC have not completely been established. Therefore, SBC is considered high risk for virus inactivation or elimination. Consult with SMEs and State for further guidance.*



## Sixth Option - Is site suitable for on-site burial?

- Will state environmental agency permit burial at the site?
  - Consider soil suitability (see USDA NRCS online Web Soil Survey at [go.usdatraining.com/WSS](http://go.usdatraining.com/WSS) based on guidance from state environmental officials?)
  - Obtain written approval from State environmental authority that burial is permitted.
  - Consider potential for leachate to contaminate groundwater.
  - Consider all groundwater pathways including the presence of drain tiles, soil characteristics, depth to groundwater, use of groundwater, etc.
  - Consider potential for the burial site to create a stability or explosion hazard in nearby structures from production of methane.
- If so, is adequate land available for on-site burial? (Assume 1.42 acres per 1000 half-ton cows, 0.28 acres per 1000 swine or sheep, and 0.01 acres per 1000 poultry or use the Options Time and Cost Calculator at [go.usdatraining.com/disposal\\_tools](http://go.usdatraining.com/disposal_tools).)
- If so, will land owner accept on-site burial, associated environmental liabilities, and potential loss of property value or use?
- If on-site burial is an option, see the *On-Site Burial* training module at [go.usdatraining.com/burial\\_module](http://go.usdatraining.com/burial_module) and implement on-site burial. If not, continue to the next option.

## Seventh Option - Are site and materials suitable for open-air burning?

- Will local and State agencies allow open burning at the site?
  - Local Fire Department
  - State Department of Agriculture, Animal Health
  - State Department of Environment or Natural Resources
  - USDA-APHIS
  - USEPA
- Will open burning release air pollutants in compliance with public health standards?
- If so, can the permit conditions, such as measures to control the spread of fire, distance to occupied buildings etc. be met?
  - What environmental testing (e.g., water, ash, soils) are required and at what frequency?
  - How and where will the ash be disposed of?
  - Are weather conditions (e.g., wind and drought) suitable for open are burning?
- If so, will burning be publically acceptable?
- If so, have you arranged for the necessary personnel, equipment and supplies to be delivered to the site?
  - Adequate source of combustible material and fuel to keep the fire going. Verify that type of fuel is acceptable to regulatory agencies.
  - Other equipment including mechanical chains and lifting equipment.
  - Personnel properly trained in the use of this equipment.
  - Fire safety equipment also should be readily available.
- If open-air burning is an option, see *Open-Air Burning* training module at [go.usdatraining.com/open\\_burning](http://go.usdatraining.com/open_burning) and implement on-site open air burning. If not, continue to the next option.

## Eighth Option - Are mobile treatment technologies available for your area?

- Contact all appropriate mobile treatment technology vendors including the USDA Veterinary Stockpile through the Incident Command Team Logistics Branch.
  - Verify the units are available for deployment to your site.
  - Verify your ability to meet all site/utility requirements.
  - Verify units can be fully disinfected after use.
  - Verify the units have adequate capacity to meet your needs.
  - If the capacity is less than needed, can the carcasses be stored/refrigerated while awaiting disposal?
  - Verify the availability of skilled operators and spare parts to keep the units operational.
  - Verify the unit can be set up on the site (e.g., the site has appropriate grading and stable surface to support the weight of the unit).
- If so, is the technology permitted by the State environmental agency?
- If so, can the permit conditions be met?
- If so, can the process byproducts be readily disposed?
- If mobile treatment is an option, see *Mobile Technologies* training module at [go.usdatraining.com/mobile\\_module](https://go.usdatraining.com/mobile_module) and implement. If not, continue to the next option.

## Ninth Option - Can off-site permitted landfill be used?

- Consult with state environmental agency for landfill advice.
- Access a comprehensive list of landfills using the I-WASTE Tool at [go.usdatraining.com/I-WASTE](https://go.usdatraining.com/I-WASTE) or use the Carcass Management Dashboard at [go.usdatraining.com/Disposal](https://go.usdatraining.com/Disposal).
  - Access the [I-WASTE tool website](#).
  - Choose treatment and disposal facilities button.
  - Enter filter criteria such as “facility type” (e.g., rendering, incinerators, or landfill).
  - Note that construction debris landfills are not suitable for carcass disposal, and hazardous waste landfills are not necessary unless the carcasses are contaminated with a hazardous material causing them to be classified as hazardous.
  - Enter State or EPA region, and click “View List of Facilities” button.
- Contact facilities and determine if they will accept your livestock or poultry and meet some or all of your capacity needs.
  - If there is insufficient capacity, consider fast-tracking expansion of existing landfill or permitting of new landfill for this purpose.
  - Consider potential environmental and biosecurity concerns.
  - Verify landfill has no outstanding permit violations.
  - Procure landfill services through appropriate Incident Management Team branch.
- If the landfill will accept the material, arrange for biosecure transport.
  - Obtain controlled movement permit for transport of infected carcasses
  - Determine type of transport vehicles required. If the waste must travel on public roads, it should be transported in closed, leak-resistant trucks or dumpsters. Secondary containment may be needed, depending on the type of waste being transported. See [Landfill Disposal Guidance](#).
  - Work with Depopulation Group Supervisor within the Incident Command System to determine how many animals can be depopulated per day and how many trucks will be needed for transport per day, ensuring the rates are about the same. If not, arrange for covered, leak-resistant storage.
  - Pre-identify transport routes to off-site permitted landfill(s) to minimize exposure to susceptible premises.
- If permitted landfilling is an option, see the *Secure Transport and Off-Site Treatment/Burial* training modules at [go.usdatraining.com/Disposal\\_training](https://go.usdatraining.com/Disposal_training) and implement off-site permitted landfilling. If not, continue to the next option.

## Tenth Option - Is off-site incineration available?

- Contact environmental regulatory authorities to verify operations are not in violation of their air permits.
- Will State environmental agency approve incineration?
- If so, see a complete list of incinerators at the EPA database at [go.usdatraining.com/I-WASTE](https://go.usdatraining.com/I-WASTE).
  - Access the [I-WASTE tool website](#).
  - Choose treatment and disposal facilities button.
  - Enter filter criteria such as “facility type” (e.g. rendering, incinerators, or landfill).
  - Enter State or EPA region, and click “View List of Facilities” button or map facilities.
  - If the facilities are compliant, contact them and determine if they will accept your livestock or poultry and meet some or all of your capacity needs.
- If so, arrange for transport to off-site incineration facility for disposal.
  - Determine if any permits are required for transport of infected carcasses.
  - Determine type of transport vehicles required. If the waste must be transported on public roads, it should be transported in closed, leak-proof trucks or dumpsters. Secondary containment may be needed, depending on the type of waste being transported. For reference, see the [University of Minnesota Risk Assessment](#) which further details the transport process dependent on waste types.
  - Work with Depopulation Group Supervisor within the Incident Command System to determine how many animals can be depopulated per day and how many trucks will be needed for transport per day, ensuring the rates are about equal. If not, arrange for leak-resistant, covered storage.
  - Pre-identify transport routes to minimize exposure of susceptible premises.
- If off-site incineration is an option see the *Secure Transport and Off-Site Treatment/Burial* training modules at [go.usdatraining.com/Disposal\\_training](https://go.usdatraining.com/Disposal_training) or see [fixed incinerator instructions](#) and implement off-site incineration. If not, and you still need to dispose of animals, inform Operations Chief and discuss alternate strategies such as centralized carcass management or vaccination. Return to First Option and repeat cycle until all carcasses can be managed.

## Executive Summary of the Method

Composting is a biological process that results in the natural degradation of organic resources (such as poultry carcasses) by microorganisms. Composting has been successfully used throughout the United States for nearly two decades to control outbreaks of low pathogenicity avian influenza (LPAI) and highly pathogenic avian influenza (HPAI). In-house composting can be accomplished in many poultry houses that are single story and have an open floor area that will allow equipment movement.

Microbial activity within a well-constructed compost pile can inactivate many pathogens. The effectiveness of this inactivation process can be assessed by evaluating compost temperatures, the shape of the time and temperature curves, visual observation of carcass decomposition and the homogeneity of the compost mix.

Successful mortality composting requires the following:

1. A qualified composting expert to guide windrow construction.
2. Trained equipment operators.
3. Availability of appropriate equipment.
4. Sufficient carbon, water, and space.

**If any of these components is lacking, composting is NOT recommended.**



Completed windrow

### SAFETY NOTICE



It is possible for high levels of ammonia to accumulate within closed barns prior to or during carcass management. Maximize natural ventilation by opening the doors and curtains to all the houses containing compost piles. If the structure has a ventilation system, turn system on for 30 minutes before entering. Allow enough time for the houses to air out before entering them. Before entering the structure, wear appropriate personal protective equipment (PPE) as recommended by a qualified safety professional in accordance with site-specific hazard assessment. Close the doors and curtains after completing the temperature readings.

Use the buddy system. Entering a barn with active compost or dead birds requires a two-person team. One person, with a cell phone, stays outside the house to monitor the person inside. Before anyone enters the barn, the monitor writes down the location so it can be given quickly to a 911 dispatcher in case of an emergency.

If the person inside is overcome, the monitor immediately calls 911 for assistance. Under no circumstances does the monitor enter the barn without a Self Contained Breathing Apparatus (SCBA). Do anything possible to increase ventilation inside the building while waiting for rescue personnel.

# Overview of In-House Composting Process

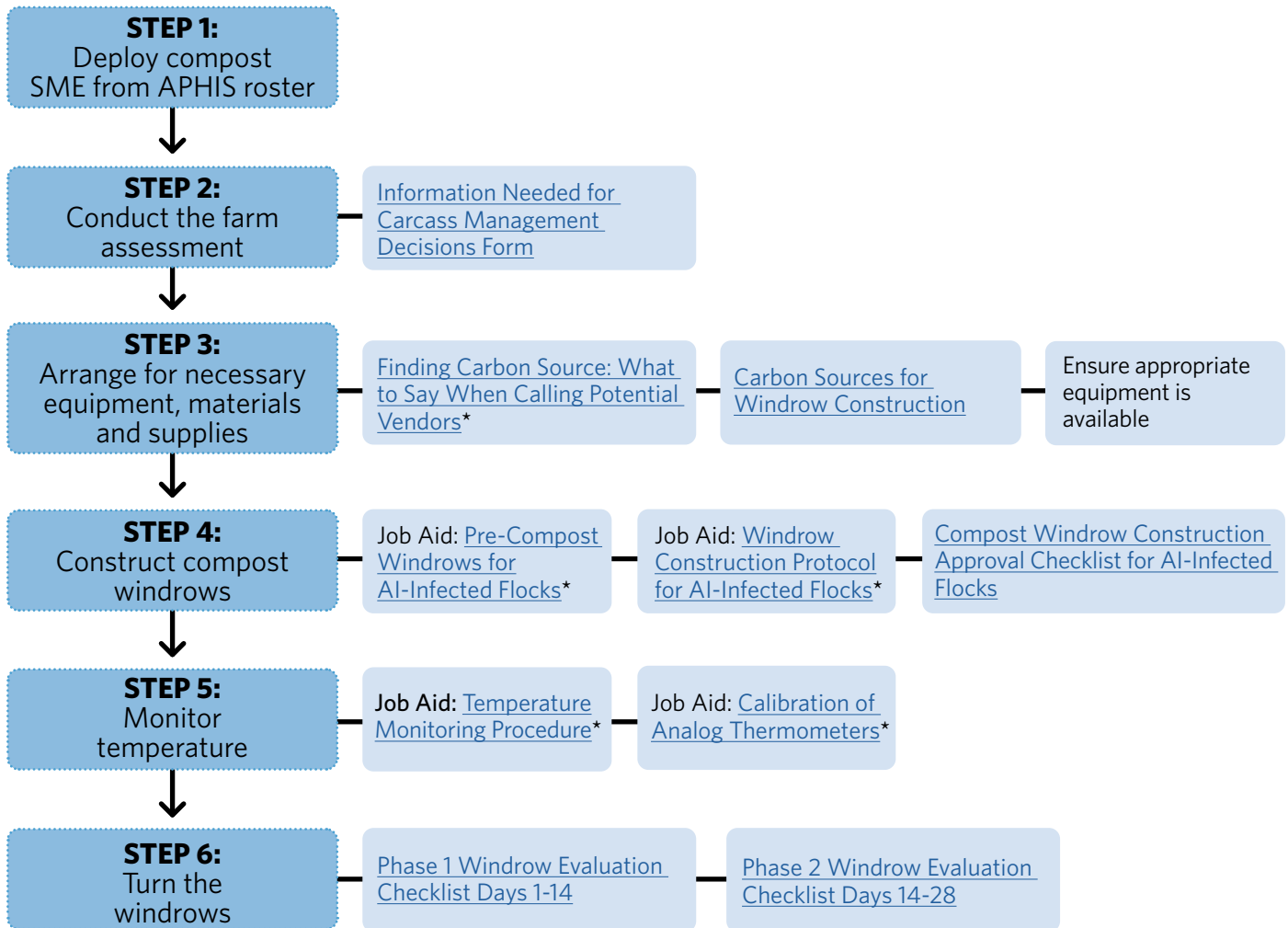

\*Clicking on this link will open the specific resource in a web browser.

## Conducting the Farm Assessment for In-House Composting

In order to plan for windrow construction at the affected premises, a Farm Assessment is required. The Farm Assessment may be provided by the Site Manager or may be developed by a composting Subject Matter Expert (SME) recognized by APHIS. The following components found within the assessment must be completed. (Note: The checklist in [Appendix A](#) may be used as an aid in conducting the farm assessment. Composting approval checklists can be found in [Appendix G](#). A composting site assessment form is currently under development.)

### EVALUATION

1. Evaluate the barn configuration to determine if space is adequate for windrow(s) construction within the poultry barns. If not, assess other on-site structures or outside compost sites. (See [Section 4: Outdoor Composting](#) for details on assessing outdoor sites.)

2. Evaluate the type and quantity of infected materials to be composted, including
  - a. carcass: type, size, number, and condition;
  - b. in-barn manure/litter: volume, moisture content, and density;
  - c. barn width, length and average litter depth (needed for volume estimates);
  - d. stored manure/litter: volume, moisture content, and density;
  - e. routine mortality method, location, and physical condition of mortalities;
  - f. feed: quantity and location;
  - g. eggs: quantity and condition;
  - h. clean bedding; and
  - i. paper products.
3. Calculate the amount of carbon needed for composting (see [Appendix B](#)).
4. Evaluate premises for supplemental water and include the source and application method.
5. Evaluate on-farm equipment availability and determine any supplemental equipment needs.
6. Ensure all overhead lines and poultry house equipment are removed or out of the way. Be sure all loose cords cables or hoses are secured so that they will not become entangled by equipment.
7. Ensure ventilation is balanced to reduce the risk of disease transmission while maintaining air quality for worker safety.
8. The composting action plan located in [Appendix J](#) can also aid in determining needs. It is intended to aid in the development of a site specific disposal plan.

### ARRANGING FOR NECESSARY EQUIPMENT AND MATERIALS

Following a Farm Assessment, the SME coordinates with the Site Manager and requests additional resources through the Incident Management Team (IMT) Logistics Branch. The resource list includes, but is not limited to:

1. skilled equipment operators and general laborers;
2. skid loader(s), pay loaders, dump trucks, mixers, rakes and scoops;
3. sawdust, litter, wood shavings, active compost, woodchips, or other carbon material (see [Appendix I](#) Compost Feedstocks for more information on potential carbon sources);
4. source of water if needed; and
5. compost thermometers (36 inch or 48 inch stem length)—(at least two per farm).

### KEY ELEMENTS FOR SUCCESSFUL COMPOSTING

The role of the SME is to ensure that these key elements are followed in the construction of compost windrows.

1. Windrows (typically 6 to 8 feet high and 12 to 15 feet wide) are constructed on an adequate and uniform base layer (10 to 15 inches thick) of a sufficiently porous and absorbent carbon material.
2. The base layer and windrow must not be compacted with equipment. Compaction can prevent essential air flow.



3. Good carcass-to-carbon contact is ensured by creating a core with a minimum 1:1 mix, by volume, of carbon with carcasses and other infected material (manure, egg shells, feed, etc.). IF THE COMPOSTING IS BEING DONE TO MANAGE CARCASSES DURING A DISEASE EVENT, DO NOT GRIND/CRUSH/MACERATE THE CARCASSES DURING CONSTRUCTION! (Slow speed mixing, however, may be done with approval of state or federal authorities.)
4. Windrows should be constructed to ensure adequate distribution of moisture throughout; the windrows are capped with carbon material (8 to 12 inches thick) to ensure that no carcasses are exposed and to minimize odor.
5. Windrow dimensions, including the base and cap, may be reduced for smaller carcasses.

### LABOR, EQUIPMENT, AND SUPPLIES

1. Skilled equipment operators and general laborers;
2. skid loader(s), pay loaders, dump trucks, rakes, and scoops;
3. sawdust, litter, wood shavings, corn stover, active compost, seed and nut hulls, woodchips, or other carbon material; and
4. compost thermometers (36" or 48" stem length).



Pay loader used for clearing the base

## Protocol for In-House Poultry Compost Windrow Construction

### TYPICAL WINDROW CONSTRUCTION PROTOCOL

Three critical elements of windrow construction are:

1. a porous base layer,
2. a uniformly mixed windrow core, and
3. an adequate cap (see Figure 1 on the following page).

These steps may be done concurrently or as separate steps.



Clearing the work area

### WINDROW BASE CONSTRUCTION

1. Before in-house composting, clear carcasses and litter from the windrow location(s) of the poultry house to create a 12 to 15 foot wide work area for construction of the windrow base(s). Distribute the material on either side of the work area. (See [Appendix C](#) for in-house variations.)
2. Using the largest loader possible, begin building the windrow base with **non-infected carbon**.
3. Building a suitable base is the first and one of the most important steps in windrow construction. The base is responsible for both improving air flow into the pile and preventing leachate from leaving the windrow.

4. The windrow base should be 12 to 15 feet wide with a depth of 8 to 12 inches. (*Note: base will compress over time.*) Base depth can vary depending on the contents of the pile core and the base material itself. Windrows with larger birds or with a lot of wet material (such as eggs) will need a deeper base than those with smaller birds and a drier core. Windrows with ground tissue and plenty of dry carbon in the core will also need less base. Base materials that do not have a mix of fines and coarser particles will likely need to be deeper to allow sufficient aeration and absorption. Windrows that contain manure, litter, or feed but no carcasses only need the minimum amount of base since these materials are less likely to generate leachate and will likely allow better natural air flow in the windrow.

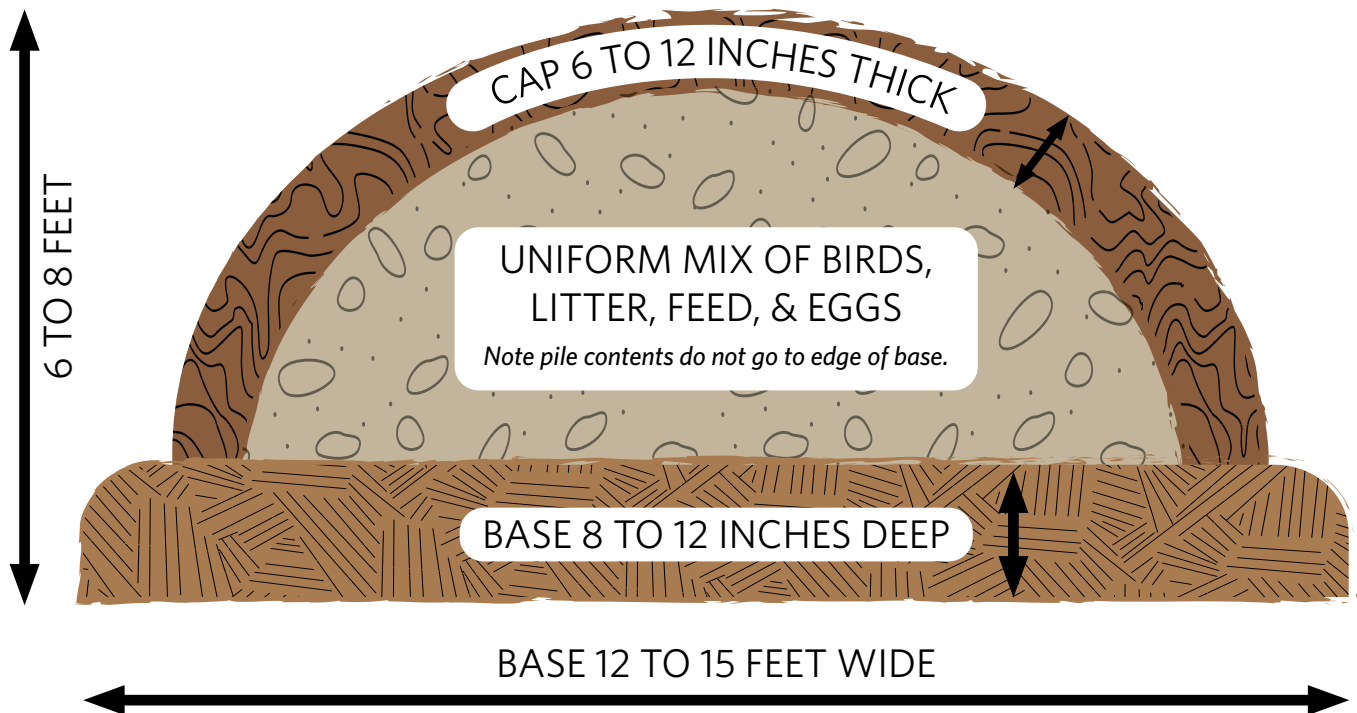

Figure 1. Completed in-house carcass windrow

5. Carbon material for the base should be porous and bulky enough to allow adequate air flow into and through the windrow. It should also have enough finer material that will absorb any leachate generated. Acceptable materials include bark mulch, chipped wood and brush, wood shavings, active compost, small grain hulls, and corn stover. Coarse woody material in excess of 2 inches should be avoided both because it will not be able to absorb leachate and it may prevent the resulting compost from being land applied as a soil amendment.
6. If only very coarse materials are available for a base, a layer of poultry litter may be used on top of the coarse material for absorbency if it is sufficiently dry and porous.
7. To maintain the base's porosity and to avoid compaction, do not drive equipment on the base.

## CONSTRUCTION OF THE CORE

1. The windrow core should consist of a uniform mix of carcasses, litter, feed, eggs and any other contaminated organic materials that must be managed. The easiest way to get a uniform mix throughout the windrow is to scoop litter and birds together in each bucket load and add it to the windrow in a manner that thoroughly mixes the contents of the bucket. If additional carbon material is needed, the material should support heat generation (i.e., composting). Suitable materials include fresh wood shavings, active compost, poultry litter, chopped straw chopped corn stover, small grain hulls or similar materials. In many instances this material may need to be blended with the existing litter and carcasses to be suitable. Any remaining feed should be blended and mixed with the carcasses and litter before windrow construction. Be sure to move infected material as little as possible.
2. If there are eggs to be disposed of, it is important to include them in the core mixture at the outset. i.e., do not leave them to be managed separately at a later time! (See discussion on managing eggs below.)
3. The mix of carcasses and litter should be added from both sides of the windrow. This allows the operators to reach the center of the windrow and to avoid compacting the base with the tires or tracks of the loader.
4. The windrow core should be constructed such that 1 foot of base material is exposed on both sides of the windrow.
5. Add water as needed so that litter and other core ingredients are damp to the touch. This is best done during the mixing process but may also be done prior to mixing depending on the circumstances. (The appropriate moisture level can easily be determined using a manual squeeze test. To do the test, take about a half cup of material in the hand and squeeze firmly. If it feels damp to the touch and forms a ball when the hand is opened, then the moisture is right. If water is released, then it is too wet but if the material feels dry and will not form a ball, it is too dry.)
6. The core should be dome-shaped with the width approximately twice the height. At this stage, the height should not exceed 6 feet. (*Note: Wide flat windrows will not aerate properly and will likely not achieve temperatures sufficient to insure pathogen inactivation.*)
7. Continue building the core until all of the litter, carcasses and other contaminated materials have been placed on the base.
8. An alternate method of using pre-compost windrows is described in [Appendix C](#).



Constructing the Core (photo by Bob Peer)

## CAPPING THE WINDROW

1. Prior to capping the windrow, remove any carcasses that are near the edge of the windrow base and include them in the center of the windrow.
2. Cap the windrow with 6 to 12 inches of a suitable non-infected carbon material. Carbon material for the cap should prevent flies from contacting carcasses, serve as an insulating blanket, and allow air to flow out of the piles. This material may be finer in texture than the base. Suitable material includes small grain hulls, sawdust, new bedding, and chipped green waste. Shavings, ground corn fodder, or similar material may also be suitable; however, experience has shown that these products can blow off the windrow and may need to be thicker to serve this purpose than other materials.

3. Ensure that the entire pile contents is uniformly covered with cap material with no carcasses exposed. (To accomplish this, it is often necessary to have a worker on the ground dedicated to observing and measuring the cap depth as it is being applied.)
4. Avoid compacting the windrow. Do not operate the loader so that the tires or tracks ride up onto the sides of the windrow while capping.
5. The completed windrow should be approximately 6 to 8 feet high and about twice as wide as the height.

### FLAGGING THE WINDROW

Windrows should be numbered and flagged by the SME at temperature monitoring locations spaced equidistantly along the length of each windrow. In order to ensure that both sides of each windrow are observed, it is recommended that half of the flags be placed on each side of a windrow. For windrows that are 500 feet or longer, a minimum of 10 flag locations are required.

For shorter windrows, the SME may choose to flag fewer locations as long as they adequately represent the full length of the windrow. In no case should fewer than three locations be marked. (See [Appendix D](#) to this section for details.)

### MANAGING EGGS

*(Note: Many poultry barns set up for egg production will have cages and may be multi-story buildings, which will not be suitable for in-house composting. This information is included here in case a layer barn happens to be suitable for in-house composting.)*

On layer operations, there are likely to be large numbers of eggs that must also be disposed of. In order to compost the eggs, they must be broken prior to mixing with the other ingredients that make up the windrow core. (Any unbroken eggs will not compost but will become 'hard-boiled' during the compost process.) The process of mixing the eggs with manure, birds and/or feed may break some of the eggs but many will likely remain whole so some method of mechanically breaking them will be needed. This will vary depending on equipment and labor available. It is recommended that the eggs be broken on a layer of dry carbon to absorb liquid and to facilitate mixing and subsequent movement to the windrow.

### PREPARATION OF LARGE CARCASSES (ON-SITE PARTICLE REDUCTION)

Operations composting larger carcasses such as tom turkeys should consider on-site particle reduction of the carcasses prior to mixing with litter, carbon materials, etc. Not only would this reduce particle size thereby speeding up the decomposition process but also prevents the problem of whole birds rolling out of the windrow during construction. If on-site particle reduction is to be done, the birds must be placed in the reduction machinery along with an approximate equal volume of carbon material such as corn stover, brush, or shavings. The resulting blend can then be mixed with other material that will go into the windrow contents and placed on the pre-made base. *(Note: On-site particle reduction may not be allowed or allowed only with specific permission from state or federal authorities in some disease events. The SME is advised to consult with the appropriate Incident Command personnel prior to recommending on-site particle reduction in a disease event.)*

On-site particle reduction equipment for this purpose must be sized appropriately for the size and volume of carcasses to be managed. Horizontal grinders have been used successfully since they can handle almost any size carcasses and allow carbon materials to be added at the same time. They can also be fed continuously so they have a high throughput rate. Vertical mixer wagons with knives have also been useful when a smaller volume needs to be managed, but their slower throughput limits their usefulness in a large event. Whatever on-site particle reduction equipment is being considered, it is important that the output is through a conveyor system that is as low to the ground as possible and does not 'shoot' the reduced product into the air but rather allowed to drop onto a bed of carbon material. Tactical operations are still being researched and developed.

## APPROVAL OF WINDROW DESIGN

An SME (or a designee) should evaluate the windrows to ensure that they have been constructed consistently with USDA current policy. The SME's (or designee's) recommendations will be documented on the Compost Approval Checklist in [Appendix G](#).

# Temperature Monitoring

---

## THERMOMETERS

During a disease outbreak, each premises should receive at least one 36-inch compost thermometer for windrow monitoring. (If available, two or more thermometers per premises would greatly reduce the time needed to do the monitoring.) Prior to being put into service, each thermometer should be calibrated according to the manufacturer's instructions. These thermometers are to remain on the premises during the outbreak. *If a thermometer is going to be moved from one farm to another, it must be disinfected thoroughly prior to leaving each premises and prior to entering another.*

## MONITORING PROTOCOL

Once the windrow construction has been approved, daily temperature monitoring can begin following the standard temperature monitoring SOP found in [Appendix D](#). Temperature monitoring must be continued at least until one of the time/temperature standards has been met (see next section). Temperature monitoring must be resumed following turning and the start of Phase 2. Temperature data should be collected on the temperature log included in [Appendix E](#) or in a comparable electronic document. The health and safety of the individual conducting the temperature monitoring should be protected by following the ammonia safety procedures outlined in [Appendix F](#).

## TIME/TEMPERATURE STANDARDS

The goal of the composting process is to create the level of beneficial microbial activity that will inactivate the pathogen in question. The easiest way to determine if that activity level has been achieved is to monitor the temperatures in the pile. In general, if the material in the pile both in the core and at the 18-inch depth has reached 131°F for three days (Disclaimer: This temperature is not specific to all diseases and should be adjusted based upon USDA recommendations) then the necessary level of activity has been achieved. At that point, if the windrow has met the other requirements established by USDA, the windrow can likely be moved into the next phase of the process. *(Note: 131°F is not for all diseases. An alternative standard may be considered and applied such as achieving 110°F for 10 days. Meeting this standard will likely require continuing to take temperatures for a longer time and may result in extending the time before a windrow may be moved into the next phase of the composting process.)* This secondary standard or any other must be approved by the State Animal Health Official.

## Turning the Windrows

---

After an SME (or designee) has reviewed and recommended that a windrow is ready to move to the next phase based on windrow design and an evaluation of the temperature data collected during the initial 14-day compost cycle (Phase 1), and the State Animal Health Official (SAHO), APHIS Official, or Incident Management Team (IMT) Official has provided their approval, the windrow is eligible for turning. Approval will be documented on the Compost Approval Checklist in [Appendix G](#). No turning is allowed before the end of the 14-day period. Turning needs to provide for the homogenization of the pile contents, base, and cap materials. Windrows need to maintain adequate porosity and structure after turning. If soft tissue is observed on the windrow surface, a 2 to 4 inch or greater carbonaceous cap should be applied. See [Appendix H](#) for turning equipment and methods.

## Release of the Compost

---

After the SME (or designee) has reviewed and recommended that a windrow be released based on windrow design and an evaluation of the temperature data collected during the second 14-day compost cycle (Phase 2), and after the SAHO, APHIS Official, or IMT Official has provided their approval the compost may be moved without restriction on the premises or may leave the premises with appropriate permits. Approval will be documented on the Compost Approval Checklist in [Appendix G](#).

## Composting Manure and Waste Feed

---

During a disease outbreak or other event, there may be a need to compost manure and waste feed without carcasses. This may be because the producer has chosen to dispose of their poultry mortalities by a method other than composting—such as onsite burial, incineration, or landfilling—or because there was more manure on the farm than could be practically composted with the poultry carcasses. In general, the compost process used for these materials is identical to the windrow construction process described above. However, because of the density of the manure and feed, it is imperative that the material be thoroughly blended with carbonaceous materials to help ensure proper porosity within the windrows. Generally, manure can be composted with a 1:1 mix of manure and carbonaceous material.

Fresh manure from a layer facility will have a high moisture content compared to older manure which may be extremely dry and hard. In either situation the moisture content may have to be adjusted. Wet manure may require additional dry material such as wood shavings to absorb some of the excess liquid prior to being placed on a porous base. Dry manure should have water added as it is being mixed with a bulky carbon source such as wood chips to achieve the right moisture content.

*(Note: Moisture content can be determined using a manual “squeeze test”. To do a squeeze test, place a small amount (about a half cup) of material in the hand and squeeze firmly. If it is damp to the touch and forms a ball when released, the moisture is about right. If it releases water when squeezed, then it is too wet. If it is not damp to the touch and will not form a ball when released then it is too dry.)*

One departure from the protocol used when composting carcasses would be the base layer under a windrow containing only manure and/or waste feed. Manure has successfully been composted on-farms for generations without a porous base if it has been blended with sufficient volume of coarse material to create a porous mixture. It should be able to self-aerate with little or no base. Likewise, if the proper moisture has been achieved in the mix, there will, unlike carcasses, be no liquid released. Because of these factors, no base should be required but may need 2-4 inch base pending density and moisture. Departure from protocols should be approved by State and other officials.

## Transitioning Ownership Between Phases

It is important, during the response to a catastrophic event that there is continuity of actions and planned actions throughout the event. Since an SME may be deployed at any point during the event there must be a smooth transition from one SME to the next person having oversight and ownership. In order to do this, there should be at least one day of overlap between the deployment times of the incoming and outgoing SMEs plus the outgoing SME should provide both a copy of the Form 214 and discuss the basis for decisions that went into it. If a written management plan is available, that should be shared as well.

## Troubleshooting

Composting is a biological process. As such, often airborne chemicals namely odors, will be emitted and sensed. Odors occur because of the decomposition of the organic matter. These odorants are volatile organic compounds generated by the biological process and are an indication of anaerobic conditions. Many of the odorants are offense to most people and have unique descriptions such as putrid, sulfurous (dimethyl disulfide) or rotten fish (dimethylamine). Often the cure for these odorants is aeration and ensure cap integrity or use of a permeable membrane

Orientation of windrows is important and should be sited appropriately at the beginning of the planning process. Windrows should be oriented to be parallel with slope and contoured such that in a storm event the runoff will not pool or be discharged into a waterway. Some sites may benefit from implementing storm water pollution prevention techniques to control or divert away from the windrows precipitation from storm events.

The table below describes some of the most common composting problems and possible solutions.

<b>Problem</b>	<b>Issue</b>	<b>Solution</b>
Excessive flies or odor	Exposed carcasses	Add additional cap material
Leachate from windrow	Mixture too wet	Add additional carbon material, mix and cap
Temperature does not reach 131°F	Mixture too dry (< 40% moisture)	Add water to pile, mix if necessary
Temperature does not reach 131°F	Mixture too wet (> 60% moisture)	Add additional carbon material, mix if necessary
Temperature drops early	Not enough oxygen	Aerate or mix pile
Temperature records indicate low temps	Improper thermometer placement	Observe temperature taking and train technician or farmer in proper technique
Leachate from windrow	Poor or no base	Re-build on proper base
Temperature does not reach 131°F	Improper pile shape/flat pile	Reshape windrow and re-cap
Temperature does not reach 131°F at pile core	Pile too large	Split into two windrows with new bases and caps
Temperature does not reach 131°F	Base is not porous	Lay out new porous base and rebuild
Temperature too high (over 165°F)	Pile too dry	Add water
Temperature too high (over 165°F)	Pile too large	Split windrow into two
Pile too wet/ poor heating	Standing water around pile	Move onto dry porous base away from standing water

## Appendix A: In-House Composting Checklist

Determine if indoor composting is a feasible option using the following checklist:

- Based on the opinion of an animal mortality composting subject matter expert (SME) are the site conditions suitable for in-house composting of the number of animals affected?
  - See [USDA Mortality Composting Protocol for Avian Influenza Infected Flocks](#) or [USDA Livestock Composting Protocol](#) (also at [go.usdatraining.com/HPAI](http://go.usdatraining.com/HPAI)).
  - Poultry houses or barns have sufficient interior space to maneuver composting equipment and construct windrows. (E.g., enough open space and ceiling height to allow loaders to construct windrows 6-8 feet high and 12 feet wide. Houses with columns, such as double-deck hen houses, can impede/restrict windrow construction.)
  - Poultry houses are located in an area that is accessible by trucks delivering carbon sources. Carbon source could be carbon material; equipment to remove all compostable material; and construct windrow.
  - Poultry houses can be secured against vandals, scavengers, and disease vectors such as wild birds.
- Perform calculation to determine required space for composting is adequate.
- If the poultry houses or barns are suitable, consider the duration of time it takes to fully compost and determine if the following issues can be overcome:
  - Personnel required to ensure proper construction, maintenance, and temperature monitoring of windrows.
  - Need for pest management (such as rodent or wild bird control).
  - Denial of use of poultry houses or barns while composting (at least 30 days).
- If so, is there a sufficient local supply of carbon source such as wood chips (1-2 pounds carbon source per pound of biomass. 1-2 is ROT; it may be more for larger animals, and/or excessive moisture)?
  - Check with local agencies and organizations to determine if stockpiles of carbon source are available (e.g., parks department NRCS, Forest Service, landscape companies and landfills). Ensure that the carbon source is free of any pests or pathogens which could threaten local species. (See [Carbon Sources for Windrow Construction](#)).
- If so, have you arranged for the necessary personnel, equipment, and supplies to be delivered to the site?
  - Mortality composting SME.
  - Composting supplies and carbon source.
  - PPE.
  - Cleaning and disinfecting (biosecurity) supplies.
  - Hand tools.
  - Heavy equipment (mid-size skid-steer loaders, tractors with bucket loaders).
  - Qualified equipment operators.
- If indoor composting is an option, see the Composting training module at [go.usdatraining.com/composting\\_module](http://go.usdatraining.com/composting_module) and implement composting. If not, continue to the next option.



## Appendix B: Methods of Estimating Carbon (Bulking Agent) Needs

---

### METHODOLOGY

Described below are three approaches to estimating the amount of additional carbonaceous materials needed to compost poultry carcasses. All three require estimating the volume of litter in a building. To do this, calculate as follows:

1. Obtain the length and width of the building.
2. Estimate the average depth of existing litter.
3. Calculate cubic feet of existing litter = length (in feet) x width (in feet) x depth (in inches) /12.
4. Convert to cubic yards: volume of litter in cubic feet/27 = cubic yards of litter.
5. Modify the estimate based on the condition of litter (volume should be reduced if there is a large volume of "cake" or of very wet litter).

Once an estimate of the existing litter has been made, an estimate of the total amount of carbonaceous material is needed. Below are three approaches for estimating the total.

### METHOD 1. WEIGHT-BASED ESTIMATE

1. Effective in-house composting must have a minimum of 1.5 pounds of carbon material (based on bulk density of 30 pounds/cubic foot material) per pound of bird (1 pound of carbon per pound of bird for the base and cover, and the remaining carbon for the mix).
2. Determine total pounds of birds:
  - Pounds of birds = number of birds x average weight in pounds.
3. Determine total pounds carbon needed:
  - Total carbon = pounds of birds (from above) x 1.5.
4. Determine pounds of litter in house:
  - Cubic feet of litter in house (see above):
    - Pounds of litter = cubic feet of litter x weight of a cubic foot of litter (average bulk density = 30 pounds; range = 25 to 35 pounds).
5. Determine amount of additional carbon needed:
  - Cubic yards of additional carbon needed = ((total pounds of carbon needed- pounds of litter in house)/(weight per cubic foot of carbon material))/(27):
    - wood chips, litter or wet sawdust = 30 pounds/cubic foot.
    - dry sawdust = 15 pounds/cubic foot.

### METHOD 2. VOLUME ESTIMATE BASED ON ANIMAL UNITS

1. Calculate the number of animal units (AUs) to be composted
  - a. Multiply the number of birds by the average weight in lbs for each different size group to get total animal weight.
  - b. Divide total animal weight by 1000 to get total AUs.

3. Calculate volume of carbon needed for compost core mixture\*:
  - Total AUs x 1.3 + 3 = volume of material needed in cubic yards.
4. Calculate volume of carbon material needed for base\*:
  - Total AUs x 1.1 + 3 = volume of material needed in cubic yards
5. Calculate volume of carbon material needed as a cap\*:
  - For a 4" cap: volume =  $0.74 \times \text{AU} + .75$
  - For a 6" cap: volume =  $1.1 \times \text{AU} + 1.1$
  - For a 8" cap: volume =  $1.47 \times \text{AU} + 1.5$
  - For a 10" cap: volume =  $1.84 \times \text{AU} + 1.85$
  - For a 12" cap: volume =  $2.21 \times \text{AU} + 2.25$
6. Calculate total volume of carbon needed in cubic yards by adding carbon for the core mixture, the base and the cap.

*\*Notes: On-farm carbon materials may be used as part of the core but cap material must be from an uncontaminated off-farm source. Base material should also be from off-farm sources if possible. If eggs are to be included, assume that 125 gallons of broken eggs is equal to 1 AU..*

### **METHOD 3. COMPUTERIZED ESTIMATOR**

1. First, use the Spartan Emergency Animal Tissue Composting Planner v1.03 to estimate the total amount of amendment needed.
2. Then use the Spartan Compost Recipe Optimizer v1.04 to estimate the amounts/proportions of amendments needed—given the availability of amendments (poultry manure, poultry litter, sawdust, bark, etc.).
3. Go to the site: [https://www.canr.msu.edu/managing\\_animal\\_mortalities/composting\\_tools](https://www.canr.msu.edu/managing_animal_mortalities/composting_tools) and then select "Composting Tools."

*Note: Listed here are several estimators. This is not an all-inclusive list of available calculators.*

## Appendix C: Variations On Typical In-House Poultry Windrow Construction Protocol

### VARIATIONS BASED ON HOUSE DESIGN

The three critical elements of **a porous base layer, a uniformly mixed windrow core, and an adequate cap**, must be maintained for successful virus inactivation regardless of variations in house design, bird size, or available carbon material.

### POLE-SUPPORTED HOUSES

- Although the support poles may limit the maneuverability of the loaders, the windrow construction protocol remains the same.
- Avoid constructing windrows against wooden support poles.
- Additional time will be required to construct windrows in this type of house due to space and structural constraints.
- Depending on the width of the house and the pole configuration, two windrows may need to be constructed instead of a single windrow in the center of the house.
- Due to structural constraints and limited maneuverability, experienced and skilled loader operators are required to minimize damage to the building and equipment.



Typical pole house design (photo by Bob Peer)



Pole house with 2 windrows (photo by Josh Payne)

### TURKEY BREEDER HOUSES

- Although designs of turkey breeder houses may vary, generally the nests and other equipment can be moved to the center and sides of the house to make space for the construction of two windrows.
- Because of limited operating space, windrows may need to be shorter (5 feet tall) and narrower (10 feet wide). This will allow the loader operator to construct the windrow core and place the cap from one side of the windrow.
- Eggs and feed should be evenly distributed onto the core of the windrow.
- Eggs must be broken with to facilitate decomposition and inactivation of virus.

### BREEDER TURKEY TOMS

- Breeder toms can weigh between 60 and 80 pounds.
- Due to their size, more carbon material may be required to maintain good carcass to carbon contact.
- Handling and placing the carcasses in the windrow may be difficult due to their size and the tendency of the carcasses to roll to the edge of the windrow. Additional labor may be necessary to appropriately position the carcasses on the windrow.
- Additional capping material may be needed to ensure that all carcasses are adequately covered.



Windrow in a Turkey Breeder House  
(photo by Gary Flory)

### BROILER-BREEDER HOUSES WITH A CENTER SCRATCH AREA

- Slats and nests must be moved outside the house after depopulation.
- Carcasses and litter in scratch area should be scooped up with a loader(s) and dumped onto the middle of the manure which was under the slats. Place equal amount of carcasses on both manure piles.
- Dump any feed onto the manure.
- Bring in carbon material to build a base 10 inches deep and 12 foot wide in the scratch area. Ensure that the base does not touch the wooden slat supports.
- Using the loader(s), mix the carcasses, manure, and feed; and place this core mix on the base, maintaining 8 to 10 inches around the edge of the base. Work from both sides as you progress down the house making sure there is enough core mix placed on the base to evenly distribute the material the length of the house.
- Using the loader(s), place 8 to 10 inches of a suitable cap material on top of the core mix, making sure that this cap does not touch the wooden slat support and that all carcasses are covered.

### BROILER-BREEDER HOUSES WITH SCRATCH AREAS ON THE SIDES

- Place the manure from under the center slats on the carcasses in the side scratch areas.
- Follow same procedure as above for building the windrow in the area under the center slats.



Typical broiler-breeder house with center scratch area  
(photo by Bob Peer)

## VARIATION OF THE STANDARD CORE CONSTRUCTION TECHNIQUE

### PRE-COMPOST WINDROWS

An alternative construction method, which increases the amount of carbon material mixed within the windrow core, is to form 2 pre-compost windrows, cap, and then form 1 final windrow. This is especially useful when dealing with large amounts of carcass material relative to litter, creating a significant C:N imbalance, or when additional carbon material will be needed to increase porosity. Forming pre-compost windrows also stabilizes the tissue and begins a heating process until a single windrow can be constructed:

- Remove litter and carcasses along sidewalls and the center of the house, forming 2 pre-compost windrows extending the length of the house.
- Cap each windrow with 8 to 12 inches of suitable carbon material.
- In the center of the house, construct a 12 to 15 feet wide base that is 10 to 15 inches deep.
- Combine both capped windrows onto the base, mixing litter, carcasses, and added carbon material.
- Cap the final windrow with 8 to 12 inches of non-infected suitable carbon material.



Pre-compost windrows



Final windrow (photo by Josh Payne)

## Appendix D: Temperature Monitoring Procedure

Monitor temperatures of the windrow daily at locations flagged by the SME. The temperature monitoring locations should be spaced equidistantly along the length of each windrow. In order to ensure that both sides of each windrow are observed, it is recommended that half of the flags are placed on each side of a windrow. For windrows that are 500 feet or longer, a minimum of 10 flag locations are required. (See Figure 2 below for two potential flag arrangements that would achieve this goal.) For shorter windrows, the SME may choose to flag fewer locations as long as they adequately represent the full length of the windrow. In no case should fewer than three locations be marked.

Take two temperature readings at each flagged location within a foot of the flag, one reading at a depth of 18 inches and another reading at a depth of 36 inches. To ensure consistent temperature monitoring to the same depth, mark the thermometer probe at 18 inches and 36 inches. Place the temperature probe  $\frac{3}{4}$  of the way up the windrow at a 45-degree angle. Ideally, temperatures should be monitored by a single individual for consistency. Temperature probes should be calibrated before being put into service and if there is any concern about the accuracy of the readings.

The goal of taking the temperatures is to gauge the activity in the most active zone (18-inch depth) and in the pile core. For windrows that are not 12 feet wide, the depth of the deeper reading should be adjusted based on the pile width. Typical windrows that are 6 feet high and 12 feet wide at the base would be monitored at the 36-inch depth. Piles that are more than a foot narrower or wider than 12 feet should be monitored at depths that are approximately  $\frac{1}{4}$  the pile width. E.g., A windrow that is 16 feet wide should be monitored at the depth of 48 inches, while a windrow that is only 8 feet wide should be monitored at 24 inches.

### Flagging Windrows for Temperature Monitoring

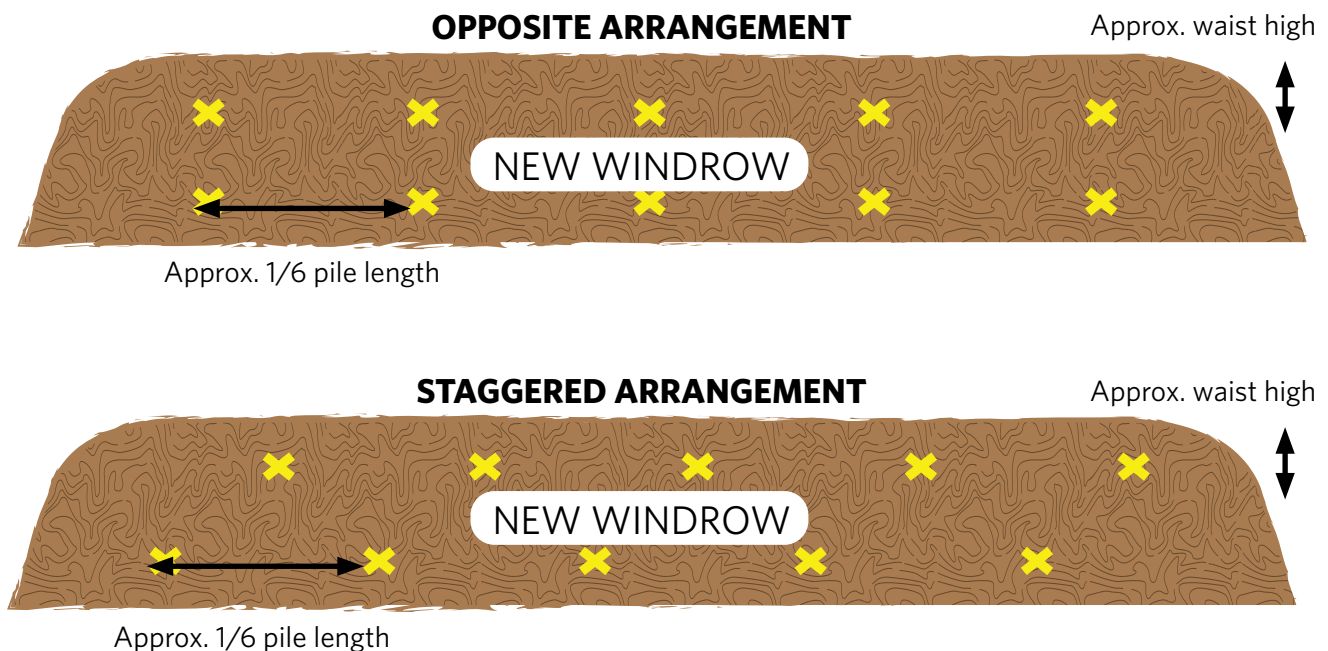

Figure 2. Recommended flag placement locations

**INSTRUCTIONS FOR TAKING WINDROW TEMPERATURES**

1. Have the farmer or farm manager turn on the fans or open the doors and curtains to all the houses containing compost piles to allow them to air out and to maximize ventilation.
2. USE THE BUDDY SYSTEM. Entering a barn with active compost or dead birds requires a two person team.
3. Place the tip of the thermometer approximately 18 inches into the compost pile about  $\frac{3}{4}$  the way up the pile at a 45-degree angle. After obtaining the 18-inch reading, then push the thermometer into the pile so that the tip is in the pile core. (See discussion above.)
4. Leave the thermometer at each depth and point for at least 60 seconds.

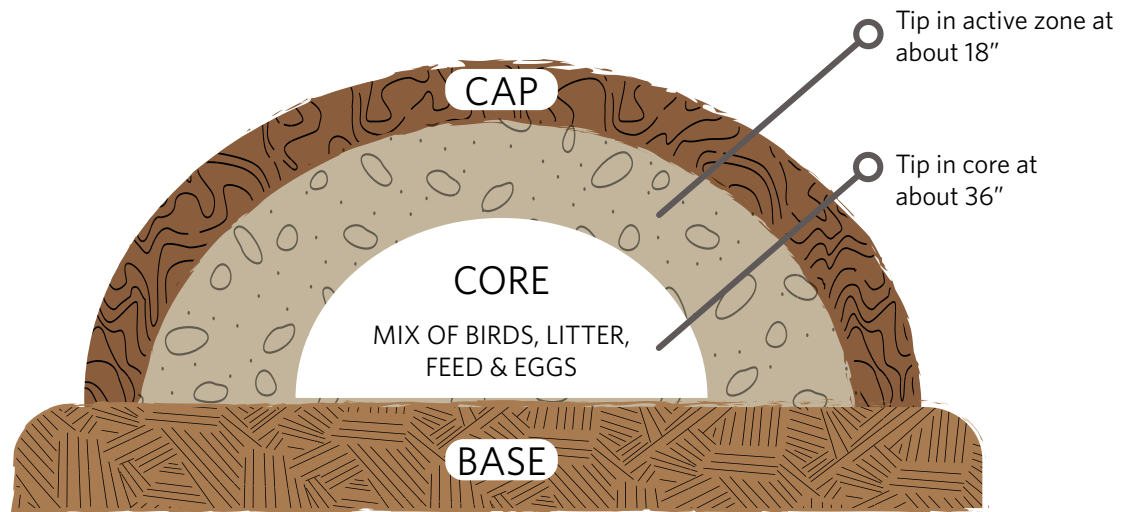

Figure 3. Thermometer placement in carcass windrow

5. Log the thermometer reading at each flag and at both depths.
6. Compare readings to previous day's readings.
7. After completing the house readings, be sure that the doors and curtains are closed.
8. Calculate the average temperatures for each pile by averaging each depth separately and note them on the Composting Temperature Log.
9. Windrows should reach average temperatures of 131°F for a minimum of three days at the 18-inch depth and at the core sometime in the first 14 days of composting. (These do not necessarily need to be consecutive or concurrent). If the temperature profiles suggest that one or both averages will not reach 131°F by day 14 the windrow should be assessed by an SME for possible corrective measures.
10. Disinfect the thermometer and return it to its protective case.
11. Keep each thermometer at the respective premises being monitored. Do not take a thermometer from one premises to another.
12. If, beginning measurements 3 days after initial windrow construction, compost temperature averages are consistently (more than 3 days) below 100°F or greater than 160°F, an SME should be consulted immediately.
13. During Phase 2, an SME should be consulted immediately if any monitoring location is consistently (more than 3 days) below 100°F or greater than 160°F.

# Appendix E: Temperature Monitoring Log Sheet

COMPOSTING TEMPERATURE LOG												
County:				Site Number:								
Street address, city, state:												
Farm Name:												
House/Windrow Number:			Date Started:			Date Finished:			Date Turned:			
Use the cells below to record the temperatures each day at 18 inches and at 36 inches.												
Date	Depth	Flag #1	Flag #2	Flag #3	Flag #4	Flag #5	Flag #6	Flag #7	Flag #8	Flag #9	Flag#10	Avg
	18"											
	36"											
	18"											
	36"											
	18"											
	36"											
	18"											
	36"											
	18"											
	36"											
	18"											
	36"											
	18"											
	36"											
	18"											
	36"											
	18"											
	36"											



## Appendix F: In-House Composting Ammonia Safety

### BACKGROUND

Ammonia is produced naturally from decomposition of organic matter, including plants, animals and animal wastes, and can become concentrated in enclosed structures. This guidance is for ammonia produced from these natural sources, NOT from compressed gas cylinders or other sources which may produce very high air concentrations.

### SIGNS OF EXPOSURE TO AMMONIA

Strong odor provides adequate early warning of its presence, but prolonged exposure can be hard to detect due to olfactory fatigue and adaptation. High concentrations can cause airway destruction resulting in respiratory distress or failure. Signs of exposure include:

- burning of the nose, throat, and respiratory tract;
- coughing; and
- skin and eye irritation.

### HOW TO REDUCE AMMONIA EXPOSURE

- Increase ventilation when possible.
- Reduce the amount of time spent in areas where levels of ammonia are high.
- Wear proper PPE, including:
  - gloves,
  - half face with goggles or a full-face respirator with at least a particulate/ammonia cartridge (green) or a multigas cartridge, and
  - cloth coveralls or disposable coveralls (Tyvek).
- If possible, measure levels of ammonia in work area with an air gas meter before entering, or know recommended exposure times based on the ammonia levels in work area.

Exposure Guidelines (NIOSH)	
Long term exposure (8 hours)	25 ppm
Short term exposure (15 minutes)	35 ppm
Short term exposure (5 minutes)	50 ppm

### IF EXPOSED TO AMMONIA

- Seek fresh air.
- Flush irritated skin or eyes with water.
- If needed, seek immediate medical attention.
- Contact your supervisor or the Safety Officer if irritation of skin, nose, throat, or respiratory tract is persistent.

## Appendix G: Compost Approval Checklists

---

The following checklists are to be used by a person who has personally reviewed the windrows on-site to submit recommendations for each phase of the composting process. Preferably this would be a composting SME but may be a designee if necessary. The checklists should be submitted to Incident Command through the farm case manager, operations chief or other appropriate Incident Command Official for each windrow being built and managed. After the Incident Commander or designee has made the final approval/disapproval, the checklists will be maintained as part of the incident record keeping.\*\*

*\*\*A composting site assessment is currently under development and will be added upon completion.*

# Initial Compost Windrow Construction Checklist

Premises ID:	Special ID:
Premises Name:	
Prem Address:	
Prem Contact (Name / Phone #):	
Date Windrows Started:	Date Windows Completed:
Windrow #:	
Who built windrow?	Contact Info:

	WINDROW DESIGN	Yes	No	N/A	Comments/Description
1	Height between 6 and 8 feet	<input type="checkbox"/>	<input type="checkbox"/>	<input type="checkbox"/>	
2	Width between 10 and 15 feet	<input type="checkbox"/>	<input type="checkbox"/>	<input type="checkbox"/>	
3	Base between 8 and 12 inches	<input type="checkbox"/>	<input type="checkbox"/>	<input type="checkbox"/>	
4	Dome shaped without significant irregularities	<input type="checkbox"/>	<input type="checkbox"/>	<input type="checkbox"/>	
5	No soft tissue visible on the surface of the windrow	<input type="checkbox"/>	<input type="checkbox"/>	<input type="checkbox"/>	
6	A minimum of 6 inches of carbon cover material	<input type="checkbox"/>	<input type="checkbox"/>	<input type="checkbox"/>	
7	Photos taken	<input type="checkbox"/>	<input type="checkbox"/>	<input type="checkbox"/>	
8	Attached sketch of flag locations and windrow dimensions	<input type="checkbox"/>	<input type="checkbox"/>	<input type="checkbox"/>	
9	Windrow core had acceptable moisture level	<input type="checkbox"/>	<input type="checkbox"/>	<input type="checkbox"/>	

## Recommendations:

- I have observed the windrows at this site and in my professional judgment they have been constructed consistent with the criteria outlined in the Mortality Composting Protocol for Avian Influenza Infected Flocks.
- I have observed the windrows at this site and in my professional judgment they have **NOT** been constructed consistent with the criteria outlined in the Mortality Composting Protocol for Avian Influenza Infected Flocks. The following corrective actions are recommended:

Signature of Composting SME: \_\_\_\_\_ Date: \_\_\_\_\_

Printed Name of Composting SME: \_\_\_\_\_

-----

The corrective actions recommended above were completed on: \_\_\_\_\_

Signature of Composting SME: \_\_\_\_\_ Date: \_\_\_\_\_

# Phase 1 Windrow Approval Checklist

**Applicability:** This checklist is to be used 14 days after windrow construction to verify that they have been constructed in accordance with the protocol and have reached temperatures necessary for virus inactivation.

Premises ID:	Special ID:
Premises Name:	
Prem Address:	
Prem Contact (Name / Phone #):	
Date Windrows Started:	Date Windows Completed:
Windrow #:	
Who built windrow?	Contact Info:

	PHASE 1 WINDROW EVALUATION – Days 1-14	Yes	No	N/A	Comments/Descriptions
1	Height between 4 and 8 feet	<input type="checkbox"/>	<input type="checkbox"/>	<input type="checkbox"/>	
2	Width between 10 and 15 feet	<input type="checkbox"/>	<input type="checkbox"/>	<input type="checkbox"/>	
3	Dome shaped without significant irregularities	<input type="checkbox"/>	<input type="checkbox"/>	<input type="checkbox"/>	
4	No soft tissue visible on the surface of the windrow	<input type="checkbox"/>	<input type="checkbox"/>	<input type="checkbox"/>	
5	A minimum of 6 inches of carbon cover material	<input type="checkbox"/>	<input type="checkbox"/>	<input type="checkbox"/>	
6	Moisture adequate	<input type="checkbox"/>	<input type="checkbox"/>	<input type="checkbox"/>	
7	Leachate present	<input type="checkbox"/>	<input type="checkbox"/>	<input type="checkbox"/>	
8	Excessive flies	<input type="checkbox"/>	<input type="checkbox"/>	<input type="checkbox"/>	
9	Vector activity observed	<input type="checkbox"/>	<input type="checkbox"/>	<input type="checkbox"/>	
10	Odor observed: VOA, putrid	<input type="checkbox"/>	<input type="checkbox"/>	<input type="checkbox"/>	
11	Temperature measured at 18 inches and 36 inches	<input type="checkbox"/>	<input type="checkbox"/>	<input type="checkbox"/>	
12	Temperatures reached 131 °F for 3 consecutive days	<input type="checkbox"/>	<input type="checkbox"/>	<input type="checkbox"/>	
13	Was there a major storm even during this period	<input type="checkbox"/>	<input type="checkbox"/>	<input type="checkbox"/>	
14	Photos taken	<input type="checkbox"/>	<input type="checkbox"/>	<input type="checkbox"/>	
15	Windrow(s) have been in place for at least 14 days after initial construction build	<input type="checkbox"/>	<input type="checkbox"/>	<input type="checkbox"/>	

**Phase 1 Recommendations of State Animal Health, APHIS, or IMT Official:**

I have reviewed the windrow compost temperature logs and other associated documentation presented by the SME. The windrows have performed in a manner demonstrated to inactivate the avian influenza virus. The 14-day initial composting cycle is complete.

I have reviewed the windrow compost temperature logs and other associated documentation presented by the SME. The windrows have **NOT** performed in a manner demonstrated to inactivate the avian influenza virus. The windrow(s) should be evaluated by a composting Subject Matter Expert to recommend corrective actions if necessary.

**Signature of State Animal Health Official**

APHIS Official, or IMT Official: \_\_\_\_\_ Date: \_\_\_\_\_

Printed name of signing official: \_\_\_\_\_

## Continuation Phase 1 Recommendations of Subject Matter Expert:

I have observed the windrows at this site and based on their construction and my review of the temperature logs and/or other associated information the windrows have performed in a manner demonstrated to inactivate the avian influenza virus. The 14-day initial composting cycle is complete.

I have observed the windrows at this site and based on their construction and my review of the temperature logs and/or other associated information the windrows have NOT performed in a manner demonstrated to inactivate the avian influenza virus. The following corrective actions below are recommended:

Signature of Composting SME: \_\_\_\_\_ Date of windrow evaluation: \_\_\_\_\_

End date of phase 1: \_\_\_\_\_

Printed name of Composting SME: \_\_\_\_\_



### Corrective Action Verification

The corrective action(s) recommended above were completed on: \_\_\_\_\_

Phase 1 corrective action(s) were verified on: \_\_\_\_\_

Signature of Composting SME: \_\_\_\_\_ Date: \_\_\_\_\_

## Phase 2 Windrow Approval Checklist

**Applicability:** This checklist is to be used 14 days after Phase 1 was completed to verify that the compost windrows may be moved without restriction on the premises or may leave the premises with appropriate permits.

Premises ID:	Special ID:
Premises Name:	
Prem Address:	
Prem Contact (Name / Phone #):	
Date Windrows Started:	Date Windows Completed:
Windrow #:	
Who built windrow?	Contact Info:

	PHASE 2 WINDROW EVALUATION – Days 14-28	Yes	No	N/A	Comments/Descriptions
1	Height between 4 and 8 feet	<input type="checkbox"/>	<input type="checkbox"/>	<input type="checkbox"/>	
2	Width between 10 and 15 feet	<input type="checkbox"/>	<input type="checkbox"/>	<input type="checkbox"/>	
3	Dome shaped without significant irregularities	<input type="checkbox"/>	<input type="checkbox"/>	<input type="checkbox"/>	
4	No soft tissue visible on the surface of the windrow	<input type="checkbox"/>	<input type="checkbox"/>	<input type="checkbox"/>	
5	A minimum of 6 inches of carbon cover material	<input type="checkbox"/>	<input type="checkbox"/>	<input type="checkbox"/>	
6	Moisture adequate	<input type="checkbox"/>	<input type="checkbox"/>	<input type="checkbox"/>	
7	Leachate present	<input type="checkbox"/>	<input type="checkbox"/>	<input type="checkbox"/>	
8	Excessive flies	<input type="checkbox"/>	<input type="checkbox"/>	<input type="checkbox"/>	
9	Vector activity observed	<input type="checkbox"/>	<input type="checkbox"/>	<input type="checkbox"/>	
10	Odor observed: VOA, putrid	<input type="checkbox"/>	<input type="checkbox"/>	<input type="checkbox"/>	
11	Temperature measured at 18 inches and 36 inches	<input type="checkbox"/>	<input type="checkbox"/>	<input type="checkbox"/>	
12	Temperatures reached 131°F for 3 consecutive days	<input type="checkbox"/>	<input type="checkbox"/>	<input type="checkbox"/>	
13	Was there a major storm event during this period	<input type="checkbox"/>	<input type="checkbox"/>	<input type="checkbox"/>	
14	Photos taken	<input type="checkbox"/>	<input type="checkbox"/>	<input type="checkbox"/>	
15	Windrow(s) have been in place at least 14 days after turning	<input type="checkbox"/>	<input type="checkbox"/>	<input type="checkbox"/>	

### Phase 2 Recommendations of State Animal Health, APHIS, or IMT Official:

I have reviewed the windrow compost temperature logs and other associated documentation presented by the SME. The windrows have performed in a manner demonstrated to inactivate the avian influenza virus. The second 14-day composting cycle (day 28) is complete. The windrows may be moved without restriction on the premises or may leave the premises with appropriate permits.

I have reviewed the windrow compost temperature logs and other associated documentation presented by the SME. The windrows have **NOT** performed in a manner demonstrated to inactivate the avian influenza virus. The windrows should be evaluated by a composting Subject Matter Expert to recommend the corrective actions if necessary.

### Signature of State Animal Health Official

APHIS Official, or IMT Official: \_\_\_\_\_ Date: \_\_\_\_\_

Printed name and organization of signing official: \_\_\_\_\_

## Continuation Phase 2 Recommendations of Subject Matter Expert:

I have observed the windrows at this site and based on their construction and my review of the temperature logs and/or other associated information, the windrows have performed in a manner demonstrated to inactivate the avian influenza virus. Recommend the windrows may be moved without restriction on the premises or may leave the premises with appropriate permits.

I have observed the windrows at this site and based on their construction and my review of the temperature logs and/or other associated information the windrows have **NOT** performed in a manner demonstrated to inactivate the avian influenza virus. The following corrective actions below are recommended:

Date of windrow evaluation: \_\_\_\_\_

Signature of Composting SME: \_\_\_\_\_ Date: \_\_\_\_\_

Windrow release Date: \_\_\_\_\_

Printed name of Composting SME: \_\_\_\_\_



### Corrective Action Verification

The corrective action(s) recommended above were complete on: \_\_\_\_\_

Phase 2 corrective action(s) were verified on and windrow can be released: \_\_\_\_\_

Signature of Composting SME: \_\_\_\_\_ Date: \_\_\_\_\_

Phase 2 was complete on: \_\_\_\_\_

Signature of Composting SME: \_\_\_\_\_ Date: \_\_\_\_\_

## Appendix H: Windrow Turning Equipment and Methods

---

Windrow turning should occur 14 days after the windrow construction is completed. There are several methods for turning windrows, both for in-house and outside windrows. The windrows constructed in-house may be turned inside the house or moved outside and reformed.

### METHODS FOR TURNING WINDROWS IN-HOUSE

Generally turning indoors will require the use of skid loaders or telehandlers with high-capacity buckets to turn windrows. Other types of equipment such as farm tractors with buckets may be used but are less maneuverable in confined spaces. Material in the existing windrow needs to be lifted and dumped in a manner that provides maximum mixing and aeration while forming a new windrow.

The strategy for efficiently turning in a building will depend on the space available, the number of existing windrows in that space, the type of equipment to be used and operator skills and preferences. It is recommended that the SME consult with the lead equipment operator on the most effective strategy for turning in each specific situation. Some common turning strategies are illustrated below.

### PRIOR TO TURNING

Before discussing turning strategies, the SME must make sure the operators know the requirements for completing Phase 2 of the composting process. Specifically, make sure that they know the following:

- No new base is needed unless windrow is unusually wet
- The base must be 10ft to 15ft wide
- The Pile height at the end of the process must be 4 feet to less than 8 feet (which means that newly constructed height will need to be at least 5 feet high due to pile shrinkage)
- The pile must be dome-shaped with the height roughly half the pile width (i.e., no wide flat windrows).
- There must be no exposed tissue.
- A cap (6 inches) may be needed if there is a significant amount of exposed tissue.



Pre-compost windrows (photo by Josh Payne)



COMMON TURNING STRATEGIES:

**Turning in a Tight Space** (one skid steer)

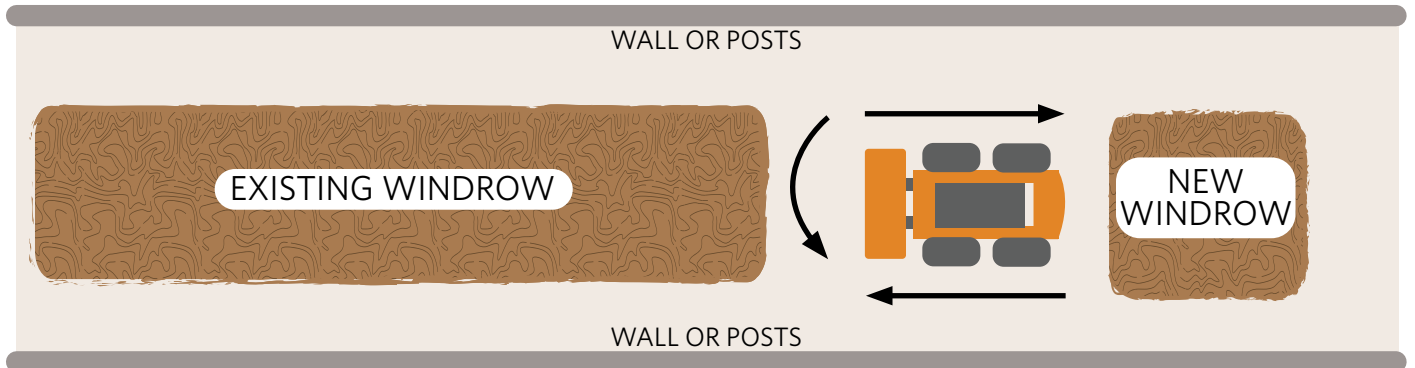

**Turning in Open Span Single Windrow**

(two or four alternating skid steers or tractors pushing *and lifting* to move material)

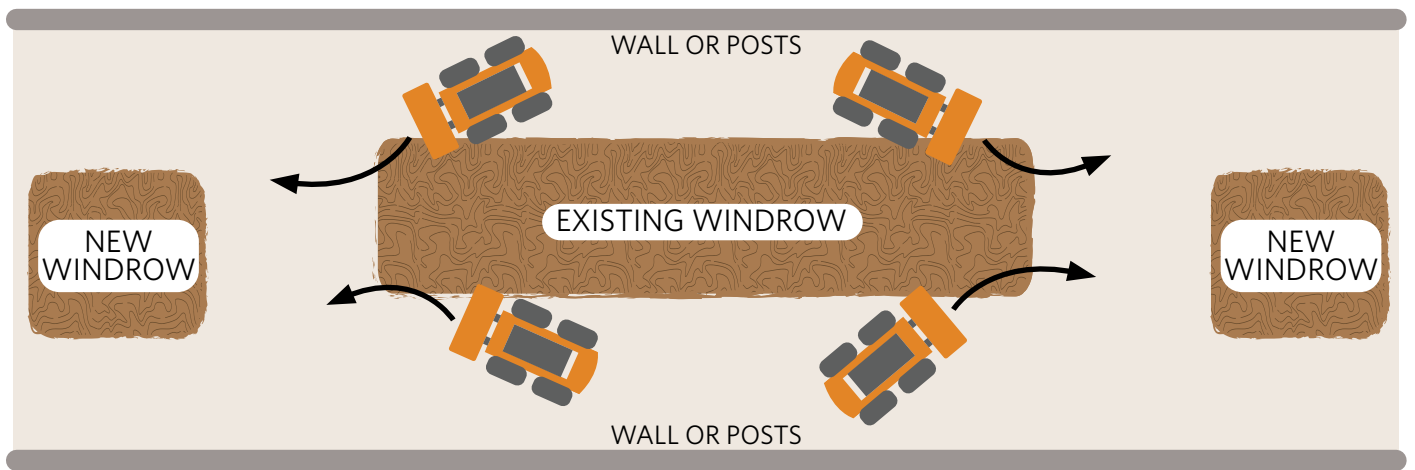

**Turning in Open Span Single Windrow**

(two or four alternating skid steers or tractors pushing *and lifting* to move material)

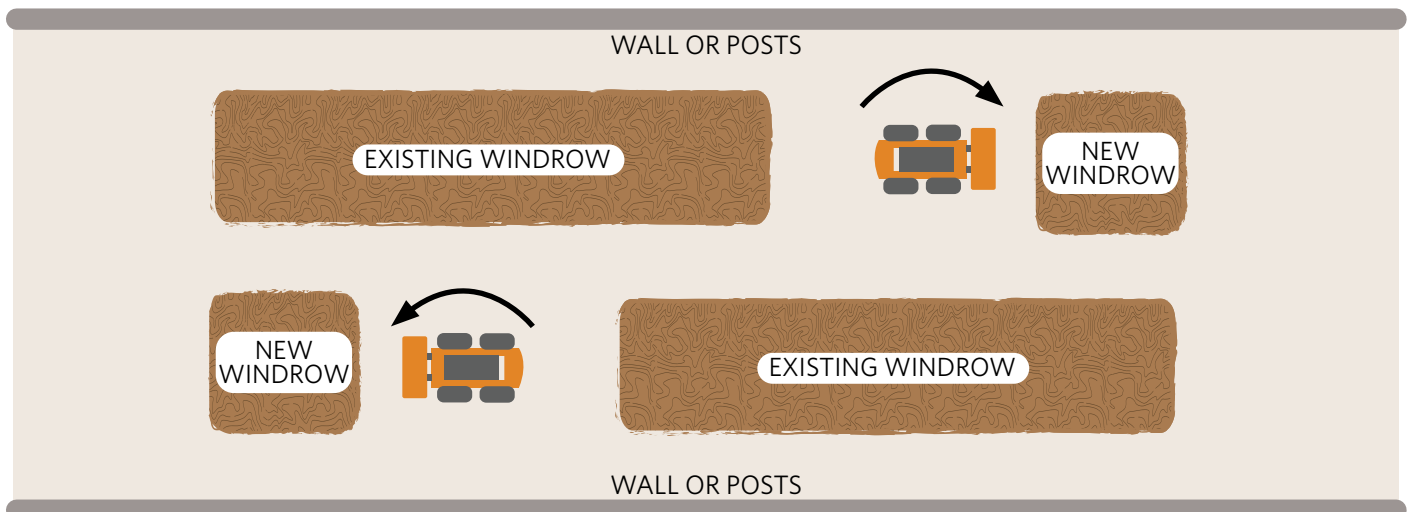

LESS COMMON STRATEGIES THAT COULD ALSO BE USED:

**Turning in Open Span** (four skid steers)

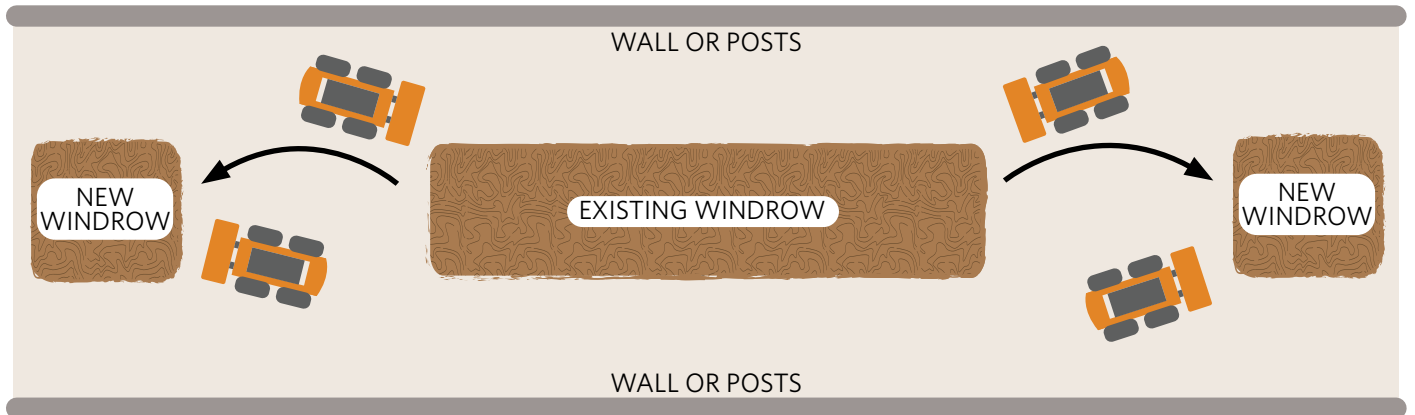

**Turning in Space for Two Windrows**  
(two skid steers or tractors)

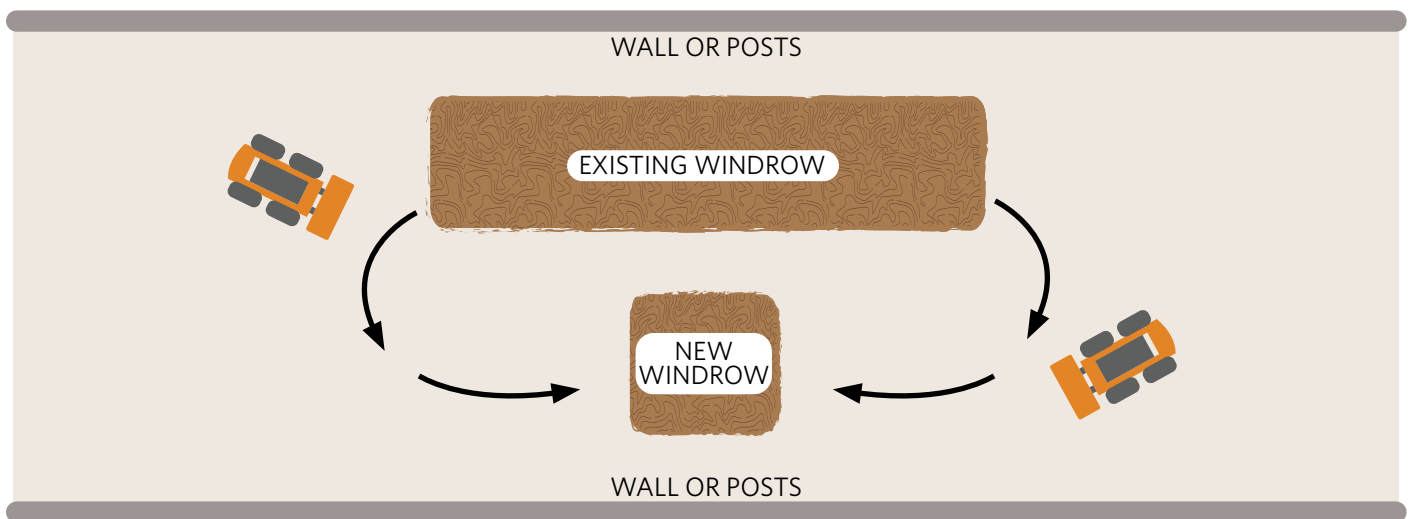

# Appendix I: Compost Feedstocks

## CARBON SOURCES FOR WINDROW CONSTRUCTION

*Note: These procedures may be revised as the situation develops; this is a list of generally acceptable carbon sources for windrow composting of HPAI-related mortalities. The carbon source resource needs for the premises (i.e., quantity and type) should be determined by a compost SME and will depend on site-specific (typically poultry house-specific) conditions and circumstances.*

### SUITABLE CARBON SOURCES

- Wood chips about 2" or less in size
- Wood shavings
- Yard/brush trimmings 2" or less in size
- Partially composted leaf and yard waste (still hot)
- Sawdust (not used alone)
- Chopped hay/straw
- Chopped corn stover
- Oat/sunflower hulls
- Ground pallets (2" or less) if fasteners have been removed
- Other material listed in APHIS *Composting Protocol* or as recommended by APHIS-recognized SME and approved for use on agricultural land by the state

Mulch from yard trimmings/waste



Wood chips



Chopped corn stover



Oat hulls



### NOT SUITABLE WITHIN A CARBON SOURCE

- Rocks
- Glass
- Plastic
- Large logs/branches
- Grass clippings >15%
- Ground construction & demolition debris (CDD)
- Regulated pests (emerald ash borer, etc.)
- Rubber
- Metal/baling wire
- Chemicals
- Concrete
- Painted/pressure treated wood
- Soil/sand >15% by volume
- Carbon source with free liquid or excessive leachate

Wood chips with rocks/gravel



Construction demolition debris



Mixed wood with logs/large lumber pieces



## TERMINOLOGY OF CARBON

*Specifying types of carbon can be complicated because there is not a universal standard. To aid in procurement the following is offered to aid in description and origin of carbon materials.*

Successful composting utilizes two types of carbon materials:

- The **base** is composed of coarse material in order to allow air flow.
- The **cap** is composed of a aggregate of coarse and fine material to provide the insulating cap for vectors, odors, and precipitation control.

Universally the “brown” materials are high in carbon content and the “green” materials are higher in nitrogen.

### FINER MATERIALS

- Fine and coarse sawdust
  - Can be green or kiln dried
- Shavings or flakes - may be of a consistent size or may include sawdust
  - Medium and fine shavings

### COARSER MATERIALS

- Classified by type of material
  - Bark mulch
  - Hardwood mulch/chips
- Classified by the size of the largest particles
  - 2 inches and under
  - Single ground
  - Double ground
- Classified by the consistency of the particle sizes
  - Screened mulch
  - Mulch with fines and coarse material
- Classified by the source
  - Ground yard waste
  - Ground storm debris
  - Ground tree trimming material (mixed sizes, hardwood, softwood and greens (leaves))
  - Ground pallets

# Characteristics of Raw Materials<sup>1</sup>

Material	Type of value	% N (dry weight)	C:N ratio (weight to weight)	Moisture content % (wet weight)	Bulk density (lbs per cubic yard)
<b>CROP RESIDUES AND FRUIT/VEGETABLE-PROCESSING WASTE</b>					
Apple filter cake	Typical	1.2	13	60	1,197
Apple filter cake	Typical	1.2	13	60	1,197
Apple pomace	Typical	1.1	48	88	1,559
Apple-processing sludge	Typical	2.8	7	59	1,411
Cocoa shells	Typical	2.3	22	8	798
Coffee grounds	Typical	—	20	—	—
Corn cobs	Range Average	0.4-0.8 0.6	56-123 98	9-18 15	— 557
Corn stalks	Typical	0.6-0.8	60-73 <sup>a</sup>	12	32
Cottonseed meal	Typical	7.7	7	—	—
Cranberry filter cake	Typical	2.8	31	50	1,021
(with rice hulls)	Typical	1.2	42	71	1,298
Cranberry plant (stems, leaves)	Typical	0.9	61	61	—
Cull potatoes	Typical	—	18	78	1,540
Fruit wastes	Range Average	0.9-2.6 1.4	20-49 40	62-88 80	— —
Olive husks	Typical	1.2-1.5	30-35	8-10	—
Potato-processing sludge	Typical	—	28	75	1,570
Potato tops	Typical	1.5	25	—	—
Rice hulls	Range Average	0-0.4 0.3	113-1120 121	7-12 14	185-219 202
Soybean meal	Typical	7.2-7.6	4-6	—	—
Tomato-processing waste	Typical	4.5	11 <sup>a</sup>	62	—
Vegetable produce	Typical	2.7	19	87	1,585
Vegetable wastes	Typical	2.5-4	11-13	—	—
<b>FISH AND MEAT PROCESSING</b>					
Blood wastes (slaughterhouse waste and dried blood)	Typical	13-14	3-3.5	10-78	—
Crab and lobster wastes	Range Average	4.6-8.2 6.1	4.0-5.4 4.9	35-61 47	— 240
Fish-breeding crumbs	Typical	2.0	28	10	—
Fish-processing sludge	Typical	6.8	5.2	94	—
Fish wastes (gurry, racks, and so on)	Range Average	6.5-14.2 10.6	2.6-5.0 3.6	50-81 76	— —
Mixed slaughterhouse waste	Typical	7-10	2-4	—	—
Mussel wastes	Typical	3.6	2.2	63	—
Poultry carcasses	Typical	2.4 <sup>b</sup>	5	65	—
Paunch manure	Typical	1.8	20-30	80-85	1,460
Shrimp wastes	Typical	9.5	3.4	78	—

Material	Type of value	% N (dry weight)	C:N ratio (weight to weight)	Moisture content % (wet weight)	Bulk density (lbs per cubic yard)
----------	---------------	---------------------	---------------------------------	------------------------------------	--------------------------------------

**MANURES**

Broiler litter	Range	1.6-3.9	12-15 <sup>a</sup>	22-46	756-1,026
	Average	2.7	14 <sup>a</sup>	37	864
Cattle	Range	1.5-4.2	11-30	67-87	1,323-1,674
	Average	2.4	19	81	1,458
Dairy tie stall	Typical	2.7	18	79	—
Dairy free stall	Typical	3.7	13	83	—
Horse-general	Range	1.4-2.3	22-50	59-79	1,215-1,620
	Average	1.6	30	72	1,379
Horse-race track	Range	0.8-1.7	29-56	52-67	—
	Average	1.2	41	63	—
Laying hens	Range	4-10	3-10	62-75	1,377-1,620
	Average	8.0	6	69	1,479
Sheep	Range	1.3-3.9	13-20	60-75	—
	Average	2.7	16	69	—
Swine	Range	1.9-4.3	9-19	65-91	—
	Average	3.1	14	80	—
Turkey litter	Average	2.6	16 a	26	783

**MUNICIPAL WASTES**

Garbage (food waste)	Typical	1.9-2.9	14-16	69	—
Night soil	Typical	5.5-6.5	6-10	—	—
Paper from domestic refuse	Typical	0.2-0.25	127-178	18-20	—
Pharmaceutical wastes	Typical	2.6	19	—	—
Refuse (mixed food, paper, etc.)	Typical	0.6-1.3	34-80	—	—
Sewage sludge	Range	2-6.9	5-16	72-84	1,075-1,750
Activated sludge	Typical	5.6	6	—	—
Digested sludge	Typical	1.9	16	—	—

**STRAW, HAY, SILAGE**

Corn silage	Typical	1.2-1.4	38-43 <sup>a</sup>	65-68	—
Hay-general	Range	0.7-3.6	15-32	8-10	—
	Average	2.10	—	—	—
Hay-legume	Range	1.8-3.6	15-19	—	—
	Average	2.5	16	—	—
Hay-non-legume	Range	0.7-2.5	—	—	—
	Average	1.3	32	—	—
Straw-general	Range	0.3-1.1	48-150	4-27	58-378
	Average	0.7	80	12	227
Straw-oat	Range	0.6-1.1	48-98	—	—
	Average	0.9	60	—	—
Straw-wheat	Range	0.3-0.5	100-150	—	—
	Average	0.4	127	—	—

Material	Type of value	% N (dry weight)	C:N ratio (weight to weight)	Moisture content % (wet weight)	Bulk density (lbs per cubic yard)
<b>WOOD AND PAPER</b>					
Bark-hardwoods	Range Average	0.10-0.41 0.241	116-436 223	— —	— —
Bark-softwoods	Range Average	0.04-0.39 0.14	131-1,285 496	— —	— —
Corrugated cardboard	Typical	0.10	563	8	259
Lumbermill waste	Typical	0.13	170	—	—
Newsprint	Typical	0.06-0.14	398-852	3-8	195-242
Paper fiber sludge	Typical	—	250	66	1140
Paper mill sludge	Typical	0.56	54	81	—
Paper pulp	Typical	0.59	90	82	1403
Sawdust	Range Average	0.06-0.8 0.24	200-750 442	19-65 39	350-450 410
Telephone books	Typical	0.7	772	6	250
Wood chips	Typical	—	—	—	445-620
Wood-hardwoods (chips, shavings, and so on)	Range Average	0.06-0.11 0.09	451-819 560	— —	— —
Wood-softwoods (chips, shavings, and so on)	Range Average	0.04-0.23 0.09	212-1,313 641	— —	— —
<b>YARD WASTES AND OTHER VEGETATION</b>					
Grass clippings	Range Average	2.0-6.0 3.4	9-25 17	— 82	— —
Loose	Typical	—	—	—	300-400
Compacted	Typical	—	—	—	500-800
Leaves	Range Average	0.5-1.3 0.9	40-80 54	— 38	— —
Loose and dry	Typical	—	—	—	100-300
Compacted and moist	Typical	—	—	—	400-500
Seaweed	Range Average	1.2-3.0 1.9	5-27 17	— 53	— —
Shrub trimmings	Typical	1.0	53	15	429
Tree trimmings	Typical	3.1	16	70	1,296
Water hyacinth-fresh	Typical	—	20-30	93	405

1 Reprinted with permission from the Cornell Waste Management Institute.

a Estimated from ash or volatile solids data.

b Mostly organic nitrogen.

# Appendix J: Compost Action Plan

Date of confirmation: \_\_\_\_\_ Farm Premise ID: \_\_\_\_\_ Animal Species: \_\_\_\_\_

Farm Address: \_\_\_\_\_

Points of Contact: Case Manager: Name; \_\_\_\_\_ Contact Info; \_\_\_\_\_

Premise staff: Name; \_\_\_\_\_ Contact Info; \_\_\_\_\_

Compost SME: Name; \_\_\_\_\_ Contact Info; \_\_\_\_\_

## Windrow construction:

Estimated volume of material (birds, litter, manure, feed) to be composted: \_\_\_\_\_ cubic yards

- Additional carbon material **needed for the core**: Coarse: \_\_\_\_\_ cu. yds. Fine: \_\_\_\_\_ cu. yds.
- Windrow dimensions: width \_\_\_\_\_ feet x height \_\_\_\_\_ feet
  - Consider turning options:
- Coarse carbon for base material: Depth: \_\_\_\_\_ inches Volume: \_\_\_\_\_ cubic yards
- Fine carbon Cap material: Depth: \_\_\_\_\_ inches Volume: \_\_\_\_\_ cubic yards
- Total Length of Windrow Required: \_\_\_\_\_ feet
- Average Windrow Length: \_\_\_\_\_ feet
- Will all this material fit into the houses or land space available: Yes: \_\_\_\_\_ No: \_\_\_\_\_

Notes: \_\_\_\_\_  
 \_\_\_\_\_  
 \_\_\_\_\_

**Carbon:** Estimated volume of all carbon material required: Coarse: \_\_\_\_\_ cu. yds. Fine: \_\_\_\_\_ cu. yds.

- Source: \_\_\_\_\_ Contact information: \_\_\_\_\_
- Coarse Carbon Available: \_\_\_\_\_ cubic yards Fine Carbon Available: \_\_\_\_\_ cubic yards
- Visual inspection of carbon at source: Yes: \_\_\_\_\_ No: \_\_\_\_\_
- Visual inspection of carbon upon arrival: Yes: \_\_\_\_\_ No: \_\_\_\_\_

## Outside Windrow spacing/layout area required: Consider turning options

- Single windrow: \_\_\_\_\_ acres Notes: \_\_\_\_\_
  - Alley width: \_\_\_\_\_ ft
- Toe to Toe (double): \_\_\_\_\_ acres
  - Alley width: \_\_\_\_\_ ft
- Toe to Toe (continuous): \_\_\_\_\_ acres

## Delivery Location:

- In hot zone: \_\_\_\_\_ Outside the hot zone: \_\_\_\_\_ On edge of hot zone: (no C&D required) \_\_\_\_\_
- Loads per day coarse: \_\_\_\_\_ Loads per day fine: \_\_\_\_\_

Notes: \_\_\_\_\_  
 \_\_\_\_\_  
 \_\_\_\_\_



**Estimated Water Require:**

Total Gallons: \_\_\_\_\_ Daily: \_\_\_\_\_ gallons

Source: \_\_\_\_\_ Application method/rate: \_\_\_\_\_

Estimated Rate of Application: \_\_\_\_\_ gallons/hour

**Notes:** \_\_\_\_\_  
 \_\_\_\_\_  
 \_\_\_\_\_

**Aerial Maps:** draw on map the following features

- Premise
  - C& D line
  - Truck traffic pattern
  - Crew operations/staging
  - Access points
- Outside compost operation
  - Windrow location
  - Carbon stockpile
  - Environmental features
  - Setbacks from sensitive areas

**Notes:** \_\_\_\_\_  
 \_\_\_\_\_  
 \_\_\_\_\_

**Equipment Recommendations:** work with contractor or farm staff to determine the type and number of each piece of equipment.

- Skid loaders: \_\_\_\_\_
- Skid loaders with tipper buckets: \_\_\_\_\_
- Side dump vehicles: \_\_\_\_\_
- Mix wagons: \_\_\_\_\_
- Front-end loader: \_\_\_\_\_
- Telehandler: \_\_\_\_\_
- Compost turning: \_\_\_\_\_
- Compost turner: \_\_\_\_\_
  - Over the row: \_\_\_\_\_
  - Tag along straddle: \_\_\_\_\_
- Other Equipment: \_\_\_\_\_

**Notes:** \_\_\_\_\_  
 \_\_\_\_\_  
 \_\_\_\_\_

**Pile Construction:**

- Crew training needed: Yes: \_\_\_\_\_ No: \_\_\_\_\_
- SME oversight needed: Yes : \_\_\_\_\_ No: \_\_\_\_\_
- If "Yes" then estimate the number of days required for SME oversight: \_\_\_\_\_ days.

**Notes:** \_\_\_\_\_  
 \_\_\_\_\_  
 \_\_\_\_\_

**Daily windrow monitoring:**

- Temperature data collection:
  - Who will be responsible: \_\_\_\_\_
- Temperature monitoring training:
  - Who is to be trained: \_\_\_\_\_
  - Who will conduct the training? \_\_\_\_\_

Notes: \_\_\_\_\_  
\_\_\_\_\_  
\_\_\_\_\_

Turning:

- Method: \_\_\_\_\_
- Who: \_\_\_\_\_

Notes: \_\_\_\_\_  
\_\_\_\_\_  
\_\_\_\_\_

**Compost Action plan development team:**

Farm Representative: \_\_\_\_\_ Case Manager: \_\_\_\_\_  
Composting SME: \_\_\_\_\_ Site Manager: \_\_\_\_\_  
Disposal Coordinator (State/Federal): \_\_\_\_\_

**Place corrective actions, other disposal options, lessons learned here:**

# Appendix K: Composting SME Daily Activity Log - ICS-214-CS

*Use a separate form for each premises*

<b>1. Disease:</b> Incident Site:  <b>2. Premises:</b>		<b>3. Operational Period:</b>	
		4 Date From:	5. Time From: Click here to enter text.
		6. Date To:	7. Time To: Click here to enter text.
8. SME Name:	9. ICS Location:	10. Email and Cell Phone Number:	
<b>11. Resources Assigned:</b>			
	<b>Name:</b>	<b>Email and Cell Phone Number</b>	
<b>Contractor on-site</b>	Click here to enter text.	Click here to enter text.	
<b>Federal/State on-site</b>	Click here to enter text.	Click here to enter text.	
<b>12. Activity Log:</b>			
<b>Barn/House #</b>	<b>Windrow #</b>	<b>Activities Performed Today</b>	
Click here to enter text.	Click here to enter text.	Click here to enter text.	
Click here to enter text.	Click here to enter text.	Click here to enter text.	
Click here to enter text.	Click here to enter text.	Click here to enter text.	
Click here to enter text.	Click here to enter text.	Click here to enter text.	
Click here to enter text.	Click here to enter text.	Click here to enter text.	
Click here to enter text.	Click here to enter text.	Click here to enter text.	
<b>Barn/House #</b>	<b>Windrow #</b>	<b>Activities Planned for Tomorrow</b>	
All barns	Click here to enter text.	Click here to enter text.	
Click here to enter text.	Click here to enter text.	Click here to enter text.	
Click here to enter text.	Click here to enter text.	Click here to enter text.	

**ATTACH SKETCH OF WINDROW LOCATIONS AND NUMBERS, PHOTOS:**

**NOTES:**

Prepared by: Click here to enter text.      Position/Title: Click here to enter text.

X

Inspector/Compost SME

This document may contain Personally Identifiable Information (PII) which is "Sensitive Security Information - Disseminate on a Need-to-Know Basis Only." You are responsible to safeguard and protect this information from unauthorized access or disclosure.

Animals Type:	Number of Animals:	Average weight:				
Number of Barns:						
Composting location: <input type="checkbox"/> In-House Composting <input type="checkbox"/> Outside Windrow Composting						
Weather: _____ °F      Conditions: _____						
<b>OPERATIONAL Opportunities and Challenges:</b>						
Rate each category	5	4	3	2	1	NA
	Great		okay		Needs	
	(No action required)		need to watch		action	
<b>Planning:</b>						
• Compost Disposal Plan:	<input type="checkbox"/>	<input type="checkbox"/>	<input type="checkbox"/>	<input type="checkbox"/>	<input type="checkbox"/>	<input type="checkbox"/> Notes: _____
• Contractor Selection:	<input type="checkbox"/>	<input type="checkbox"/>	<input type="checkbox"/>	<input type="checkbox"/>	<input type="checkbox"/>	<input type="checkbox"/> Notes: _____
• Carbon Sourcing:	<input type="checkbox"/>	<input type="checkbox"/>	<input type="checkbox"/>	<input type="checkbox"/>	<input type="checkbox"/>	<input type="checkbox"/> Notes: _____
<b>Barn /site issues:</b>						
• Outside site issues:	<input type="checkbox"/>	<input type="checkbox"/>	<input type="checkbox"/>	<input type="checkbox"/>	<input type="checkbox"/>	<input type="checkbox"/> Notes: _____
• Environmental issues:	<input type="checkbox"/>	<input type="checkbox"/>	<input type="checkbox"/>	<input type="checkbox"/>	<input type="checkbox"/>	<input type="checkbox"/> Notes: _____
• Structural issues:	<input type="checkbox"/>	<input type="checkbox"/>	<input type="checkbox"/>	<input type="checkbox"/>	<input type="checkbox"/>	<input type="checkbox"/> Notes: _____
<b>Composting Operations:</b>						
• Recipe development:	<input type="checkbox"/>	<input type="checkbox"/>	<input type="checkbox"/>	<input type="checkbox"/>	<input type="checkbox"/>	<input type="checkbox"/> Notes: _____
• Contractor Concerns:	<input type="checkbox"/>	<input type="checkbox"/>	<input type="checkbox"/>	<input type="checkbox"/>	<input type="checkbox"/>	<input type="checkbox"/> Notes: _____
• Equipment issues:	<input type="checkbox"/>	<input type="checkbox"/>	<input type="checkbox"/>	<input type="checkbox"/>	<input type="checkbox"/>	<input type="checkbox"/> Notes: _____
• Personnel issues:	<input type="checkbox"/>	<input type="checkbox"/>	<input type="checkbox"/>	<input type="checkbox"/>	<input type="checkbox"/>	<input type="checkbox"/> Notes: _____
<b>Windrows Construction:</b>						
• Base Carbon issues:	<input type="checkbox"/>	<input type="checkbox"/>	<input type="checkbox"/>	<input type="checkbox"/>	<input type="checkbox"/>	<input type="checkbox"/> Notes: _____
• Mixing/Consistency:	<input type="checkbox"/>	<input type="checkbox"/>	<input type="checkbox"/>	<input type="checkbox"/>	<input type="checkbox"/>	<input type="checkbox"/> Notes: _____
• Moisture issues:	<input type="checkbox"/>	<input type="checkbox"/>	<input type="checkbox"/>	<input type="checkbox"/>	<input type="checkbox"/>	<input type="checkbox"/> Notes: _____
• Capping Material:	<input type="checkbox"/>	<input type="checkbox"/>	<input type="checkbox"/>	<input type="checkbox"/>	<input type="checkbox"/>	<input type="checkbox"/> Notes: _____
• Pile Structure	<input type="checkbox"/>	<input type="checkbox"/>	<input type="checkbox"/>	<input type="checkbox"/>	<input type="checkbox"/>	<input type="checkbox"/> Notes: _____
• Temperature issues:	<input type="checkbox"/>	<input type="checkbox"/>	<input type="checkbox"/>	<input type="checkbox"/>	<input type="checkbox"/>	<input type="checkbox"/> Notes: _____
• Vector Control	<input type="checkbox"/>	<input type="checkbox"/>	<input type="checkbox"/>	<input type="checkbox"/>	<input type="checkbox"/>	<input type="checkbox"/> Notes: _____
• Hot spots, fire concerns:	<input type="checkbox"/>	<input type="checkbox"/>	<input type="checkbox"/>	<input type="checkbox"/>	<input type="checkbox"/>	<input type="checkbox"/> Notes: _____
<b>Other issues:</b>						
• USDA compliance:	<input type="checkbox"/>	<input type="checkbox"/>	<input type="checkbox"/>	<input type="checkbox"/>	<input type="checkbox"/>	<input type="checkbox"/> Notes: _____
• Biosecurity:	<input type="checkbox"/>	<input type="checkbox"/>	<input type="checkbox"/>	<input type="checkbox"/>	<input type="checkbox"/>	<input type="checkbox"/> Notes: _____
• Interpersonal relations:	<input type="checkbox"/>	<input type="checkbox"/>	<input type="checkbox"/>	<input type="checkbox"/>	<input type="checkbox"/>	<input type="checkbox"/> Notes: _____
• SME health/welfare:	<input type="checkbox"/>	<input type="checkbox"/>	<input type="checkbox"/>	<input type="checkbox"/>	<input type="checkbox"/>	<input type="checkbox"/> Notes: _____
• Other:	_____					<input type="checkbox"/> Notes: _____
Comments/Notes: _____						
_____						
ICS-214-CS						

This document may contain Personally Identifiable Information (PII) which is "Sensitive Security Information - Disseminate on a Need-to-Know Basis Only." You are responsible to safeguard and protect this information from unauthorized access or disclosure.

## Appendix L: 214 Daily Activity Log Report Guidance Document

---

The ICS-214-CS Daily Activity Log (or 214) is a critical communication document used by multiple government agencies during an animal disease outbreak response. It is also a legal, historical, and managerial document, where the information is critical. Therefore, it needs to be concise, accurate, and timely. This guidance document will focus on how the 214 should be completed, and on what information needs to be included.

### THE REPORT NEEDS TO ADDRESS THE 5 W'S: WHAT, WHO, WHEN, WHERE, AND WHY

#### What

- What did you observe? (Focus on the facts, note your observations)
- What was discussed?
- What decisions were made?
- What are the action items?
  - If corrective action is required, list the steps, resources, and timing.
  - Who is responsible for acquiring the resources?
- What are your concerns about people, process, performance, problems, etc.?

#### Who

- Who did you speak to?
- Who is following up on the action items?
- Who have you included in the decision-making process?

#### When

- When was the discussion?
- When will the action items be completed and by whom?
- When (best estimate) will the different phases be completed?

#### Where

- Be as specific as possible, e.g., barn #(s), windrow #s, etc. for each action item.
- Use a quick sketch if necessary to help document the “where” for clarity.

#### Why

- Why was this action required, a brief explanation for corrective actions.

### THINGS TO CONSIDER AND INCLUDE WHEN WRITING A 214 DAILY ACTIVITY LOG REPORT

#### The Composting Plan

- Are you planning to prepare a composting plan?
- Has that already been done and by whom?
- Do you have access to that plan for review and guidance going forward?

- Who is doing the actual windrow construction? (Contractor/farm staff?)
- Is there a known source of carbon? Has it been evaluated and approved?
- Are inventories of animals and all other on-farm compostable materials accurate?
- Ask about all feed storages, manure storages, commodity barns, food tanks, and cold storage onsite.

### **Barn/Site Issues**

- Are there outside site restrictions, limitations, etc.?
- Are there site or field conditions that need to be addressed?
- Are there access opportunities and challenges?
- Are there environmental issues that need attention?
- Are there barn concerns, structural, heights, age, floors, etc.?

### **Composting operations**

- Are you confident the recipe being used will produce the desired temperature performance?
- Is the flow of carbon material acceptable, consistent, coarse or fine enough, slow in being delivered?
- Are carbon sources changing? Describe changes in type, quality, delivery, etc.
- Make notations for resulting plan changes/amendments.
- Is there sufficient equipment available? Do they need more or different equipment?
- Are they proficient? And are they receptive to your instructions?
- Is staffing sufficient? Can they keep up with the schedule?

### **Windrow Construction**

- Are the bases thick and wide enough, and consistent?
- Are they mixing or layering materials thoroughly?
- Are there moisture issues: too wet, too dry, inconsistent?
- Is the capping material appropriate? Too coarse, too fine, depth of cap?
- Are there environmental concerns with cap material: wind, contamination, etc.?
- Is there adequate vector control: flies, rodents, birds, local domestic pets, etc.?
- Who is taking windrow temperatures and recording them?
- Are there issues with temperature gathering, documentation, analysis, concerns?
- Are there concerns about spontaneous combustion and possible fire danger?

### **Other issues**

- Are they following USDA protocols for windrow construction?
- What is the interaction like with producer, integrator, contractor, case manager, veterinarian in charge, and other response personnel?
- Are you comfortable, confident, and in control of the composting process in general?
- Are you comfortable, confident, and in control of the composting process for this site?
- Is your work under inappropriate pressure from parties outside your Chain of Command in the response framework?
- Are you confident in the information being provided to you by other parties?
- Are there any biosecurity, safety, regulatory issues that need attention not covered above?
- Are there issues that need to be addressed outside of your scope of work and responsibility?

## Executive Summary of the Method

---

*Please note: These procedures may be revised as the situation develops.*

Composting is a biological process that results in the natural degradation of organic resources (such as animal carcasses) by microorganisms. Composting has been successfully used throughout the United States for nearly two decades for routine mortalities and to control outbreaks of low pathogenicity avian influenza (LPAI) and highly pathogenic avian influenza (HPAI). Composting can be effective with most animal types.

Outdoor composting is accomplished by constructing windrows outside on a location that has been environmentally evaluated and approved. Outdoor composting requires the addition of relatively dry, high carbon organic materials such as animal bedding, wood shavings, or chipped brush and can be accomplished with carcasses that are whole, or that have undergone on-site particle reduction.

Microbial activity within a well-constructed compost pile can inactivate many pathogens. The effectiveness of this inactivation process can be assessed by evaluating compost temperatures, the shape of the time and temperature curve, visual observation of carcass decomposition, and the homogeneity of the compost mix.

Successful mortality composting requires the following:

1. A qualified composting expert to guide windrow construction.
2. Trained equipment operators.
3. Availability of appropriate equipment.
4. Sufficient carbon, water, and space.

**If any of these components is lacking, composting is NOT recommended.**

### SAFETY NOTICE



It is possible for high levels of ammonia to accumulate within closed barns prior to or during carcass management. Maximize natural ventilation by opening the doors and curtains to all the houses containing compost piles. If the structure has a ventilation system, turn system on for 30 minutes before entering. Allow enough time for the houses to air out before entering them. Before entering the structure, wear appropriate personal protective equipment (PPE) as recommended by a qualified safety professional in accordance with site-specific hazard assessment. Close the doors and curtains after completing the temperature readings.

Use the buddy system. Entering a barn with active compost or dead birds requires a two-person team. One person, with a cell phone, stays outside the house to monitor the person inside. Before anyone enters the barn, the monitor writes down the location so it can be given quickly to a 911 dispatcher in case of an emergency.

If the person inside is overcome, the monitor immediately calls 911 for assistance. Under no circumstances does the monitor enter the barn without a Self Contained Breathing Apparatus (SCBA). Do anything possible to increase ventilation inside the building while waiting for rescue personnel.

# Overview of Outdoor Composting Process

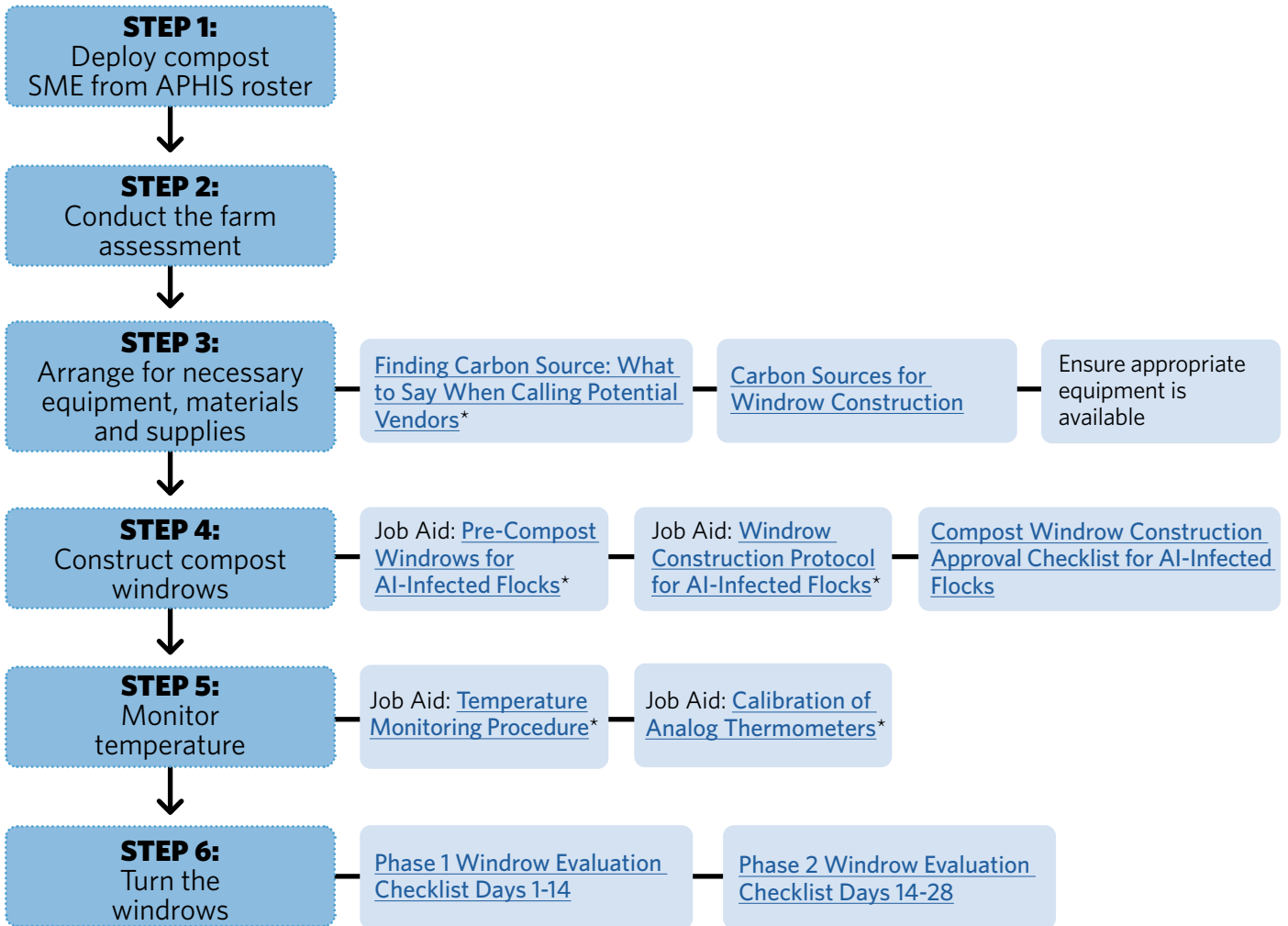

\*Clicking on this link will open the specific resource in a web browser.



# Conducting the Farm Assessment for Outdoor Composting

---

In order to plan for windrow construction at the affected premises, a Farm Assessment is required. The Farm Assessment may be developed and provided by the Site Manager or may be developed by a composting subject matter expert (SME) recognized by APHIS. The following components found within the assessment must be completed.

*Note: A check list is provided in [Appendix A](#) to assist with conducting the farm assessment.*

## EVALUATION

1. Evaluate potential outside compost sites (see [Appendix B](#)).  
*Note: If site modification is needed, then approval from State and local agencies may be required.*
2. If there are suitable sites, determine if there is adequate space for windrow construction. Compost action plans and compost implementation plans are valuable aids for estimating the space needed. See [Appendix D](#) for guidance in estimating space needs. A compost action plan and compost implementation plan aid in estimating space.
3. Evaluate the type and quantity of infected materials to be composted, including:
  - a. carcass: type, size, number, and condition;
  - b. in-barn manure/litter: volume, moisture content, and density;
  - c. stored manure/litter: volume, moisture content, and density;
  - d. routine mortality method, location, and physical condition of mortalities;
  - e. feed: quantity and location;
  - f. eggs: quantity and condition;
  - g. clean bedding; and
  - h. other organic products.
4. Calculate the amount of carbon needed for composting (see [Appendix B](#)).
5. Evaluate premises for supplemental water and include the source and application method.
6. Evaluate on-farm equipment availability and determine any supplemental equipment needs.

## ARRANGING FOR NECESSARY EQUIPMENT AND MATERIALS

Following a Farm Assessment, the SME coordinates with the Site Manager and requests additional resources through the Incident Management Team (IMT) Logistics Branch. The resource list includes, but is not limited to:

1. skilled equipment operators and general laborers;
2. skid loader(s), pay loaders, dump trucks, mixers, rakes and scoops;
3. sawdust, litter, wood shavings, active compost, woodchips, or other carbon material;
4. source of water if needed; and
5. compost thermometers (36" or 48" stem length)—(at least two per farm).

## KEY ELEMENTS FOR SUCCESSFUL COMPOSTING

The role of the SME is to ensure that these key elements are followed in the construction of compost windrows:

1. Windrows (typically 6 to 8 feet high and 12 to 15 feet wide) are constructed on an adequate and uniform base layer (10 to 15 inches thick) of a sufficiently porous and absorbent carbon material.
2. The base layer and windrow are not compacted with equipment. *Note: For large animals such as swine or bovine, the base may be 24 inches thick.*
3. For poultry or other small carcasses such as piglets, good carcass-to-carbon contact is ensured by creating a core with a minimum 1:1 mix, by volume, of carbon with carcasses, and other infected material (manure, egg shells, feed, etc.). For larger carcasses, contact may be achieved by ensuring that each carcass is surrounded above, below, and on all sides with the compost media, or if on-site particle reduction is allowed, by reducing the carcasses with a carbon source and then treating the mixture similar to poultry.
4. Windrows should be constructed to ensure adequate distribution of moisture throughout; cap windrows with carbon material (6 to 12 inches thick) to ensure that no carcasses or pieces are exposed and to minimize odor.
5. Windrow dimensions, including the base and cap, may be reduced for smaller carcasses.

## LABOR, EQUIPMENT, AND SUPPLIES

1. Skilled equipment operators and general laborers.
2. Skid loader(s), pay loaders, dump trucks, rakes, and scoops.
  - 200 feet from a water supply well used for drinking.
3. Sawdust, litter, wood shavings, corn stover, active compost, seed and nut hulls, woodchips, or other carbon material, and compost thermometers (36" or 48" stem length).

# Recommended Protocol for Outdoor Composting

---

## PRIOR TO WINDROW CONSTRUCTION

1. Calculate the amount of carbon needed for composting: See [Appendix C](#) for calculations.
2. Calculate space needed for windrow construction. See [Appendix D](#) for guidance in estimating space needs.
3. Assess the carbon materials available. The characteristics of various materials are listed in [Appendix I](#).
4. Layout proposed windrow locations and mark with flags or other means of indicating location and orientation.
5. Determine need for off-farm supplemental water source and means of application
6. Determine supplemental equipment needs. For handling livestock carcasses, one or more excavators with thumbs are recommended. Larger operations will need large payloaders for moving materials and pile construction and may require dump trucks (even side dump models) for moving materials to windrows away from the barns. See [Appendix H](#) for discussion of equipment types and applicability.
7. Place request for carbon, equipment, labor, and water resources from the Incident Command Logistics section through case manager or operations chief or other designated ICS personnel.
8. For large whole animals, lancing or perforating the abdomen to prevent bloating is required.

**TYPICAL WINDROW CONSTRUCTION PROTOCOL**

Three critical elements of windrow construction are:

1. a porous and absorbent base layer
2. the interior of the windrow consisting of the carcasses and suitable cover material (or media); and
3. in a disease event, an adequate cap of off farm material may be needed. (See Figures 1 & 2 for illustrations of piles for livestock and poultry.)

These steps may be done concurrently or as separate steps.

*(Terminology: To distinguish between the windrow cap and the active material in the interior of the windrow, the terms cover material or media are used. Cover material refers to the mix of materials that immediately surround whole carcasses, while media may be used to describe the same mix of materials when blended with ground carcasses or poultry. The cap is the layer of off-farm non-contaminated material that goes over the top of the cover or media.)*

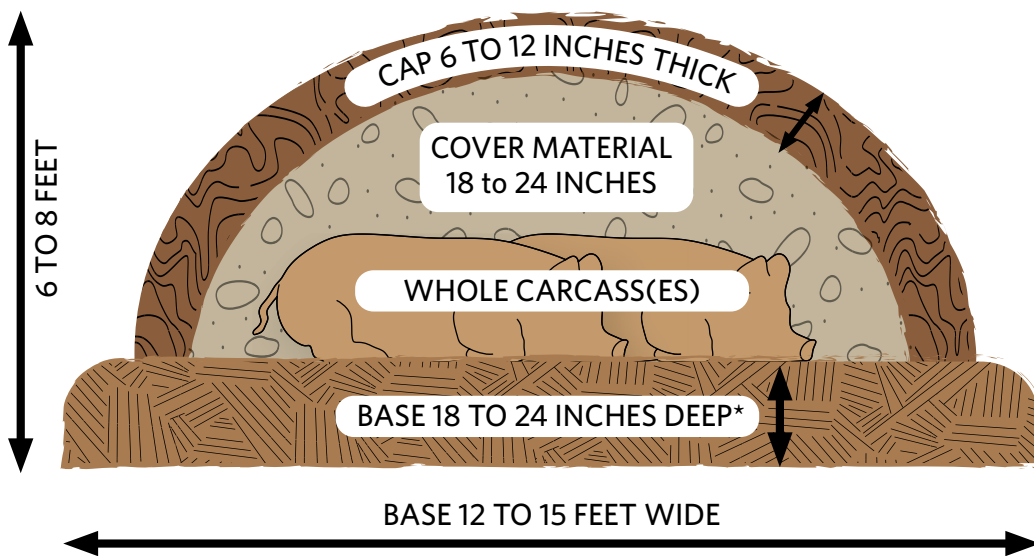

Figure 1. Completed livestock carcass windrow

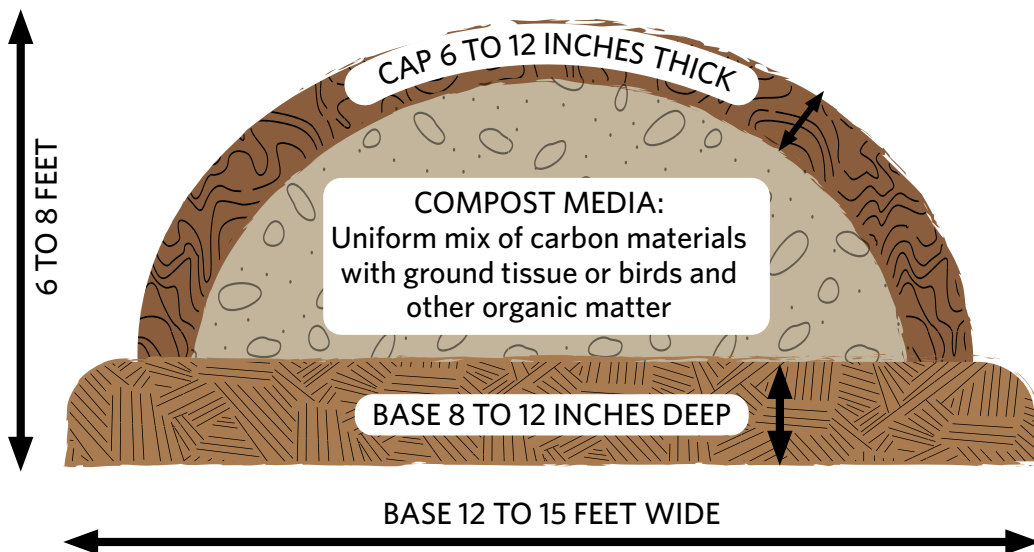

Figure 2. Completed windrow for poultry or carcass(es) that have undergone on-site particle reduction

\* The base for large animals such as swine or bovine is 18-24 inches, while 8-12 is often used for poultry.

## WINDROW ORIENTATION AND RUNOFF CONTROL

When building windrows outside, movement of water on the site during and after rainfall events must be considered. Windrows should be oriented so that runoff will pass between the windrows and not “pond” along them. To do this requires that the site have a gentle slope (2 - 4%) and that the windrows run up and down the slope rather than across it.

If there is a large area upslope from the compost site that will cause water to run onto the site, then the Natural Resource Conservation Service or other soil and water conservation organization should be consulted about the need for some type of water diversion measures to limit clean water from entering the site.

## WINDROW BASE CONSTRUCTION

1. Using the largest loader possible, begin building the windrow base.
2. Building a suitable base is the first and one of the most important steps in windrow construction. The base is responsible for both improving air flow into the pile and preventing leachate from leaving the windrow.
3. The windrow base should be 12 to 15 feet wide with a depth of 8 to 24 inches. (*Note: Base will compress over time.*) Base depth can vary depending on the contents of the pile core and the base material itself. 8 to 12 inches is often used for poultry. For large animals such as swine, a base of 18 to 24 inches may be needed. Windrows with larger animals or with a lot of wet material will need a deeper base than those with smaller carcasses and a drier core. Windrows with ground tissue and plenty of dry carbon in the core will also need less base. Base materials that do not have a mix of fines and coarser particles will likely need to be deeper to allow sufficient aeration and absorption. Windrows that contain manure, bedding, litter or feed but no carcasses only need the minimum amount of base since these materials are less likely to generate leachate and will likely allow better natural air flow in the windrow.
4. Carbon material for the base should be porous and bulky enough to allow adequate air flow into and through the windrow. It should also have enough finer material that will absorb any leachate generated. Acceptable materials include: bark mulch, chipped wood and brush, chopped straw, wood shavings, active compost, small grain hulls, and chopped corn stover. Since not all of these materials are both porous and absorbent, a combination of two (or more) of these materials may be necessary to provide both characteristics. Coarse woody material in excess of 2 inches in size should be avoided both because it will not be able to absorb leachate and it may prevent the resulting compost from being land-applied as a soil amendment. If these materials are not available, dry animal bedding may be used for the windrow base if it is sufficiently dry, porous, and bulky.
5. To maintain the base's porosity and to avoid compaction, **do not drive equipment on the base.** Ideally, windrows should be built from both sides. This allows the operators to reach the center of the windrow and avoid compacting the base with the tires or tracks of the loader.

## WINDROW CONTENT

- The windrow should consist of the carcasses and a suitable cover material or compost media. Suitable materials include fresh wood shavings, active compost, poultry litter, chipped green waste, dry animal bedding (especially mixed with waste feed), chopped straw, chopped corn stover, dairy separator solids, small grain hulls or similar materials. In many instances this material may need to be blended with additional materials to be suitable. See [Appendix I](#) for information on a variety of potential compost media materials.
- Any remaining infected feed that must be disposed of, should be blended and mixed with the carcasses and other cover materials before windrow construction. Be sure to move infected material as little as possible.

- For layer operations, if there are eggs to be disposed, it is important to include them in the core mixture at the outset. I.e., Do not leave them to be managed separately at a later time! (See discussion below.)
- If whole carcasses are being composted, the windrow should be constructed such that two feet of base material extends beyond the carcass(es) on both sides of the windrow. This helps ensure that when the cover material is applied and the windrow is capped no part of any carcass is too close to the edge of the windrow. Windrows should be dome-shaped.
- For large whole animal carcasses, lancing the abdomen is required to prevent bloating.
- If the windrow will be composed of a mixture of carcasses that have undergone on-site particle reduction and a carbonaceous compost media, the mixture should be placed on the base so that there is at least 12 inches of base exposed on both sides of the windrow. This is to ensure that no carcass tissue will be close to the surface once the cap is applied.
- If water needs to be added, it is best done during the mixing process but may also be done prior to mixing, depending on the circumstances. Adding water after the windrow is constructed and capped is very problematic, requiring equipment and corrective actions causing delays in schedule.
- If whole carcasses are being composted, the windrow, prior to capping, should be dome-shaped and of sufficient height to cover all carcasses with 18 to 24 inches of cover material. At this stage, the windrow height should not exceed 6 feet. The windrow should be roughly twice as wide as it is tall with distinguishable crest (i.e., no wide, flat windrows).
- If carcasses that have undergone on-site particle reduction are being composted in a compost media, the windrow, prior to capping, should be dome-shaped and the windrow height should not exceed 6 feet. The windrow should be roughly twice as wide as it is tall i.e., no wide flat windrows.

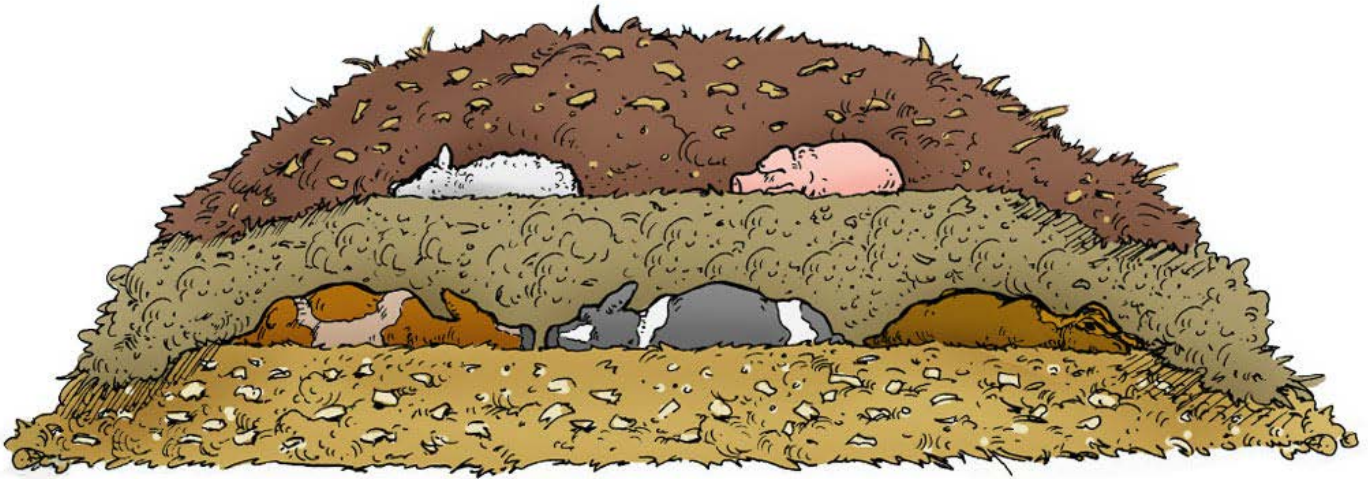

Example of compost layering (Cornell Waste Management)

## CAPPING THE WINDROW

In the case of a disease event, the windrow may need to be capped with off-farm materials if the cover material used to build the windrow is determined to be infected. Windrows containing ground carcasses mixed with a compost media will all need to be capped since some of the ground tissue is likely to be close to the surface when the mixture is applied to the base.



Constructing the Core (photo by Bob Peer)

1. Cap the windrow with 12 inches (poultry) or 12 to 18 inches (large animal) of a suitable carbon material. Carbon material for the cap should prevent flies from contacting carcasses, serve as an insulating blanket, and allow air to flow out of the piles. This material may be finer in texture than the base. Suitable material includes small grain hulls, sawdust, shavings, new bedding, chipped green waste, chopped straw, chopped corn stover, or similar material. Experience has shown that some of the lighter products can blow off the windrow if in a windy environment; the material may need to be thicker to serve this purpose than other materials.
2. Ensure that the entire windrow is uniformly covered with cap material with no carcasses or potentially infected material exposed. (To accomplish this, it is often necessary to have a worker on the ground dedicated to observing and measuring the cap depth as it is being applied.)
3. Do not operate equipment so that the tires or tracks ride up onto the sides of the windrow while capping.
4. The completed windrow should be approximately 6 to 8 feet high and 12 to 15 feet wide.

## FLAGGING THE WINDROW

Windrows should be numbered and flagged by the SME at temperature monitoring locations spaced equidistantly along the length of each windrow. In order to ensure that both sides of each windrow are observed, it is recommended that half of the flags be placed on each side of a windrow. For windrows that are 500 feet or longer, a minimum of 10 flag locations are required.

For shorter windrows, the SME may choose to flag fewer locations as long as they adequately represent the full length of the windrow. In no case should fewer than three locations be marked. (See [Appendix D](#) in Indoor Composting section for details.)

## MANAGING EGGS

On layer operations, there are likely to be large numbers of eggs that must also be disposed of. In order to compost the eggs, they must be broken prior to mixing with the other ingredients that make up the windrow. (Any unbroken eggs will not compost but will become “hard-boiled” during the compost process.) The process of mixing the eggs with manure, birds and/or feed may break some of the eggs but many will likely remain whole so some method of mechanically breaking them will be needed. This will vary depending on equipment and labor available. It is recommended that the eggs be broken on a layer of dry carbon to absorb the liquid and to facilitate mixing and subsequent movement to the windrow. **It is important that all eggs that must be disposed be done so along with other organic materials rather than leaving them to be managed alone.**

### PREPARATION OF LARGE CARCASSES (ON-SITE PARTICLE REDUCTION)

Operations composting larger carcasses should consider on-site particle reduction of the carcasses prior to mixing with bedding, manure, carbon materials, etc. Not only would this reduce particle size thereby speeding up the decomposition process, it reduces the amount of material needed for a base. If on-site particle reduction is to be done, the carcasses must be placed in the grinder along with an approximate equal volume of carbon material such as corn stover, brush, or shavings. The resulting blend can then be mixed with other material that will go into the windrow contents and placed on the pre-made base. *(Note: on-site particle reduction may not be allowed or allowed only with specific permission from state or federal authorities in some disease events. The SME is advised to consult with the appropriate Incident Command personnel prior to recommending on-site particle reduction in a disease event.)*

On-site particle reduction equipment for this purpose must be sized appropriately for the size and volume of carcasses to be managed. Horizontal feed grinders (often used for grinding stumps) have been used successfully since they can handle almost any size carcasses and allow carbon materials to be added at the same time. They can also be fed continuously so they have a high throughput rate. Vertical mixer wagons with knives have also been useful when a smaller volume needs to be managed, but their slower throughput limits their usefulness in a large event. Whatever on-site particle reduction equipment is being considered, it is important that the output is through a conveyor system that is as low to the ground as possible and does not “shoot” the ground product rather than allow it to drop onto a bed of carbon material.

### LAYERING METHOD FOR MID-SIZE CARCASSES

For mid-size carcasses such as deer, hogs, or sheep, more effective use of space and materials can be achieved by layering the carcasses with an appropriate cover material. Base and cap construction is the same as in the standard protocol. Following base construction, proceed in the following manner:

1. Place a layer of carcasses on the base as in the standard protocol, then cover with a 12 to 15 inch layer of cover material.
2. Add a second layer of carcasses.
3. Cover the final layer of carcasses with 18 to 24 inches of cover material, making sure that no carcass is less than 18 to 24 inches from the outside of the windrow. The finished windrow should be 6 to 8 feet high and 12 to 15 feet wide.

The SME may choose to use either the fully mixed or layered construction technique for mid-size carcasses or some combination of the two depending on the circumstances involved. *Note: Layering is not recommended for small carcasses, like poultry, since it is easier to blend the small carcasses with the compost media which also creates better contact between the birds and the media.*

### APPROVAL OF WINDROW DESIGN

SMEs should evaluate the windrows using the checklist in [Appendix G](#) to ensure that they have been constructed consistently with this protocol or the current USDA protocol for the event and based on the evaluation make a recommendation to the appropriate Incident Command official that the windrow construction should be approved and that Phase 1 of the composting process should begin. The recommendation should be documented on the Compost Approval Checklist in [Appendix G](#).

# Temperature Monitoring

---

## THERMOMETERS

During a disease outbreak, each premises should use at least two 36-inch compost thermometers for windrow monitoring. (If available, more thermometers per premises would greatly reduce the time needed to do the monitoring.) Prior to being put into service, each thermometer should be calibrated according to the manufacturer's instructions. The calibration may be done by any member of the logistics or operations team since it does not require specific knowledge of carcass composting techniques.) These thermometers should remain on the premises during the outbreak. *If a thermometer is moved from farm to farm, it must be disinfected thoroughly prior to leaving each premises and prior to entering another.*

## MONITORING PROTOCOL

Once the windrow has been capped, inspected and approved, daily temperature monitoring can begin following the standard temperature monitoring SOP found in [Appendix E](#). Temperature monitoring must be continued at least until the time/temperature standard has been met (see below). Temperature monitoring must be resumed at the start of Phase 2. Temperature data should be collected on the temperature log included in [Appendix F](#) or in a comparable electronic document.

## TIME/TEMPERATURE STANDARDS

The goal of the composting process is to create the level of beneficial microbial activity that will inactivate the pathogen in question. The easiest way to determine if that activity level has been achieved is to monitor the temperatures in the pile. In general, if the material in the pile both in the core and at the 18-inch depth has reached 131°F for three days, then the necessary level of activity has been achieved. At that point, if the windrow has met the other requirements established by USDA, the windrow can likely be moved into the next phase of the process. For whole large animals being composted it may take 3 to 4 weeks before achieving required temperatures and suitable decomposition. These standards may be modified by USDA for specific disease events which would be conveyed to all compost SMEs engaged in the process. *Note: An alternative standard that may be applied would be to achieve 110°F for 10 days. In order to meet this standard, it will likely require continuing to take temperatures for a longer time and may result in extending the time before a windrow may be moved into the next phase of the composting process.*

## MONITORING IN NON-DISEASE EVENTS

For events that do not involve a disease, temperature monitoring is still advised but strict adherence to a time/temperature standard may not be necessary. A record of the temperature profiles, however, is still very useful in managing the compost process.

# Timeline for Turning the Windrows

---

Turning windrows plays an important part in pathogen inactivation and the composting process. Turning homogenizes the core, base, and cap materials and allows adjustments to the media to ensure adequate porosity and moisture is maintained. The first turn marks the end of Phase 1, after which, the windrow is re-capped with new carbon material and starts the second phase of the process. The second turn marks the end of Phase 2 of the compost process; at this point the compost may be stockpiled, moved on the farm, or continued to be managed to produce a better product. (Movement off the farm at this



point may require permission from state, local, or federal authorities.) *Note: Large whole animal turning requirements are being evaluated and are not yet established. For large whole animals, the windrow should be constructed and capped, left for 8 to 12 weeks without turn.*

Clearance to turn a windrow is based upon a recommendation by the SME to the designated State official or Incident Command official, who gives the final approval. The recommendation and approval are documented on the checklist provided in [Appendix G](#).

The windrows should first be turned after meeting the requirements for the first phase of the composting cycle. For poultry, the turning at the end of Phase 1 could occur as soon as day 14, as long as the other standards are met. For large animals, the turning at the end of Phase 1 could be as soon as day 42, again, providing the other requirements have been met

The second turn can occur after meeting the requirements for Phase 2 of the composting cycle. For poultry, the turning at the end of Phase 2 could occur as soon as day 14 from the beginning of Phase 2, as long as the other standards are met. For large animals, the turning at the end of Phase 2 could be as soon as day 14 from the beginning of Phase 2, again, providing the other requirements have been met.

*Note: These turning timelines may be modified for particular events.*

## Release of the Compost

---

The release of a windrow from the disease inactivation protocol requires several steps. The SME must review the windrow design and performance as well as the temperature data from Phase 2. Based on these reviews, the SME then recommends that a windrow be released. Based on the recommendation from the SME, the appropriate SAHO, APHIS Official, or IMT Official can approve that the windrow be released. The release of the windrow indicates that the compost can be moved without restriction on the premises, can continue to be managed to create a final product, or may leave the premises with appropriate permits.

Document approval on the Compost Approval Checklist in [Appendix G](#).

## Transition from One SME to the Next During an Event

---

It is important, during the response to a catastrophic event that there is continuity of actions and planned actions throughout the event. Since an SME may be deployed at any point during the event, there must be a smooth transition from one SME to the next. In order to do this, there should be at least one day of overlap between the deployment times of the incoming and outgoing SMEs, plus the outgoing SME should provide both a copy of the Form 214 and discuss the basis for decisions that went into it. If a written management plan is available, that should be shared as well.

## Composting Manure, Waste Feed, and Other Potentially Infected On-farm Materials

---

During a disease outbreak, there may be a need to compost manure, waste feed or other infected organic materials. This may be because the producer has chosen to dispose of carcasses by a method other than composting, such as onsite burial, incineration, or landfilling, or because there was more manure or other organic materials on the farm than could be practically composted with the carcasses. In general, the compost process used for these materials is identical to the windrow construction process described above. However, because of the density of the manure and feed, it is imperative that the material be thoroughly blended with carbonaceous materials to help ensure proper porosity within the windrows. Generally, manure can be composted with a 1:1 mix of manure and bulky carbonaceous material.

Manure moisture content can vary from very wet to extremely dry depending on housing, age, type of litter or bedding, and manure management. Consequently, the moisture content of the materials may need to be adjusted prior to windrow formation. Fresh manure will often have a high moisture content compared to older manure which may be extremely dry and hard. In either situation the moisture content may have to be adjusted accordingly. Wet manure may require additional dry material such as wood shavings to absorb some of the excess liquid prior to being placed on a porous base. Dry manure should have water added as it is being mixed with a bulky carbon source such as wood chips to achieve the right moisture content and texture.

*(Note: Moisture content can be determined using a manual "squeeze test". To do a squeeze test, place a small amount (about a half cup) of material in the hand and squeeze firmly. If it is damp to the touch and forms a ball when released, the moisture is about right. If it releases water when squeezed, then it is too wet. If it is not damp to the touch and will not form a ball when released then it is too dry.)*

One departure from the protocol used when composting carcasses is the base layer under a windrow containing only manure, bedding, and/or waste feed. Manure has successfully been composted on farms for generations without a porous base. If it has been blended with sufficient volume of coarse material to create a porous mixture. It should be able to self-aerate with little or no base. Likewise, if the proper moisture has been achieved in the mix, there will, unlike carcasses, be no liquid released. Because of these factors, a minimal (2 to 4 inches) or no base should be required.

# Troubleshooting

Composting is a biological process. As such often airborne chemicals, namely odors, will be emitted and sensed. Odors occur because of the decomposition of the organic matter. These odorants are volatile organic compounds generated by the biological process and are an indication of anaerobic conditions. Many of the odorants are offense to most people and have unique descriptions such as putrid, sulfurous (dimethyl disulfide) or rotten fish (dimethylamine). Often the cure for these odorants is aeration and ensure cap integrity or use of a permeable membrane

Orientation of windrows is important and should be sited appropriately at the beginning of the planning process. Windrows should be oriented to be parallel with slope and contoured such that in a storm event the runoff will not pool or be discharged into a waterway. Some sites may benefit from implementing storm water pollution prevention techniques to control or divert away from the windrows precipitation from storm events.

The table below describes some of the most common composting problems and possible solutions.

Problem	Issue	Solution
Excessive flies or odor	Exposed carcasses	Add additional cap material
Leachate from windrow	Mixture too wet	Add additional carbon material, mix and cap
Temperature does not reach 131°F	Mixture too dry (< 40% moisture)	Add water to pile, mix if necessary
Temperature does not reach 131°F	Mixture too wet (> 60% moisture)	Add additional carbon material, mix if necessary
Temperature drops early	Not enough oxygen	Aerate or mix pile
Temperature records indicate low temps	Improper thermometer placement	Observe temperature taking and train technician or farmer in proper technique
Leachate from windrow	Poor or no base	Re-build on proper base
Temperature does not reach 131°F	Improper pile shape/flat pile	Reshape windrow and re-cap
Temperature does not reach 131°F at pile core	Pile too large	Split into two windrows with new bases and caps
Temperature does not reach 131°F	Base is not porous	Lay out new porous base and rebuild
Temperature too high (over 165°F)	Pile too dry	Add water
Temperature too high (over 165°F)	Pile too large	Split windrow into two
Pile too wet/poor heating	Standing water around pile	Move onto dry porous base away from standing water
Breaching, expansion of cap material	Animal stomach is bloating	Poke with long sharp pole, recover cap
Evidence of scavengers by digging	Carcasses too close to surface and not enough cap	Add extra cap

## Appendix A: Outdoor Composting Checklist

- Identify a suitable site on premises or in a centralized location in accordance with the checklist items below.
  - If off-site, complete site assessment in addition to secure transportation considerations and approval from State or USDA for permitted movement.
- Based on approval of the State environmental agency and the composting SME, are the site conditions suitable for composting the number of animals affected?)
  - See [USDA Mortality Composting Protocol for Avian Influenza Infected Flocks](#) or [USDA Livestock Composting Protocol](#) (also at [go.usdatraining.com/HPAI](http://go.usdatraining.com/HPAI)).
  - Adequate land area to build compost piles (assume (237) 1000-pound cows per acre, (1,185) 200-pound swine or sheep per acre, or (47,500) 5-pound poultry per acre) or refer to Carcass Management Dashboard at [go.usdatraining.com/Disposal](http://go.usdatraining.com/Disposal).
  - Required distance from water wells, surface water bodies (lakes, streams, rivers, etc.), sinkholes, seasonal seeps, or other landscape features that indicate the area is hydrologically sensitive, based on guidance from State environmental officials.
  - Consider all groundwater pathways including the presence of drain tiles, soil characteristics, depth to groundwater, use of groundwater, etc.
  - Located away from neighbors and/or out of sight.
  - Located downwind from neighbors and/or houses.
  - Located away from environmentally-sensitive areas.
  - Located close to the livestock or poultry facility or has clear access for transport.
  - Clear of overhead utility lines.
  - Void of excess water.
  - Located on a gentle slope (1%-4%) so there will be no water ponding.
  - Consider the need for an impermeable base and/or protective cover to prevent leachate generation and migration.
- Perform calculation to determine required space for composting is adequate.
- If the site is suitable, consider the duration of time it takes to fully compost and determine if the following issues can be overcome:
  - Personnel and equipment required to ensure proper construction, maintenance, and temperature monitoring of windrows.
  - Pest management.
  - Potential for extreme weather (e.g., hurricane) to disturb pile.
  - Inability to use the land area while composting.
- If so, is there a sufficient local supply of carbon source such as wood chips (1-2 pounds carbon source per pound of biomass)?
  - Check with local agencies and organizations to determine if stockpiles of carbon source are available (e.g., parks department, NRCS, Forest Service, landscape companies, and landfills). Ensure that the carbon source is free of any pests or pathogens which could threaten local species. See [Carbon Sources for Windrow Construction](#).

## Appendix B: Selecting a Carcass Compost Site

Prior to selecting an emergency compost site for carcass management, state and local environmental authorities should be consulted to determine if there are special requirements to be met or permits needed. (This should be done at the IC level rather than by the SME since it may require negotiations or policy adjustments.)



Compost site (photo by Mark King)

In general, emergency carcass compost sites should be large enough to accommodate all of the generated carcasses, litter, manure, bedding, waste feed, and other potentially infected materials, as well as have the ability to store any additional amendment materials that may be needed for successful composting. Along with the considerations noted above, ideal compost sites should meet the following:

- Be located close to the livestock or poultry facility or have clear access for transport.
- Be constructed or designated for the current emergency.
- Be located away from neighbors and/or out of sight.
- Be located such that the prevailing wind directions do not travel to nearby residences (whenever possible).
- Be located away from environmentally-sensitive areas.
- Have the following minimum setbacks: (Check with state and local environmental authorities for local requirements that may differ.)
  - 200 feet from a water supply well used for drinking;
  - 200 feet from water bodies, including: ponds, lakes, streams, rivers;
  - 200 feet from a nearby residence (not owned by the premises);
  - 50 feet from a drainage swale that leads to a water body (see above); and
  - 25 feet from a drainage swale that does not lead to a water body.
- Not be located on fields with drain tiles.
- Not have standing water or be excessively wet.
- Not be located on a flood plain.
- Be located on moderately-well to well drained soils (usually land that is used for crop production).
- Have a gentle 2%–4% slope to encourage on-site drainage.
- Have on-site soil depths in excess of 24 inches to seasonal high-water tables.
- Have on-site soil depths in excess of 36 inches to bedrock.
- Be clear of overhead utility lines.
- Be located at the top of the slope of the field.

If the best site location is not available, you may have (or construct) diversion ditches, terraces, or berms to direct surface water flows and storm water away from active compost piles. *(Note: If piles are located between production houses, then roof and surface drainage should be directed away from the compost area).*

In many cases no site will perfectly meet all these requirements. It may require prioritization of setback needs to settle on the best of the available sites and may require some site modifications to be acceptable.

*Note: Please check with your state environmental regulators for setback requirements. Each state may have special requirements.*

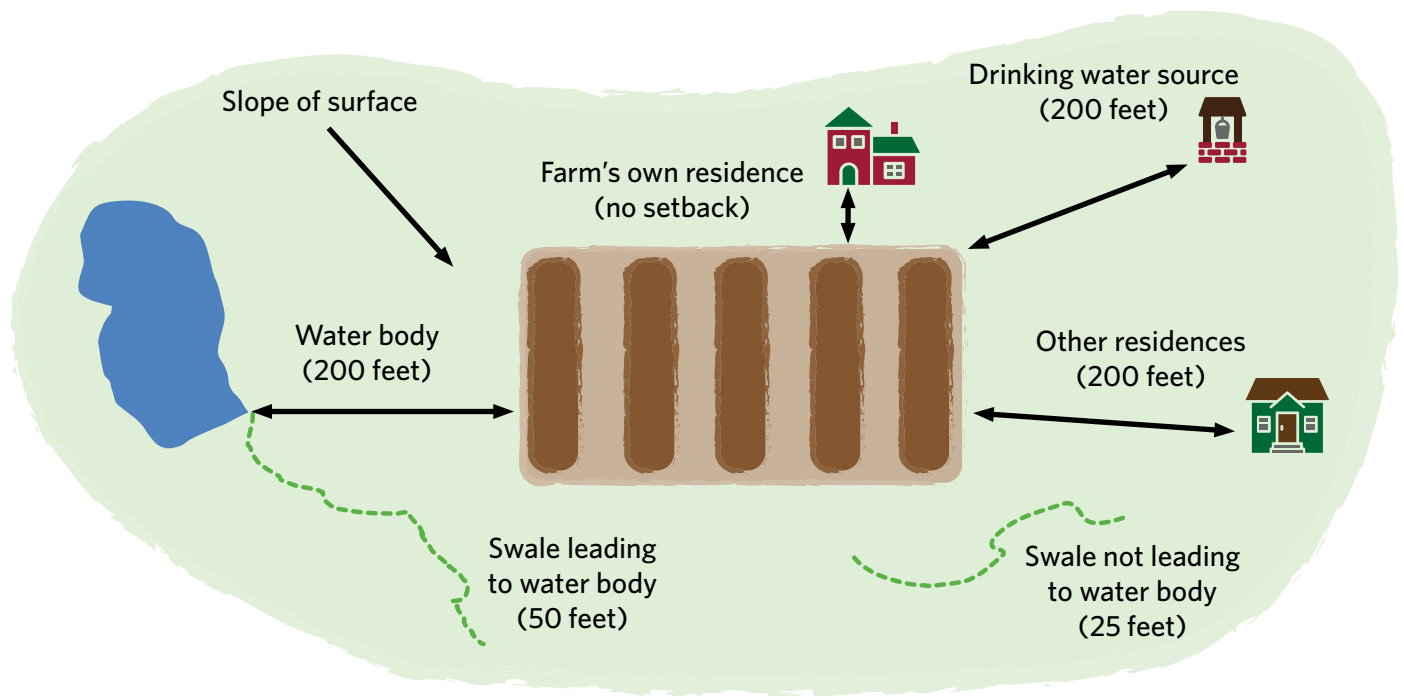

Figure 3. Setbacks for Carcass Compost Sites

*Note: If possible, the windrows should be constructed parallel with the slope of the surface to prevent accumulation of moisture. In cold environments, windrows should be constructed perpendicular to the sun such that both sides of the windrow will benefit from the sun.*

## Appendix C: Estimating Carbon (Bulking Agent) Needs

---

### EXECUTIVE SUMMARY

Estimating carbon needs is a process to determine how much carbon material is needed per animal unit. An AU is 1000 pounds of animal weight. This approach eliminates the need to develop estimates for different species or animal sizes.

Estimates are broken down by the portion of the compost windrow that is being constructed. Windrows generally will have three segments, the base, the cap and the cover material (or compost media). The base is the layer that is laid down on the ground or compost pad. It must be porous enough to allow the windrow to naturally aerate but absorbent enough to control any liquids released. The cap is the final layer of material, composed of non-infected material, that is used to insulate the windrow, control odors, and deter vectors. The cover material (also called the compost media) is the material that is mixed with the carcasses or surrounds the carcasses and provides the carbon and energy needed for the compost process.

### METHODOLOGY: VOLUME ESTIMATE BASED ON ANIMAL UNITS

*Note: This methodology is rule of thumb and is not intended to be exact. There are several calculators that can be used to aid in the estimation process:*

1. Calculate the number of AUs to be composted:
  - Multiply the number of animals by the average weight in lbs for each different size group to get total animal weight.
2. Divide total animal weight by 1000 to get total AUs.
3. Calculate volume of carbon needed for cover material\*:
  - $\text{Total AUs} \times 2.6 + 3 = \text{volume of cover material needed in cubic yards}$
4. Calculate volume of carbon material needed for base\*:
  - $\text{Total AUs} \times 2.2 + 3 = \text{volume of base material needed in cubic yards}$
5. Calculate volume of carbon material needed as a cap\*:
  - For a 4" cap:  $\text{volume} = 0.74 \times \text{AU} + .75$
  - For a 6" cap:  $\text{volume} = 1.1 \times \text{AU} + 1.1$
  - For a 8" cap:  $\text{volume} = 1.47 \times \text{AU} + 1.5$
  - For a 10" cap:  $\text{volume} = 1.84 \times \text{AU} + 1.85$
  - For a 12" cap:  $\text{volume} = 2.21 \times \text{AU} + 2.25$
6. Calculate total volume of carbon needed in cubic yards by adding carbon for the cover, the base and the cap.

*\*Note: On-farm carbon materials may be used as part of the cover material but cap material in a disease event must be from an uncontaminated off-farm source. Base material should also be from off-farm sources if possible.*

## Appendix D: Estimating Space Requirements for Compost Windrows Based on Animal Units

---

### METHODOLOGY

1. Establish basic parameters for site layout:
  - a. Determine the usable length in feet of potential compost site(s), remembering to allow about 20 feet on each end for equipment movement.
  - b. Determine proposed windrow widths in feet (will generally be about 12 feet unless animal sizes dictate otherwise).
  - c. Determine proposed alley widths in feet based on type of equipment to be used:
    - Consult with equipment operators, if possible, to establish space needs
    - If unknown use 12 feet for estimating purposes
2. Estimate of number of AUs in each weight class:
  - $AU \text{ in that weight class} = \# \text{ of animals} \times \text{average weight in pounds} \div 1000 \text{ lbs}$
3. Add together the number of AUs in all weight classes to get total number of animal units.
4. Calculate the total length of windrow required in feet (assuming a typical windrow will be 12 feet wide by 6 feet tall.)
  - a.  $\text{Total number of linear feet of windrow} = 3.2 \times AU + 4$
  - b. Optional: add 10 to 20% to account for inaccurate placement and other variables in the field.
5. Estimate the number of windrows needed to compost materials:
  - a.  $\text{Number of windrows} = \text{total windrow length} \div \text{length of available space}$
  - b. Round up to the nearest whole number of windrows
6. Estimate the width of the space required for the windrows:
  - a. For windrows laid out with an alley between every windrow and on the outside:
    - $\text{Width of area needed for windrows and Alleys in feet} = (\text{width of windrow} \times \# \text{ of windrows}) + (\text{width of alley} \times (\# \text{ of windrows} + 1))$
  - b. For windrows laid out with an alley between each windrow but no outside alleys:
    - $\text{Width of area needed for windrows in feet} = (\text{width of windrow in feet} \times \# \text{ of windrows}) + (\text{width of alley in feet} \times (\# \text{ of windrows} - 1))$
  - c. For windrows laid out in PAIRS with a one foot space between members of each pair and an alley between each pair and one outside alley:
    - $\text{Width of area needed for windrows in feet} = ((\text{width of windrow}) \times 2 + 1) \times (\# \text{ of windrows}) \div 2 + (\text{width of alley} \times (\# \text{ of windrows} \div 2))$
7. Acreage needed can be calculated:
  - $\text{Acres} = \text{space length} \times \text{space width} \div 43560$



## Appendix E: Temperature Monitoring Procedure

Monitor temperatures of the windrow daily at locations flagged by the SME. The temperature monitoring locations should be spaced equidistantly along the length of each windrow. In order to ensure that both sides of each windrow are observed, it is recommended that half of the flags are placed on each side of a windrow. For windrows that are 500 feet or longer, a minimum of 10 flag locations are required. (See Figure 4 below for two potential flag arrangements that would achieve this goal.) For shorter windrows, the SME may choose to flag fewer locations as long as they adequately represent the full length of the windrow. In no case should fewer than three locations be marked. (*Note: This procedure applies to carcass windrows constructed with either whole carcasses, as indicated in Figure 5 or ground carcasses.*)

Take two temperature readings at each flagged location within one foot of the flag; one reading at a depth of 18 inches and another reading at a depth of 36 inches. To ensure consistent temperature monitoring to the same depth, mark the thermometer probe at 18 inches and 36 inches. Place the temperature probe  $\frac{3}{4}$  of the way up the windrow at a 45-degree angle. Ideally, temperatures should be monitored by a single individual for consistency. Temperature probes should be calibrated before being put into service and if there is any concern about the accuracy of the readings.

The goal of taking the temperatures is to gauge the activity in the most active zone (18-inch depth) and in the pile core. For windrows that are not 12 feet wide, the depth of the deeper reading should be adjusted based on the pile width. Typical windrows that are 6 feet high and 12 feet wide at the base would be monitored at the 36-inch depth. Piles that are more than one foot narrower or wider than 12 feet should be monitored at depths that are approximately  $\frac{1}{4}$  the pile width. E.g., A windrow that is 16 feet wide should be monitored at the depth of 48 inches, while a windrow that is only 8 feet wide should be monitored at 24 inches.

### Flagging Windrows for Temperature Monitoring

#### OPPOSITE ARRANGEMENT



#### STAGGERED ARRANGEMENT



Figure 4. Recommended flag placement locations

**INSTRUCTIONS FOR TAKING WINDROW TEMPERATURES**

1. Place the tip of the thermometer approximately 18 inches into the compost pile about  $\frac{3}{4}$  the way up the pile at a 45-degree angle. After obtaining the 18-inch reading, push the thermometer into the pile so that the tip is in the pile core. (See discussion above.)
2. Leave the thermometer at each depth and point for at least 60 seconds.
3. Log the thermometer reading at each flag and at both depths.

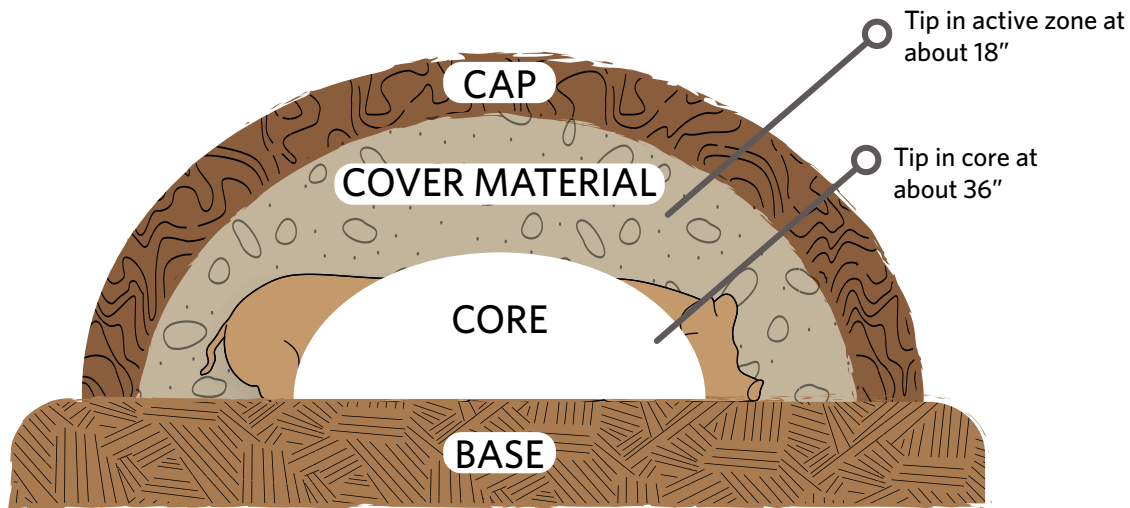

Figure 5. Thermometer placement in carcass windrow

4. Compare readings to previous day's readings.
5. After completing the house readings, be sure that the doors and curtains are closed.
6. Calculate the average temperatures for each pile by averaging each depth separately and note them on the Composting Temperature Log.
7. Windrows should reach average temperatures of 131 °F for a minimum of three days at the 18 inch depth and at the core sometime in the first 14 days of composting. (These do not necessarily need to be consecutive or concurrent). If the temperature profiles suggest that one or both averages will not reach 131 °F by day 14 the windrow should be assessed by a SME for possible corrective measures.
8. Disinfect the thermometer and return it to its protective case.
9. Each thermometer will be kept at the respective premises being monitored. Do not take a thermometer from one premises to another.
10. If, beginning 3 days after initial windrow construction, compost temperature averages are consistently (more than 3 days) below 100 °F or greater than 160 °F, an SME should be consulted immediately.
11. During Phase 2, an SME should be consulted immediately if any monitoring location is consistently (more than 3 days) below 100 °F or greater than 160 °F.

# Appendix F: Temperature Monitoring Log Sheet

COMPOSTING TEMPERATURE LOG																																																																																																																																																																																																															
County:				Site Number:																																																																																																																																																																																																											
Street address, city, state:																																																																																																																																																																																																															
Farm Name:																																																																																																																																																																																																															
House/Window Number:			Date Started:			Date Finished:			Date Turned:																																																																																																																																																																																																						
Use the cells below to record the temperatures each day at 18 inches and at 36 inches.																																																																																																																																																																																																															
Date	Depth	Flag #1	Flag #2	Flag #3	Flag #4	Flag #5	Flag #6	Flag #7	Flag #8	Flag #9	Flag#10	Avg																																																																																																																																																																																																			
	18"													36"													18"													36"													18"													36"													18"													36"													18"													36"													18"													36"													18"													36"													18"													36"											
	36"													18"													36"													18"													36"													18"													36"													18"													36"													18"													36"													18"													36"													18"													36"																								
	18"													36"													18"													36"													18"													36"													18"													36"													18"													36"													18"													36"													18"													36"																																					
	36"													18"													36"													18"													36"													18"													36"													18"													36"													18"													36"													18"													36"																																																		
	18"													36"													18"													36"													18"													36"													18"													36"													18"													36"													18"													36"																																																															
	36"													18"													36"													18"													36"													18"													36"													18"													36"													18"													36"																																																																												
	18"													36"													18"													36"													18"													36"													18"													36"													18"													36"																																																																																									
	36"													18"													36"													18"													36"													18"													36"													18"													36"																																																																																																						
	18"													36"													18"													36"													18"													36"													18"													36"																																																																																																																			
	36"													18"													36"													18"													36"													18"													36"																																																																																																																																
	18"													36"													18"													36"													18"													36"																																																																																																																																													
	36"													18"													36"													18"													36"																																																																																																																																																										
	18"													36"													18"													36"																																																																																																																																																																							
	36"													18"													36"																																																																																																																																																																																				
	18"													36"																																																																																																																																																																																																	
	36"																																																																																																																																																																																																														

## Appendix G: Compost Approval Checklists

---

The following checklists are to be used by a person who has personally reviewed the windrows on-site to submit recommendations for each phase of the composting process. Preferably this would be a composting SME but may be a designee if necessary. The checklists should be submitted to Incident Command through the farm case manager, operations chief, or other appropriate Incident Command Official for each windrow being built and managed. After the Incident Commander or designee has made the final approval/disapproval, the checklists should be maintained as part of the incident record keeping.

# Initial Compost Windrow Construction Checklist

Premises ID:	Special ID:
Premises Name:	
Prem Address:	
Prem Contact (Name / Phone #):	
Date Windrows Started:	Date Windrows Completed:
Windrow #:	
Who built windrow?	Contact Info:

	WINDROW DESIGN	Yes	No	N/A	Comments/Description
1	Height between 6 and 8 feet	<input type="checkbox"/>	<input type="checkbox"/>	<input type="checkbox"/>	
2	Width between 10 and 15 feet	<input type="checkbox"/>	<input type="checkbox"/>	<input type="checkbox"/>	
3	Base between 8 and 12 inches	<input type="checkbox"/>	<input type="checkbox"/>	<input type="checkbox"/>	
4	Dome shaped without significant irregularities	<input type="checkbox"/>	<input type="checkbox"/>	<input type="checkbox"/>	
5	No soft tissue visible on the surface of the windrow	<input type="checkbox"/>	<input type="checkbox"/>	<input type="checkbox"/>	
6	A minimum of 6 inches of carbon cover material	<input type="checkbox"/>	<input type="checkbox"/>	<input type="checkbox"/>	
7	Photos taken	<input type="checkbox"/>	<input type="checkbox"/>	<input type="checkbox"/>	
8	Attached sketch of flag locations and windrow dimensions	<input type="checkbox"/>	<input type="checkbox"/>	<input type="checkbox"/>	
9	Windrow core had acceptable moisture level	<input type="checkbox"/>	<input type="checkbox"/>	<input type="checkbox"/>	

## Recommendations:

- I have observed the windrows at this site and in my professional judgment they have been constructed consistent with the criteria outlined in the Mortality Composting Protocol for Avian Influenza Infected Flocks.
- I have observed the windrows at this site and in my professional judgment they have **NOT** been constructed consistent with the criteria outlined in the Mortality Composting Protocol for Avian Influenza Infected Flocks. The following corrective actions are recommended:

Signature of Composting SME: \_\_\_\_\_ Date: \_\_\_\_\_

Printed Name of Composting SME: \_\_\_\_\_

-----

The corrective actions recommended above were completed on: \_\_\_\_\_

Signature of Composting SME: \_\_\_\_\_ Date: \_\_\_\_\_

# Phase 1 Windrow Approval Checklist

**Applicability:** This checklist is to be used 14 days after windrow construction to verify that they have been constructed in accordance with the protocol and have reached temperatures necessary for virus inactivation.

Premises ID:	Special ID:
Premises Name:	
Prem Address:	
Prem Contact (Name / Phone #):	
Date Windrows Started:	Date Windows Completed:
Windrow #:	
Who built windrow?	Contact Info:

	PHASE 1 WINDROW EVALUATION – Days 1-14	Yes	No	N/A	Comments/Descriptions
1	Height between 4 and 8 feet	<input type="checkbox"/>	<input type="checkbox"/>	<input type="checkbox"/>	
2	Width between 10 and 15 feet	<input type="checkbox"/>	<input type="checkbox"/>	<input type="checkbox"/>	
3	Dome shaped without significant irregularities	<input type="checkbox"/>	<input type="checkbox"/>	<input type="checkbox"/>	
4	No soft tissue visible on the surface of the windrow	<input type="checkbox"/>	<input type="checkbox"/>	<input type="checkbox"/>	
5	A minimum of 6 inches of carbon cover material	<input type="checkbox"/>	<input type="checkbox"/>	<input type="checkbox"/>	
6	Moisture adequate	<input type="checkbox"/>	<input type="checkbox"/>	<input type="checkbox"/>	
7	Leachate present	<input type="checkbox"/>	<input type="checkbox"/>	<input type="checkbox"/>	
8	Excessive flies	<input type="checkbox"/>	<input type="checkbox"/>	<input type="checkbox"/>	
9	Vector activity observed	<input type="checkbox"/>	<input type="checkbox"/>	<input type="checkbox"/>	
10	Odor observed: VOA, putrid	<input type="checkbox"/>	<input type="checkbox"/>	<input type="checkbox"/>	
11	Temperature measured at 18 inches and 36 inches	<input type="checkbox"/>	<input type="checkbox"/>	<input type="checkbox"/>	
12	Temperatures reached 131 °F for 3 consecutive days	<input type="checkbox"/>	<input type="checkbox"/>	<input type="checkbox"/>	
13	Was there a major storm even during this period	<input type="checkbox"/>	<input type="checkbox"/>	<input type="checkbox"/>	
14	Photos taken	<input type="checkbox"/>	<input type="checkbox"/>	<input type="checkbox"/>	
15	Windrow(s) have been in place for at least 14 days after initial construction build	<input type="checkbox"/>	<input type="checkbox"/>	<input type="checkbox"/>	

**Phase 1 Recommendations of State Animal Health, APHIS, or IMT Official:**

I have reviewed the windrow compost temperature logs and other associated documentation presented by the SME. The windrows have performed in a manner demonstrated to inactivate the avian influenza virus. The 14-day initial composting cycle is complete.

I have reviewed the windrow compost temperature logs and other associated documentation presented by the SME. The windrows have **NOT** performed in a manner demonstrated to inactivate the avian influenza virus. The windrow(s) should be evaluated by a composting Subject Matter Expert to recommend corrective actions if necessary.

**Signature of State Animal Health Official**

APHIS Official, or IMT Official: \_\_\_\_\_ Date: \_\_\_\_\_

Printed name of signing official: \_\_\_\_\_

## Continuation Phase 1 Recommendations of Subject Matter Expert:

I have observed the windrows at this site and based on their construction and my review of the temperature logs and/or other associated information the windrows have performed in a manner demonstrated to inactivate the avian influenza virus. The 14-day initial composting cycle is complete.

I have observed the windrows at this site and based on their construction and my review of the temperature logs and/or other associated information the windrows have NOT performed in a manner demonstrated to inactivate the avian influenza virus. The following corrective actions below are recommended:

Signature of Composting SME: \_\_\_\_\_ Date of windrow evaluation: \_\_\_\_\_

End date of phase 1: \_\_\_\_\_

Printed name of Composting SME: \_\_\_\_\_



### Corrective Action Verification

The corrective action(s) recommended above were completed on: \_\_\_\_\_

Phase 1 corrective action(s) were verified on: \_\_\_\_\_

Signature of Composting SME: \_\_\_\_\_ Date: \_\_\_\_\_

# Phase 2 Windrow Approval Checklist

**Applicability:** This checklist is to be used 14 days after Phase 1 was completed to verify that the compost windrows may be moved without restriction on the premises or may leave the premises with appropriate permits.

Premises ID:	Special ID:
Premises Name:	
Prem Address:	
Prem Contact (Name / Phone #):	
Date Windrows Started:	Date Windows Completed:
Windrow #:	
Who built windrow?	Contact Info:

	PHASE 2 WINDROW EVALUATION – Days 14-28	Yes	No	N/A	Comments/Descriptions
1	Height between 4 and 8 feet	<input type="checkbox"/>	<input type="checkbox"/>	<input type="checkbox"/>	
2	Width between 10 and 15 feet	<input type="checkbox"/>	<input type="checkbox"/>	<input type="checkbox"/>	
3	Dome shaped without significant irregularities	<input type="checkbox"/>	<input type="checkbox"/>	<input type="checkbox"/>	
4	No soft tissue visible on the surface of the windrow	<input type="checkbox"/>	<input type="checkbox"/>	<input type="checkbox"/>	
5	A minimum of 6 inches of carbon cover material	<input type="checkbox"/>	<input type="checkbox"/>	<input type="checkbox"/>	
6	Moisture adequate	<input type="checkbox"/>	<input type="checkbox"/>	<input type="checkbox"/>	
7	Leachate present	<input type="checkbox"/>	<input type="checkbox"/>	<input type="checkbox"/>	
8	Excessive flies	<input type="checkbox"/>	<input type="checkbox"/>	<input type="checkbox"/>	
9	Vector activity observed	<input type="checkbox"/>	<input type="checkbox"/>	<input type="checkbox"/>	
10	Odor observed: VOA, putrid	<input type="checkbox"/>	<input type="checkbox"/>	<input type="checkbox"/>	
11	Temperature measured at 18 inches and 36 inches	<input type="checkbox"/>	<input type="checkbox"/>	<input type="checkbox"/>	
12	Temperatures reached 131°F for 3 consecutive days	<input type="checkbox"/>	<input type="checkbox"/>	<input type="checkbox"/>	
13	Was there a major storm event during this period	<input type="checkbox"/>	<input type="checkbox"/>	<input type="checkbox"/>	
14	Photos taken	<input type="checkbox"/>	<input type="checkbox"/>	<input type="checkbox"/>	
15	Windrow(s) have been in place at least 14 days after turning	<input type="checkbox"/>	<input type="checkbox"/>	<input type="checkbox"/>	

**Phase 2 Recommendations of State Animal Health, APHIS, or IMT Official:**

- I have reviewed the windrow compost temperature logs and other associated documentation presented by the SME. The windrows have performed in a manner demonstrated to inactivate the avian influenza virus. The second 14-day composting cycle (day 28) is complete. The windrows may be moved without restriction on the premises or may leave the premises with appropriate permits.
- I have reviewed the windrow compost temperature logs and other associated documentation presented by the SME. The windrows have **NOT** performed in a manner demonstrated to inactivate the avian influenza virus. The windrows should be evaluated by a composting Subject Matter Expert to recommend the corrective actions if necessary.

**Signature of State Animal Health Official**

APHIS Official, or IMT Official: \_\_\_\_\_ Date: \_\_\_\_\_  
 Printed name and organization of signing official: \_\_\_\_\_



## Continuation Phase 2 Recommendations of Subject Matter Expert:

I have observed the windrows at this site and based on their construction and my review of the temperature logs and/or other associated information, the windrows have performed in a manner demonstrated to inactivate the avian influenza virus. Recommend the windrows may be moved without restriction on the premises or may leave the premises with appropriate permits.

I have observed the windrows at this site and based on their construction and my review of the temperature logs and/or other associated information the windrows have **NOT** performed in a manner demonstrated to inactivate the avian influenza virus. The following corrective actions below are recommended:

Date of windrow evaluation: \_\_\_\_\_

Signature of Composting SME: \_\_\_\_\_ Date: \_\_\_\_\_

Windrow release Date: \_\_\_\_\_

Printed name of Composting SME: \_\_\_\_\_



### Corrective Action Verification

The corrective action(s) recommended above were complete on: \_\_\_\_\_

Phase 2 corrective action(s) were verified on and windrow can be released: \_\_\_\_\_

Signature of Composting SME: \_\_\_\_\_ Date: \_\_\_\_\_

Phase 2 was complete on: \_\_\_\_\_

Signature of Composting SME: \_\_\_\_\_ Date: \_\_\_\_\_

## Appendix H: Windrow Turning Equipment and Methods

---

### TIMING OF TURNING

Windrow turning should occur after the windrow construction is completed, when most of the soft tissue has been degraded and a time/temperature standard has been met. For poultry, the time before the first turn will generally be 14 days with a second turn after an additional 14 days. For livestock, the time before the first turn (end of Phase 1) will be 42 days (six weeks) unless otherwise directed by USDA. The time for the second turn (end of Phase 2) for livestock should be the same as for poultry or 14 days unless otherwise directed by USDA. Although disease inactivation should have been achieved by the end of Phase 2, additional turning after Phase 2 will be needed to complete the compost process. The timing and methods should be determined to meet the farm operation needs and goals. (Generally turning about once a week for 6 weeks is recommended if a quality compost product is desired at the end of the process.)

### PRIOR TO TURNING

Before discussing turning strategies, the SME must make sure the operators know the requirements for completing Phase 2 of the composting process. Specifically make sure that they know:

1. No new base is needed unless windrow is unusually wet.
2. The finished windrow width must be 10 feet to 15 feet wide.
3. The windrow height at the end of the process must be 4 feet to less than 8 feet (which means that newly constructed height will need to be at least 5 feet high due to pile shrinkage).
4. The pile must be dome-shaped with the height roughly half the pile width (i.e., no wide flat windrows).
5. There must be no exposed putrescible tissue.
6. A cap (6 inches) may be needed if there is a significant amount of exposed tissue.

### METHODS FOR TURNING WINDROWS OUTSIDE

There are several types of equipment and methods for turning outside windrows. The strategy for efficiently turning outside will depend on the space available, the number of existing windrows in that space, the type of equipment to be used, and operator skills and preferences. It is recommended that the SME consult with the lead equipment operator on the most effective strategy for turning in each specific situation.

As with in-door turning, just pushing an existing windrow a few feet to one side does not constitute "turning". In order to get a thorough mix of all the ingredients, the whole profile of the windrow must be lifted and dropped in such a way that the base, core, and cap are thoroughly mixed. The material must then be placed in a new windrow of the proper size and shape for effective composting.

### EQUIPMENT FOR TURNING WINDROWS OUTSIDE

Regardless of type of event, carcass type, windrow dimensions or composition, and equipment will be required to accomplish the task. Different types of emergency events may have specific concerns associated with turning that may limit the types of equipment that is allowed. An example would be the concerns about aerosolization of virus particles associated with high path avian influenza. USDA should be consulted prior to recommending equipment such as mechanical mixers or turners.

Turning windrows outside is more flexible than turning in a building because of the extra space that is generally available. Larger and/or specialized equipment may be used to speed up the turning process. Although skid loaders could also be used outside, their smaller bucket sizes and limited usefulness on rough ground make them less attractive for managing large outdoor windrows.

Here are some of the pros and cons of some types of equipment that may be used for turning windrows:

1. Large articulated loader(s):
  - a. Can manage large windrows on almost any compost site.
  - b. Care is needed to avoid picking up large amounts of soil while turning.
  - c. Requires extra space between windrows.
  - d. Requires moving windrow at least several feet.
  
2. Large non-articulated loader(s):
  - a. Can manage large windrows on almost any compost site.
  - b. Less maneuverable than articulated loaders.
  - c. Care is needed to avoid picking up large amounts of soil while turning.
  - d. Requires extra space between windrows.
  - e. Requires moving windrow at least several feet.
  
3. Tractor-attached mechanical compost turner:
  - a. Thoroughly mixes and shreds material but may be slower than using large loaders or straddle type windrow turners.
  - b. Allows turning windrow on the same footprint as original windrow.
  - c. Can be used on sites not suitable for self-propelled turners.
  - d. Most cannot accommodate windrows greater than 6 feet high.
  - e. Automatically creates a windrow of the right shape as well as smoothing out any irregularities of the original windrow.
  - f. Windrows should be constructed far enough apart to allow the tractor and turner to operate (width of tractor approximately 10 to 12 feet).
  - g. A large unit to turn 12 to 15 foot windrows (at least 14 foot wide)—the “toe” of the windrows can be removed by a loader to reduce the width of larger windrows.
  - h. Requires 2 passes for larger windrows.
  
4. Large self-propelled straddle type mechanical compost turner:
  - a. Thoroughly mixes and breaks up lumps.
  - b. Able to quickly create the most thorough mix and improve end-product quality at same time.
  - c. Does not work well on rough or uneven ground.
  - d. Best suited to long, hard, flat surfaces.
  - e. Allows turning windrow on the same footprint as original windrow.
  - f. Larger models can accommodate windrows greater than 6 feet high but not efficient for small windrows.
  - g. Automatically creates a windrow of the right shape as well as smoothing out any irregularities of the original windrow.
  - h. A large unit to turn 12 to 15 foot windrows (at least 14 foot wide)—the “toe” of the windrows can be removed by a loader to reduce the width of larger windrows.
  - i. Some models can add moisture as windrow is being turned.

5. Other types of equipment such as feed mix wagons, manure spreaders, litter spreaders, and vertical mixers:
  - a. Can be used in conjunction with payloaders or tractors to achieve a more thorough blend and a better end product.
  - b. May add another step to the turning process.
  - c. Often already available on farms.
  - d. Can sometimes be used to form the new windrow as it is unloading.
  
6. Side-dump dump trucks:
  - a. Useful for moving mixed material when mixing is done in a stationary location.
  - b. Can add mixed material to a windrow by driving along side.
  - c. No backing up to dump so saves time.
  - d. Especially useful if material needs to be moved a distance.



Brown Bear compost turner (photo by Gary Flory)



Brown Bear compost turner (photo by Bob Peer)



Self-propelled compost turner (photo by Gary Flory)



Tractor-pulled compost turner (photo by Mark King)

# Appendix I: Compost Feedstocks

## CARBON SOURCES FOR WINDROW CONSTRUCTION

*Note: These procedures may be revised as the situation develops; this is a list of generally acceptable carbon sources for windrow composting of HPAI-related mortalities. The carbon source resource needs for the premises (i.e., quantity and type) should be determined by a compost SME and will depend on site-specific (typically poultry house-specific) conditions and circumstances.*

### SUITABLE CARBON SOURCES

- Wood chips about 2" or less in size
- Wood shavings
- Yard/brush trimmings 2" or less in size
- Partially composted leaf and yard waste (still hot)
- Sawdust (not used alone)
- Chopped hay/straw
- Chopped corn stover
- Oat/sunflower hulls
- Ground pallets (2" or less) if fasteners have been removed
- Other material listed in APHIS *Composting Protocol* or as recommended by APHIS-recognized SME and approved for use on agricultural land by the state

Mulch from yard trimmings/waste



Wood chips



Chopped corn stover



Oat hulls



### NOT SUITABLE WITHIN A CARBON SOURCE

- Rocks
- Glass
- Plastic
- Large logs/branches
- Grass clippings >15%
- Ground construction & demolition debris (CDD)
- Regulated pests (emerald ash borer, etc.)
- Rubber
- Metal/baling wire
- Chemicals
- Concrete
- Painted/pressure treated wood
- Soil/sand >15% by volume
- Carbon source with free liquid or excessive leachate

Wood chips with rocks/gravel



Construction demolition debris



Mixed wood with logs/large lumber pieces



# Characteristics of Raw Materials<sup>1</sup>

Material	Type of value	% N (dry weight)	C:N ratio (weight to weight)	Moisture content % (wet weight)	Bulk density (lbs per cubic yard)
----------	---------------	---------------------	---------------------------------	------------------------------------	--------------------------------------

## CROP RESIDUES AND FRUIT/VEGETABLE-PROCESSING WASTE

Apple filter cake	Typical	1.2	13	60	1,197
Apple filter cake	Typical	1.2	13	60	1,197
Apple pomace	Typical	1.1	48	88	1,559
Apple-processing sludge	Typical	2.8	7	59	1,411
Cocoa shells	Typical	2.3	22	8	798
Coffee grounds	Typical	—	20	—	—
Corn cobs	Range	0.4-0.8	56-123	9-18	—
	Average	0.6	98	15	557
Corn stalks	Typical	0.6-0.8	60-73 <sup>a</sup>	12	32
Cottonseed meal	Typical	7.7	7	—	—
Cranberry filter cake	Typical	2.8	31	50	1,021
(with rice hulls)	Typical	1.2	42	71	1,298
Cranberry plant (stems, leaves)	Typical	0.9	61	61	—
Cull potatoes	Typical	—	18	78	1,540
Fruit wastes	Range	0.9-2.6	20-49	62-88	—
	Average	1.4	40	80	—
Olive husks	Typical	1.2-1.5	30-35	8-10	—
Potato-processing sludge	Typical	—	28	75	1,570
Potato tops	Typical	1.5	25	—	—
Rice hulls	Range	0-0.4	113-1120	7-12	185-219
	Average	0.3	121	14	202
Soybean meal	Typical	7.2-7.6	4-6	—	—
Tomato-processing waste	Typical	4.5	11 <sup>a</sup>	62	—
Vegetable produce	Typical	2.7	19	87	1,585
Vegetable wastes	Typical	2.5-4	11-13	—	—

## FISH AND MEAT PROCESSING

Blood wastes (slaughterhouse waste and dried blood)	Typical	13-14	3-3.5	10-78	—
Crab and lobster wastes	Range	4.6-8.2	4.0-5.4	35-61	—
	Average	6.1	4.9	47	240
Fish-breeding crumbs	Typical	2.0	28	10	—
Fish-processing sludge	Typical	6.8	5.2	94	—
Fish wastes (gurry, racks, and so on)	Range	6.5-14.2	2.6-5.0	50-81	—
	Average	10.6	3.6	76	—
Mixed slaughterhouse waste	Typical	7-10	2-4	—	—
Mussel wastes	Typical	3.6	2.2	63	—
Poultry carcasses	Typical	2.4 <sup>b</sup>	5	65	—
Paunch manure	Typical	1.8	20-30	80-85	1,460
Shrimp wastes	Typical	9.5	3.4	78	—

<b>Material</b>	<b>Type of value</b>	<b>% N</b> (dry weight)	<b>C:N ratio</b> (weight to weight)	<b>Moisture content %</b> (wet weight)	<b>Bulk density</b> (lbs per cubic yard)
-----------------	----------------------	----------------------------	--	---	---

**MANURES**

Broiler litter	Range	1.6-3.9	12-15 <sup>a</sup>	22-46	756-1,026
	Average	2.7	14 <sup>a</sup>	37	864
Cattle	Range	1.5-4.2	11-30	67-87	1,323-1,674
	Average	2.4	19	81	1,458
Dairy tie stall	Typical	2.7	18	79	—
Dairy free stall	Typical	3.7	13	83	—
Horse-general	Range	1.4-2.3	22-50	59-79	1,215-1,620
	Average	1.6	30	72	1,379
Horse-race track	Range	0.8-1.7	29-56	52-67	—
	Average	1.2	41	63	—
Laying hens	Range	4-10	3-10	62-75	1,377-1,620
	Average	8.0	6	69	1,479
Sheep	Range	1.3-3.9	13-20	60-75	—
	Average	2.7	16	69	—
Swine	Range	1.9-4.3	9-19	65-91	—
	Average	3.1	14	80	—
Turkey litter	Average	2.6	16 a	26	783

**MUNICIPAL WASTES**

Garbage (food waste)	Typical	1.9-2.9	14-16	69	—
Night soil	Typical	5.5-6.5	6-10	—	—
Paper from domestic refuse	Typical	0.2-0.25	127-178	18-20	—
Pharmaceutical wastes	Typical	2.6	19	—	—
Refuse (mixed food, paper, etc.)	Typical	0.6-1.3	34-80	—	—
Sewage sludge	Range	2-6.9	5-16	72-84	1,075-1,750
Activated sludge	Typical	5.6	6	—	—
Digested sludge	Typical	1.9	16	—	—

**STRAW, HAY, SILAGE**

Corn silage	Typical	1.2-1.4	38-43 <sup>a</sup>	65-68	—
Hay-general	Range	0.7-3.6	15-32	8-10	—
	Average	2.10	—	—	—
Hay-legume	Range	1.8-3.6	15-19	—	—
	Average	2.5	16	—	—
Hay-non-legume	Range	0.7-2.5	—	—	—
	Average	1.3	32	—	—
Straw-general	Range	0.3-1.1	48-150	4-27	58-378
	Average	0.7	80	12	227
Straw-oat	Range	0.6-1.1	48-98	—	—
	Average	0.9	60	—	—
Straw-wheat	Range	0.3-0.5	100-150	—	—
	Average	0.4	127	—	—

<b>Material</b>	<b>Type of value</b>	<b>% N</b> (dry weight)	<b>C:N ratio</b> (weight to weight)	<b>Moisture content %</b> (wet weight)	<b>Bulk density</b> (lbs per cubic yard)
<b>WOOD AND PAPER</b>					
Bark-hardwoods	Range	0.10-0.41	116-436	—	—
	Average	0.241	223	—	—
Bark-softwoods	Range	0.04-0.39	131-1,285	—	—
	Average	0.14	496	—	—
Corrugated cardboard	Typical	0.10	563	8	259
Lumbermill waste	Typical	0.13	170	—	—
Newsprint	Typical	0.06-0.14	398-852	3-8	195-242
Paper fiber sludge	Typical	—	250	66	1140
Paper mill sludge	Typical	0.56	54	81	—
Paper pulp	Typical	0.59	90	82	1403
Sawdust	Range	0.06-0.8	200-750	19-65	350-450
	Average	0.24	442	39	410
Telephone books	Typical	0.7	772	6	250
Wood chips	Typical	—	—	—	445-620
Wood-hardwoods (chips, shavings, and so on)	Range	0.06-0.11	451-819	—	—
	Average	0.09	560	—	—
Wood-softwoods (chips, shavings, and so on)	Range	0.04-0.23	212-1,313	—	—
	Average	0.09	641	—	—
<b>YARD WASTES AND OTHER VEGETATION</b>					
Grass clippings	Range	2.0-6.0	9-25	—	—
	Average	3.4	17	82	—
Loose	Typical	—	—	—	300-400
Compacted	Typical	—	—	—	500-800
Leaves	Range	0.5-1.3	40-80	—	—
	Average	0.9	54	38	—
Loose and dry	Typical	—	—	—	100-300
Compacted and moist	Typical	—	—	—	400-500
Seaweed	Range	1.2-3.0	5-27	—	—
	Average	1.9	17	53	—
Shrub trimmings	Typical	1.0	53	15	429
Tree trimmings	Typical	3.1	16	70	1,296
Water hyacinth-fresh	Typical	—	20-30	93	405

1 Reprinted with permission from the Cornell Waste Management Institute.

a Estimated from ash or volatile solids data.

b Mostly organic nitrogen.



## Standard Operating Procedures: Open-Air Burning



*Note: Open-air burning is often not used due to environmental and public concerns.*

This method involves burning on open land and above ground in a pit, pyres, air curtain or mobile incineration units. Open-air burning on ground or in a pit is not a preferred method due to the potential of unsightly smoke, potential to diminish air quality, and effectiveness. Engineered mobile incineration units have successfully been used for foreign animal diseases (FADs) in Europe and other countries. The mobile units are self-controlled systems that use diesel fuel to support combustion. No other planning requirements are required other than contacting the State environmental agency and following local guidance for notification, reporting and/or permitting if required.

### PLANNING

1. Obtain approval from State environmental agency.
2. Calculate the amount of material required to accomplish the open-air burning. One adult bovine carcass is equivalent to five finishing pigs or five adult sheep. One adult bovine carcass will require:<sup>1</sup>
  - a. 3 bales of straw or hay,
  - b. 3 pieces of untreated heavy lumber,
  - c. 50 pounds of kindling wood,
  - d. 100 pounds of coal pieces that are 6–8 inches in diameter, and
  - e. 1 gallon of liquid fuel. Do not use gasoline. The type and amount of fuel used for incineration will be influenced by local fuel availability and conditions. For effective burning, fuel should be as dry as possible.
3. Other equipment includes mechanical chains and lifting equipment. Identify personnel properly trained in the use of this equipment. Fire safety equipment also should be readily available.
4. Build a fire bed that is perpendicular to the prevailing wind.

### OPERATIONS

1. Don all required personal protective equipment (PPE) detailed in the Site-Specific Health and Safety/PPE Plan.
2. Prepare the bed:
  - a. Stake out and fence the selected burning site for the fire-bed construction.
  - b. Allow a firebed-length of 3 feet for each adult cattle carcass, five swine carcasses, or five sheep carcasses. The team may find it helpful to convert the number of carcasses in need of disposal into bovine-equivalent carcasses as seen in Table 14.F-1.<sup>2</sup>

<sup>1</sup> Recommended incineration materials include straw or hay, untreated heavy timber, kindling wood, coal, and liquid fuel.

<sup>2</sup> To estimate the number of bovine-equivalent carcasses, first list the number and species of carcasses to be incinerated, then convert these figures into a number representing bovine-equivalent carcasses.

**Table 14.F-1. Estimating Bovine—Equivalent Carcasses**

Animal	Bovine Equivalent Carcasses
1 adult cow or bull	1 bovine-equivalent carcass
5 adult swine	1 bovine-equivalent carcass
5 adult sheep	1 bovine-equivalent carcass

- c. Lay three rectangular rows of straw or hay bales lengthwise along the line of the fire bed. Rows should be 12 inches apart and each bale should be separated by a 12-inch gap.
  - d. Place loose straw in the spaces between the rows and bales to provide natural air flow.
  - e. Place large pieces of lumber lengthwise on top of each row. Distribute large- and medium-sized pieces of lumber across the fire bed, leaving 6 to 12 inches of space between them.
  - f. Place small kindling wood on the fire bed and cover loosely with straw.
  - g. Spread 6- to 8-inch-diameter coal evenly at the rate of 500 pounds per square yard, or use a liquid fuel such as diesel or furnace oil over the wood mixture to make a level bed.
  - h. Lay the carcasses on the fire bed.
  - i. Position carcasses on their backs with their feet in the air and alternately head to tail.
  - j. Two goats, sheep, or swine carcasses can be placed on top of each bovine carcass and burned without additional fuel.
  - k. Place loose straw on top of the carcasses and all spaces in between.
  - l. Spray liquid fuel over the fire bed with a pump, or use sprinkling cans or buckets.
  - m. Soak rags in kerosene oil or waste oil and place them every 30 feet along the fire bed for a better and more harmonized ignition.
  - n. Make sure that people and equipment are at least 25 feet from the burning pile.
  - o. Have fire equipment readily available.
  - p. Ignite the fire bed.
  - q. Occasionally stir the burning pile with front-end loaders.
  - r. Add more fuel as needed.
  - s. Bury the ash after all carcasses have been burned completely and the fire has been extinguished.
3. Thoroughly clean and disinfect all disposal equipment. See the Cleaning and Disinfection SOP: [go.usdatraining.com/SOP\\_CD](http://go.usdatraining.com/SOP_CD) and the Biosecurity SOP: [go.usdatraining.com/SOP\\_Biosecurity](http://go.usdatraining.com/SOP_Biosecurity).

## Appendix A: Carcass Management: Open-Air Burning Checklist

---

- Will local and State agencies allow open burning at the site?
  - Local Fire Department
  - State Department of Agriculture, Animal Health
  - State Department of Environment or Natural Resources
  - USDA-APHIS
  - USEPA
- Will open burning release air pollutants in compliance with public health standards?
- If so, can the permit conditions, such as measures to control the spread of fire, distance to occupied buildings etc. be met?
  - What environmental testing (e.g., water, ash, soils) are required and at what frequency?
  - How and where will the ash be disposed of?
  - Are weather conditions (e.g., wind and drought) suitable for open are burning?
- If so, will burning be publically acceptable?
- If so, have you arranged for the necessary personnel, equipment and supplies to be delivered to the site?
  - Adequate source of combustible material and fuel to keep the fire going. Verify that type of fuel is acceptable to regulatory agencies.
  - Other equipment including mechanical chains and lifting equipment.
  - Personnel properly trained in the use of this equipment.
  - Fire safety equipment also should be readily available.
- If open-air burning is an option, see *Open-Air Burning* training module at [go.usdatraining.com/open\\_burning](https://go.usdatraining.com/open_burning) and implement on-site open air burning. If not, continue to the next option.

## Executive Summary

On-site un-lined burial is the practice of placing the carcasses in deep pits or trenches (6 feet or more in depth). In this approach, the carcasses are placed on the natural soil in the bottom of the trench and then covered with the soil that has been excavated. No carbonaceous material is added and no impermeable liner is provided.

Carcasses disposed by deep burial decompose slowly, meaning that burial sites must be taken out of normal use and may be restricted from future land use activities such as building construction.

Sites for deep burial should be carefully evaluated prior to choosing this disposal method. The checklist in [Appendix A](#) may be used when evaluating this approach to carcass disposal.

## Burial Effect on Environment

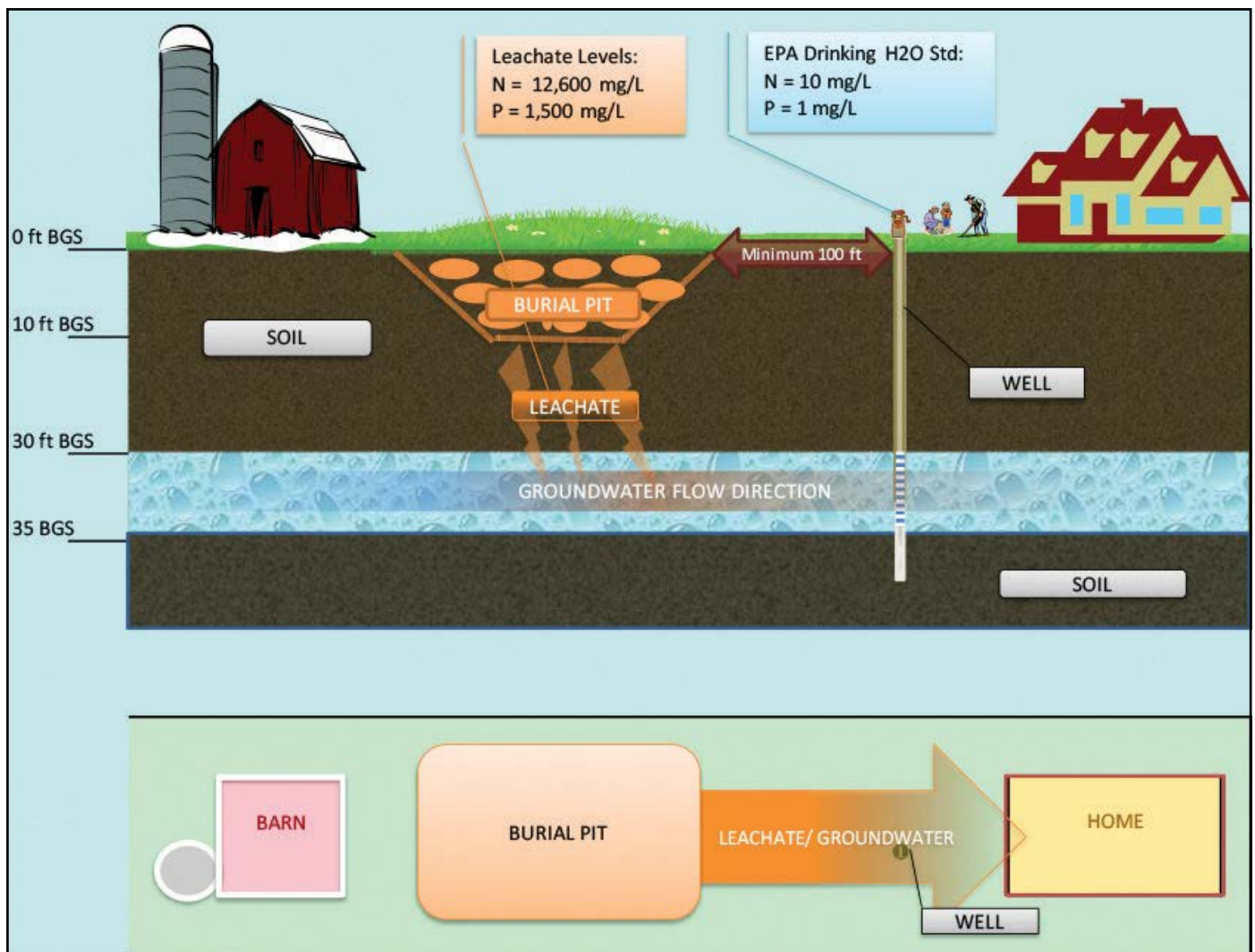

Figure 1. Impact of burial on groundwater

## Why is nitrogen a problem?

- EPA standard for nitrates in drinking water is 10.0 mg/L
- Carcass burial sites generate over 1000 times the standard
- Causes methemoglobinemia (blue baby syndrome) which can be fatal to infants
- Toxic to aquatic life
- Depletes dissolved oxygen in receiving waters
- Stimulates aquatic plant growth (eutrophication)

## Standard Operating Procedures: Un-Lined Burial<sup>1</sup>

### PLANNING

1. Review State and local regulations regarding burial. Individual States regulate the parameters for burial (e.g., quantity of carcasses; depth to water table, and distance to wells, and surface water; and property lines).
2. Obtain information from the USDA NRCS Web Soil Survey such as soil maps, drainage, and seasonal water table data.
3. If the Web Soil Survey data indicates the site is suitable for carcass burial, obtain the services of a qualified environmental professional such as a professional geologist or professional engineer to collect at least three soil borings of the site to the water table. Trench burial has the potential to impact groundwater and generate offensive odors, requiring a deep water table and impermeable soil. Using the soil logs, perform hydrogeological and contaminant transport modeling to assess the likelihood of the burial site contaminating drinking water aquifers.
4. Consult with appropriate State regulatory agencies about permits for potential sites before initiating operations.
5. Verify the site is large enough for on-site burial of the carcasses based on [Appendix B Land Area or Excavation Volume Required for Trench Burial](#), and the FAD/PReP Guidelines: Disposal. ([go.usdatraining.com/SOP\\_disposal](http://go.usdatraining.com/SOP_disposal)).
6. Verify the site is accessible to carcass-hauling trucks and heavy equipment.
7. Design the excavation size, depth, and side slope angles to prevent cave-ins.
8. Prepare and maintain a list of names and contact information for heavy machinery operators, fire department personnel, law enforcement, public works departments, departments of transportation, and regulatory agencies.
9. Contract with local heavy equipment suppliers and operators to deliver, operate, fuel, and maintain necessary heavy equipment. Contract for carcass storage equipment and/or services if needed.
10. Ensure that personnel who will be operating the heavy equipment are properly certified in the use of the equipment.
11. Train disposal personnel on safety, biosecurity, and operational procedures in accordance with the Site-Specific Disposal Plan.

<sup>1</sup> Mukhtar, S., Boadu, F.O., Jim, Y.H., Shim, W., Vestal, T.A., & Wilson, C.L. (2012). *Managing Contaminated Animal and Plant Materials: Field Guide on Best Practices*.

## OPERATIONS

1. Obtain all appropriate permits and approvals, including landowner's permission and acceptance of long-term environmental liability, to begin burial.
2. Don all required personal protective equipment (PPE) as detailed in the Site-Specific Health and Safety/PPE Plan.
3. Fence and stake the burial site.
4. Obtain the heavy equipment and machinery (backhoe, scraper, bulldozer, or other equipment) required for excavating.
5. Excavate the appropriately-sized trench based on the excavation design parameters.
6. Puncture/vent the carcasses by stabbing the area posterior to the ribs and the thoracic and abdominal cavities, on the left side for ruminants.
7. Place carcasses in the trench.
8. Cover the carcasses with the excavated earth; grade the surface soil to facilitate runoff.
9. Seed the surface of the excavated area to minimize soil erosion.
10. Thoroughly clean and disinfect all of the disposal equipment. See the Cleaning and Disinfection SOP: [go.usdatraining.com/SOP\\_CD](http://go.usdatraining.com/SOP_CD) and the Biosecurity SOP: [go.usdatraining.com/SOP\\_Biosecurity](http://go.usdatraining.com/SOP_Biosecurity).
11. Regularly inspect and maintain the site by adding additional backfill to prevent pooling of water if necessary.
12. Highly recommended: monitor groundwater quality down gradient of the burial site(s) to ensure the ongoing safety of ground water.

### *Note on Mass Burial*

Mass burial involves collecting carcasses from multiple affected premises and placing them in a large burial unit. The disposal unit must meet the criteria for a Subtitle D landfill, including leachate and landfill gas collection and management systems. During the 2001 foot-and-mouth disease (FMD) outbreak in the UK, approximately 20 percent (1.3 million carcasses) of FMD-infected carcasses were disposed using mass burial. Siting, permitting, designing, and constructing a Subtitle D landfill requires extensive site assessment, professional engineering design, and rigorous quality control during construction. The process takes a significant amount of time and funds, and the closed disposal unit requires long-term monitoring and acceptance of future environmental liability by the property owner. It is likely more cost-effective and efficient to establish an agreement with an existing Subtitle D landfill than to site, permit, design, and build a new one in the face of an emergency.

## Appendix A: Carcass Management On-Site Burial Checklist

---

- Will state environmental agency permit burial at the site?
  - Consider soil suitability (see USDA NRCS online Web Soil Survey at [go.usdatraining.com/WSS](http://go.usdatraining.com/WSS) based on guidance from state environmental officials?)
  - Obtain written approval from State environmental authority that burial is permitted.
  - Consider potential for leachate to contaminate groundwater.
  - Consider all groundwater pathways including the presence of drain tiles, soil characteristics, depth to groundwater, use of groundwater, etc.
  - Consider potential for the burial site to create a stability or explosion hazard in nearby structures from production of methane.
  
- If so, is adequate land available for on-site burial? (Assume 1.42 acres per 1000 half-ton cows, 0.28 acres per 1000 swine or sheep, and 0.01 acres per 1000 poultry or use the Options Time and Cost Calculator at [go.usdatraining.com/disposal\\_tools](http://go.usdatraining.com/disposal_tools).)
  
- If so, will land owner accept on-site burial, associated environmental liabilities, and potential loss of property value or use?
  
- If on-site burial is an option, see the *On-Site Burial* training module at [go.usdatraining.com/burial\\_module](http://go.usdatraining.com/burial_module) and implement on-site burial. If not, continue to the next option.

## Appendix B: Land Area or Excavation Volume Required for Trench Burial

Jurisdiction/ Source	Total Trench Depth (D)	Carcass Depth	Depth Cover	Trench Width (W)	Trench Length (L)	Est. Area or Volume Required	Carcass Equivalents	Other Notes
<b>Literature</b>								
NC (Wineland & Carter, 1997)						50-55 ft <sup>3</sup> (~2.0 yd <sup>3</sup> ) per 1,000 broilers or commercial layers 100 ft <sup>3</sup> (3.7 yd <sup>3</sup> ) per 1,000 turkeys		Note that the volume estimates were based on a disposal pit design, rather than trench burial.
Australia (Atkins & Brightling, 1985)	~3.5 m (11.5 ft)	1.5 m (5 ft)	2.0 m (6.5 ft) to ground level	3-5 m (10-16.5 ft) determined by equipment used	--	1 m <sup>3</sup> (~35 ft <sup>3</sup> or 1.3 yd <sup>3</sup> ) per 8-10 mature sheep (off-shears)	--	To calculate the necessary pit volume, including an allowance for cover, a value of 0.3 m <sup>3</sup> of excavation per sheep was used.
Australia (Lund, Kruger, & Weldon)	2.6 m (8.5 ft)	--	1 m (3.3 ft)	4 m (13 ft)	6.7 km (~4.2 mi) for 30,000 cattle	30,000 head of cattle requires trench of 70,000 m <sup>3</sup> (2.5 million ft <sup>3</sup> , or 92,000 yd <sup>3</sup> )	--	Equates to excavation volume of 2.3 m <sup>3</sup> (82 ft <sup>3</sup> or 3 yd <sup>3</sup> ) per cattle carcass.
N/A (McDaniel, 1991)	9 ft	3 ft	6 ft	7 ft	--	14 ft <sup>2</sup> at bottom of pit for each adult bovine (assuming 3 ft depth, equates to ~42 ft <sup>3</sup> or ~1.2 yd <sup>3</sup> per adult bovine)	1 adult bovine = 5 mature sheep or hogs	For every additional 3 ft of trench depth, the number of carcasses per 14 ft <sup>2</sup> can be doubled. Due to bulky feathers, poultry require more burial space per unit of weight than cattle, hogs, or sheep. Estimate space required for poultry by counting carcasses that fill a space of known volume (i.e. truck).
N/A (Sander, Warbington, & Myers, 2002)	9 ft	--	3-4 ft	7 ft	--	14 ft <sup>2</sup> per mature cow	--	
N/A (Anonymous, 1973)	--	--	--	--	--	Assume 40 lbs of poultry carcasses per 1 ft <sup>3</sup>	--	Equates to approximately 1,080 lbs/yd <sup>3</sup> .



**ON-SITE UN-LINED BURIAL**

Jurisdiction/ Source	Total Trench Depth (D)	Carcass Depth	Depth Cover	Trench Width (W)	Trench Length (L)	Est. Area or Volume Required	Carcass Equivalents	Other Notes
<b>Regulatory Agencies</b>								
AL (USDA, Natural Resource Conservation Service, Alabama)	8 ft (for deep soils where bedrock not a concern)	1 ft max small animals 1 carcass max large animals	2 ft mounded	--	--	--	--	Max size of burial excavation should be 0.1 acre (~4,400 ft <sup>2</sup> ) Excavations over 3.5 ft deep should be sloped on sides at least 1.5 (horiz) to 1 (vert)
TX (USDA, Natural Resources Conservation Service, Texas, 2002)	3 ft min 8 ft max	1 ft small animals 1 carcass large animals	2 ft	4 ft	Adequate for mortality	Total mortality weight ÷ 62.4 lb/ft <sup>3</sup> = ~volume of mortality in ft <sup>3</sup> Pit excavation = 2-4 times the mortality volume to allow for voids and fill soil Spreadsheet avail on request	--	Pits 6 ft or greater in depth – perform soil tests to a depth two ft below lowest planned excavation Multiple pits – separate by 3 ft of undisturbed or compacted soil For deep soils, carcasses and soil can be placed in multiple layers up to a total depth of 8 ft 62.4 lb/ft <sup>3</sup> suggests a density of approximately 1,680 lbs/yd <sup>3</sup>
APHIS (USDA, 1980)	9 ft or Greater	--	--	7 ft or greater	--	14 ft <sup>2</sup> at bottom of pit for each adult bovine	1 adult bovine = 5 mature sheep or hogs	For every additional 3 ft of trench depth, the number of carcasses per 14 ft <sup>2</sup> can be doubled. Trench site should be mounded over and neatly graded. Do not pack the trench – decomposition and gas formation will crack a tightly packed trench causing it to bubble and leak fluids.
APHIS (USDA, 2001a)	--	--	--	--	--	42 ft <sup>3</sup> (~1.2 yd <sup>3</sup> ) required to bury 1 bovine, 5 pigs, or 5 sheep	--	
Australia (Agriculture and Resource Management Council of Australia and New Zealand, 1996)	~5 m (~16.5 ft)	--	2 m (6.5 ft)	~3 m (~10 ft)	--	1.5 m <sup>3</sup> (~53 ft <sup>3</sup> or ~2 yd <sup>3</sup> ) per each adult beast or 5 adult sheep	--	Example: Trench 5 m deep x 3 m wide filled with carcasses to within 2.5 m of ground level will accommodate 5 cattle or 25 sheep per linear meter (2.5 x 3 x 1 = 7.5 m <sup>3</sup> ; 7.5/1.5 = 5 cattle or 25 sheep)
Alberta, Canada (Ollis, 2002)	4-5 m (13-16.5 ft)	--	2 m (6.5 ft)	2 m (6.5 ft)	10 m (33 ft)	31 adult cattle carcasses require trench 4 x 2 x 10 m (DxWxL) (80m <sup>3</sup> , 2,800 ft <sup>3</sup> , or 105 yd <sup>3</sup> per 31 adult cattle) (~2.6 m <sup>3</sup> , 92 ft <sup>3</sup> , or 3.5 yd <sup>3</sup> per carcass) 46 adult cattle carcasses require trench 5 x 2 x 10 m (DxWxL)	1 bovine = 5 adult hogs or sheep 1 bovine = 40 broiler chickens (market-ready weight)	

## Executive Summary



*Note: Mobile incineration technology is currently being pursued. This section will be updated when the process for permitting and implementation has been completed.*

Mobile treatment refers to a range of technologies for degrading or processing carcasses to eliminate pathogens and reduce volumes. Some are designed to destroy the infected tissues while others are meant to create a useful product at the end of the process. In general, the advantage of these technologies is that they may be done anywhere, thus reducing the need to move infected carcasses off of the farm. The primary disadvantages are availability and relatively low throughput. The one technology that has seen use in emergency events is air-curtain burners. This section includes details on operating air-curtain burners.

## Overview of Mobile Treatment Technologies

Mobile treatment technologies can offer alternative, innovative, and immediate approaches to disposing of animal carcasses on-site, particularly in response to emergency situations. Several types are defined below:

### INCINERATION

#### **Air-curtain incineration**

Blowing high velocity air across and down at an optimum angle into a firebox pit, creating an air-curtain on top and a rotational turbulence within the firebox.

#### **Two Stage Incineration**

The waste mass is destroyed in multiple chambers a primary (combustion) chamber followed by a secondary (gasification) chamber.

### RENDERING

The process of converting animal carcasses into carcass meal (protein-based solids), melted fat or tallow, and water.

### ALKALINE HYDROLYSIS

Involves processing carcasses at high temperature, high pressure, and high pH to convert the proteins, nucleic acids, and lipids of the tissues to a sterile aqueous solution and solid by-products.

### STEAM OR MICROWAVE STERILIZATION

Uses the direct application of steam or multiple, high-energy microwave generators to treat the disposal waste.

### ADVANTAGES

- Easy to implement due to portability of units.
- Inactivates pathogens.
- Reduces the risk of disease spread due to limited movement and limited handling of infected material.
- Environmentally favorable.
- Self-contained units are generally acceptable to the public.

## DISADVANTAGES

- Availability of resources and equipment may be limited.
- Accessibility to equipment may be impeded depending on vendor proximity to the on-site location.
- May need specially skilled operators who can keep equipment running and who are trained in biosafety and biosecurity.
- Level, paved areas may be needed to set up equipment and stage materials.
- Availability and/or sources of spare parts for back-up equipment may be limited.
- Extensive utilities may be required, such as fuel and electric, for operations and support equipment.
- Some methods may be limited by the volume of carcasses they can accommodate.
- Some technologies may require preprocessing of carcasses and disposal of byproducts.

### *Emergency Event Usage*

Of the different types of mobile treatment systems available, only the air-curtain burners have been used in emergency events at the time of this writing, so the remainder of this document will focus on that technology. As other mobile treatment systems are developed and approved for emergency event usage, descriptions of those technologies will be added.

## Standard Operating Procedures: Air-Curtain Incineration

---

### PLANNING

1. Consult with appropriate State regulatory agencies for air quality and solid waste permits before initiating operations.
2. Inform any other local authorities about the planned thermal destruction as required.
3. Ensure that equipment and spare parts are available for the chosen thermal method.
4. Ensure enough trained personnel are available to maintain continuous operations.
5. Provide appropriate sustenance and housing needs for disposal personnel if necessary.
6. Assuming a mobile air-curtain incinerator will be brought to the affected premises, verify the availability of air-curtain incineration units and carcass storage facilities such as refrigerated rooms, transport vehicles, freezers, or other means of carcass preservation.
7. Consult with USDA NRCS and evaluate the affected premises for the depth to the water table and proper soil conditions if trench burners will be used.
8. Use refractory boxes on sites with a high water table or on rocky soil and where trenches would be difficult or costly to build.

9. Locate the mobile air-curtain unit in an area that is easily accessible to heavy vehicles hauling carcasses and equipment.
10. Gather the appropriate materials such as solid fuels (straw, hay, coal, kindling wood, untreated lumber). Base the amount of solid fuels to use on the amount of moisture in the wood or other organic sources (hay, grain, stalks, and straw) and the fat and moisture content of the carcasses. Use a fuel-to-carcass weight ratio ranging from 1:1 to 2:1. Ensure availability of enough fuel to last 2-3 days or the length of time needed to maintain uninterrupted supply.

## OPERATIONS

1. Don all required personal protective equipment (PPE) as detailed in the Site-Specific Health and Safety/PPE Plan.
2. Build the appropriate-sized trench based on equipment vendor recommendations, or use refractory boxes. See NAHEMS Guidelines: Disposal.
3. Monitor the wind direction before and during the burning operations.
4. Keep workers out of the path of the flame.
5. Handle the ash in the refractory boxes carefully and dispose of it at a burial or land application site that has been approved by the appropriate regulatory agency.
6. If a large number of animal carcasses (exceeding a cumulative weight of 1 million pounds) require destruction, conduct the thermal destruction at a distance of 2 miles from residential buildings, roads, and utilities.
7. Use proper precautions when dealing with certain foreign animal diseases (FADs) such as HPAI to prevent personnel inhalation of airborne pathogens. Personnel must use proper PPE. See the NAHEMS Guidelines: Health and Safety, NAHEMS Guidelines: PPE, and disease specific Health and Safety/PPE SOPs for more information.
8. Thoroughly clean and disinfect all of the disposal equipment. See the C&D and Biosecurity SOPs.

## Appendix A: Carcass Management: Mobile Treatment Checklist

---

- Contact all appropriate mobile treatment technology vendors including the USDA Veterinary Stockpile through the Incident Command Team Logistics Branch.
  - Verify the units are available for deployment to your site.
  - Verify your ability to meet all site/utility requirements.
  - Verify units can be fully disinfected after use.
  - Verify the units have adequate capacity to meet your needs.
  - If the capacity is less than needed, can the carcasses be stored/refrigerated while awaiting disposal?
  - Verify the availability of skilled operators and spare parts to keep the units operational.
  - Verify the unit can be set up on the site (e.g., the site has appropriate grading and stable surface to support the weight of the unit).
- If so, is the technology permitted by the State environmental agency?
- If so, can the permit conditions be met?
- If so, can the process byproducts be readily disposed?
- If mobile treatment is an option, see *Mobile Technologies* training module at [go.usdatraining.com/mobile\\_module](https://go.usdatraining.com/mobile_module) and implement. If not, continue to the next option.

## Carcass Management: Off-Site Permitted Landfill Checklist

- Consult with state environmental agency for landfill advice.
- Access a comprehensive list of landfills using the I-WASTE Tool at [go.usdatraining.com/I-WASTE](https://go.usdatraining.com/I-WASTE) or use the Carcass Management Dashboard at [go.usdatraining.com/Disposal](https://go.usdatraining.com/Disposal).
  - Access the [I-WASTE tool website](#).
  - Choose treatment and disposal facilities button.
  - Enter filter criteria such as “facility type” (e.g., rendering, incinerators, or landfill).
  - Note that construction debris landfills are not suitable for carcass disposal, and hazardous waste landfills are not necessary unless the carcasses are contaminated with a hazardous material causing them to be classified as hazardous.
  - Enter State or EPA region, and click “View List of Facilities” button.
- Contact facilities and determine if they will accept your livestock or poultry and meet some or all of your capacity needs.
  - If there is insufficient capacity, consider fast-tracking expansion of existing landfill or permitting of new landfill for this purpose.
  - Consider potential environmental and biosecurity concerns.
  - Verify landfill has no outstanding permit violations.
  - Procure landfill services through appropriate Incident Management Team branch.
- If the landfill will accept the material, arrange for biosecure transport.
  - Obtain controlled movement permit for transport of infected carcasses
  - Determine type of transport vehicles required. If the waste must travel on public roads, it should be transported in closed, leak-resistant trucks or dumpsters. Secondary containment may be needed, depending on the type of waste being transported. See [Landfill Disposal Guidance](#).
  - Work with Depopulation Group Supervisor within the Incident Command System to determine how many animals can be depopulated per day and how many trucks will be needed for transport per day, ensuring the rates are about the same. If not, arrange for covered, leak-resistant storage.
  - Pre-identify transport routes to off-site permitted landfill(s) to minimize exposure to susceptible premises.
- If permitted landfilling is an option, see the *Secure Transport* and *Off-Site Treatment/Burial* training modules at [go.usdatraining.com/Disposal\\_training](https://go.usdatraining.com/Disposal_training) and implement off-site permitted landfilling. If not, continue to the next option.

# Landfill Disposal Guidance— Recommended Waste Acceptance Practices for Landfills

December 29, 2022

---

## BACKGROUND

Highly pathogenic avian influenza (HPAI), commonly known as bird flu, is a severe disease of poultry caused by certain strains of influenza A virus. These viruses are found naturally in wild bird populations, and waterfowl can carry HPAI viruses without showing signs of illness. Wild birds can serve as a source of HPAI virus infection for domestic poultry, resulting in an outbreak. The USDA is the lead federal agency in responding to foreign animal diseases, such as HPAI.

## PURPOSE

The intent of this guidance is to provide recommended waste acceptance practices for landfill disposal of carcasses of HPAI affected birds and other materials contaminated with the virus. In an outbreak, responders must dispose of all carcasses and other contaminated materials in a timely, biosecure, and environmentally responsible manner to prevent the spread of the virus to other poultry farms. Contaminated material should stay on the infected premises whenever possible. The use of permitted landfills may be an option for disposal of infected material that cannot be disposed of on the premises. Operators of these landfills must manage carcasses according to necessary environmental controls. In addition, landfill workers and outbreak responders must follow strict biosecurity procedures during transportation and disposal of contaminated materials.

## PROTECTION OF LANDFILL OPERATORS

While the Centers for Disease Control and Prevention (CDC) has determined that risk for human infection from previous U.S. HPAI outbreak strains is low (see the *CDC Interim Guidance for Landfill Workers in the United States Disposing of Poultry Carcasses During Outbreaks of HPAI*), the CDC recommends landfill operators to protect workers involved in disposal operations to mitigate exposure to HPAI virus. Landfill operators disposing of HPAI contaminated materials should follow CDC's guidelines, which are available [here](#) or by visiting [www.aphis.usda.gov/fadprep](http://www.aphis.usda.gov/fadprep).

## GENERAL LANDFILLING PROCESS

Personnel from USDA or State Departments of Agriculture will supervise all landfill operations disposing of HPAI contaminated materials.

The landfill operator will determine the number of carcasses and other materials and frequency of deliveries they will accept from an HPAI affected premises. The incident management team may require disposal of a variety of contaminated materials, including manure, eggs, litter, feed, egg packaging, pallets, used personal protective equipment, and decontamination supplies.

Landfill management, State or Federal site managers and/or case managers for an HPAI affected

premises, and the USDA APHIS contracting officer will communicate to determine the scope of work. Landfill operators and the State or Federal site manager for an affected premises will coordinate deliveries of contaminated material to the landfill in advance.

## REQUESTING REIMBURSEMENT OF LANDFILL COSTS

The National Incident Management Coordinator (NIC) must approve landfilling as a disposal method for HPAI contaminated materials **in writing prior to** transport of materials off an affected premises. Parties responsible for disposal activities on an HPAI affected premises must provide detailed cost estimates for labor, equipment, supplies, and fees associated with the landfill disposal process to the NIC as part of the request for approval.

## LANDFILL REIMBURSEMENT

For landfills to be reimbursed by USDA APHIS for any HPAI-related disposal costs, USDA APHIS must approve costs in advance.. Producers should consult with their USDA APHIS reimbursement specialist regarding reimbursement at the time of an outbreak prior to any expenditures. Producers may choose to contract directly with landfills.

Contractors can be hired through the USDA to provide roll offs and other equipment at farms, commercial truck drivers (to transport roll offs to and from landfills), and personnel to perform cleaning and disinfection (C&D) of all conveyances. Costs associated with the landfill may also be included in State emergency agreements.

*Any entity receiving payment from USDA must register in SAM.gov to be paid.*

## GUIDELINES FOR STATE REGULATORS

State environmental protection or natural resources agencies typically determine the guidelines for containment liners, leachate management, grey water management, timelines for covering contaminated materials, the depth of covering, modifications to working faces, and permits for landfill burial. The USDA can provide suggestions and brief the landfill regulatory agencies, but ultimately it is the landfill's responsibility to follow their state's rules and regulations. An example of what preparations could be made in advance by State regulatory agencies are below.

1. Technical requirements and procedures for landfilling of HPAI waste is established by the State-level regulatory agency responsible for permitting of landfills (State environmental agency). These requirements are designed to be protective of human health and the environment, to not jeopardize the structural or operational integrity of the landfill, and to allow the facility to operate in compliance with their land disposal facility permit. Federal/State agencies charged with protecting animal health, biosecurity, and disease control are responsible for establishing any additional technical requirements and procedures pertaining to their authorities.
2. The State environmental agency may survey all potentially qualified land disposal facilities to determine their interest in accepting HPAI wastes. Information on the technical requirements and procedures for land disposal of HPAI wastes should be included in the communication so landfills can perform an initial evaluation of their facility's capability in regards acceptance of HPAI wastes.
3. The landfill notifies the State environmental agency of its willingness to accept HPAI wastes.
4. The State environmental agency meets with landfill representatives to evaluate the suitability of their facility to accept HPAI wastes. The evaluation includes the following topics:
  - a. Area within the landfill for disposal of HPAI wastes; verification that the area is underlain by a leachate collection system.



- b. Number of acres available for disposal of HPAI wastes.
- c. Thickness of already-disposed waste layer between surface of landfill and leachate collection system.
- d. Leachate management activities and method for disposal of excess leachate.
- e. Logistics of HPAI waste acceptance and coordination of HPAI waste acceptance with acceptance of routine waste streams.
- f. Gas collection system – location and any necessary operational changes during HPAI waste disposal activities to reduce the risk of fires.
- g. Public relations and community outreach – discuss how the public and local elected officials will be informed of and educated about potential HPAI waste landfilling activities at the facility.

## TYPICAL EMERGENCY LANDFILL PROCEDURES, ROLES, AND RESPONSIBILITIES

1. The landfill agrees to receive infected birds.
2. State provides permits and permit conditions to landfill.
3. Contracted service visits the landfill to evaluate access, and works with the landfill to:
  - a. plan traffic routing for trucks carrying HPAI waste,
  - b. select the location for vehicle C&D, and
  - c. select C&D wash water disposal option(s).
4. The landfill consults with the local Incident Command on costs.
5. A biosecurity station is set up for vehicle and personnel C&D.
6. The contractor provides, loads, and disinfects outbound trucks at origin (e.g., sealed roll-offs lined with plastic to allow bags to slip out; biocontainment bag placed in roll-off over liner; 1 foot wood chips placed in bottom of bag; birds loaded to within 1 foot of top of roll-off; biocontainment bag sealed; roll-off disinfected and tarped).
7. USDA provides a permit for the truck to leave the infected premises.
8. The contractor or subcontractor drives the truck to the landfill and prepares to dump where directed by landfill staff or designee.
9. The truck driver tips load where directed.
10. The contractor or landfill personnel covers the waste material.
11. The landfill manages leachate in accordance with permit conditions.
12. The contractor or subcontractor drives the truck to the C&D station for washing prior to leaving landfill.
13. The contractor or subcontractor disposes of C&D wash water in accordance with the landfill and State requirements (likely at the municipal wastewater treatment plant).

## FOR FURTHER INFORMATION

Please see the following websites for further information concerning HPAI:

- ◆ [FAD PReP Material and References](#)
- ◆ [USDA APHIS Avian Influenza 2016 Response](#)
- ◆ [Risk Assessment Study Leachate from Landfills](#)

## Aerial View of Landfill Staging

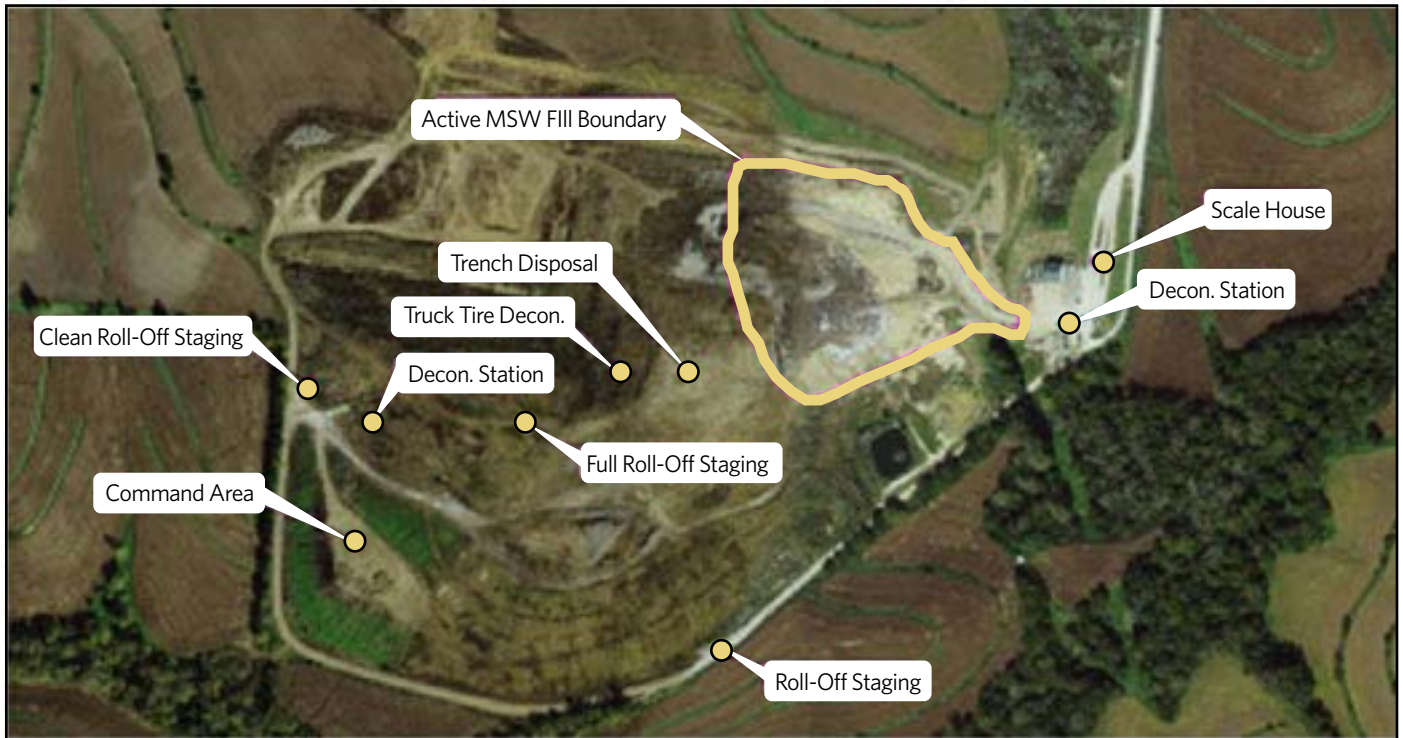

Please see the following websites for further information:

[www.aphis.usda.gov/fadprep](http://www.aphis.usda.gov/fadprep)

[go.usdatraining.com/HPAI](http://go.usdatraining.com/HPAI)

# CDC Interim Guidance for Landfill Workers in the United States Disposing of Poultry Carcasses During Outbreaks of Highly Pathogenic Avian Influenza

---

## A. PURPOSE AND BACKGROUND

The purpose of this document is to provide information and guidance for workers at landfill sites in the United States where poultry carcasses are disposed of during outbreaks of highly pathogenic avian influenza (HPAI) A(H5N2) virus. Landfill workers include mechanical equipment operators, individuals standing on the surface of the landfill when carcasses are deposited, and personnel having direct physical contact with AI virus-infected bird carcasses or potentially infected materials.

Avian Influenza (AI) Viruses:

- Avian influenza (AI) viruses circulate naturally among wild birds, particularly the waterfowl reservoir, and readily enter domestic bird/poultry populations.
- Most AI viruses are low pathogenic and do not cause serious illness among infected birds or people. Highly pathogenic AI viruses often cause severe illness and death in infected poultry.
- AI viruses can spread quickly among birds.
- AI virus infections of people are rare, but can occur.

The HPAI H5N2 virus that caused poultry outbreaks during 2014-2015 in North America is an emerging virus. Preliminary laboratory studies indicate that this HPAI H5N2 virus is not well-adapted to humans. However, sporadic severe and fatal human respiratory illness from infections with other closely related HPAI A(H5) viruses (e.g. H5N1, H5N6) have occurred in other countries. Most human infections with avian influenza A viruses have occurred in persons not using appropriate personal protective equipment (PPE) who had exposures consisting of either 1) direct physical contact with infected birds or surfaces contaminated by the viruses; 2) being in close proximity (e.g. within 2 meters) to infected birds; or 3) visiting a live poultry market. Although no human infections with HPAI H5N2 virus have been reported to date, direct or close (e.g. within 2 meters) contact without PPE to infected birds or virus-contaminated environments may increase the risk of human infection. To reduce their risk of HPAI H5N2 virus infection, landfill workers should use appropriate PPE when disposing of poultry carcasses during outbreaks of HPAI. The following guidance, although developed for an outbreak of HPAI A(H5N2) virus, also applies to disposal of poultry carcasses during outbreaks of HPAI H5N8 and HPAI H5N1 viruses. Consultation and close coordination with public health departments are recommended.

Key points: To reduce the risk of HPAI virus infection, landfill workers should do all of the following:

Wear recommended personal protective equipment (PPE): gloves, boots, protective coveralls, goggles and a respirator) when in direct contact with infected birds, poultry carcasses, and/or poultry feces or litter;

- Avoid unprotected direct physical contact with ill birds or poultry carcasses;
- Avoid unprotected direct physical contact with bird droppings/feces from HPAI virus-infected birds;
- Wash hands with soap and water after removing gloves and other PPE. If soap and water are not readily available, alcohol-based hand rubs may be used, but must be followed by washing with soap and water once it becomes available because hand sanitizers do not reduce organic load (e.g., dirt);
- Report any illness that occurs within 10 days of the past exposure to poultry carcasses or potentially infected materials (see section C. below for more details).

## B. GUIDANCE FOR LANDFILL WORKERS DISPOSING OF POULTRY CARCASSES

1. Bury the AI virus-infected bird carcasses and materials immediately (within 30 minutes) after unloading at the landfill.
2. Whenever possible, avoid physical handling of the carcasses by using mechanical equipment such as trucks and backhoes with enclosed cabs.
3. All landfill workers should:
  - a. Use PPE including: properly-fitted safety goggles, disposable gloves, boots, a NIOSH-certified respirator (e.g., N95), and disposable fluid-resistant<sup>1</sup> coveralls.
    1. NIOSH-certified N95 (or higher) respirators are recommended for landfill workers who have contact with AI virus-infected carcasses or potentially infected materials. Respirator use should be in the context of a complete respiratory protection program in accordance with the Occupational Safety and Health Administration (OSHA) Respiratory Protection standard (29 CFR 1910.134) and other requirements. Staff that will need to wear N95 (or higher) respirators should be medically-cleared, trained, and fit-tested for respirator use. Detailed information on respiratory protection programs, including fit testing procedures, can be accessed at OSHA's Respiratory Protection eTool: ([www.osha.gov/SLTC/etools/respiratory](http://www.osha.gov/SLTC/etools/respiratory)).

Training topics should include all of the following:

- a. Proper fit-testing, wearing and use of respirators;
  - b. Safe removal of respirators;
  - c. Safe disposal of disposable respirators or cleaning and disinfection of reusable respirators;
  - d. Medical contraindications to respirator use.
2. Reusable PPE should be:
    - a. Cleaned until visible dirt is removed, and then
    - b. Disinfected with an EPA approved disinfectant that has label claims against influenza A viruses according to the manufacturer's instructions.

<sup>1</sup> Fluid-resistant coveralls should be made of fabric that passes:  
 AATCC 42 M1 g and AATCC 127 U50 cmH<sub>2</sub>O or EN20811 U50 cmH<sub>2</sub>O; or  
 ASTM F1670 (13.8kPa); or  
 ISO 16603 U3.5 kPa

3. Respirator use is not necessary inside enclosed cabs when the cab's tra on system has been independently evaluated against the NIOSH leak test method for enclosed cab tra on systems and it can be demonstrated that the cab provides the same, or higher level, of protection as an N95 respirator. The NIOSH leak test method for enclosed cab tra on systems are available on the web at <https://www.cdc.gov/niosh/mining/userfiles/works/pdfs/2019-124.pdf>.
  4. All PPE should be used in accordance with OSHA regulations found at 29 CFR 1910 Subpart I (Personal Protective Equipment). Workers should receive training on and demonstrate an understanding of when to use PPE; what PPE is necessary; how to properly put on, use, take off, properly dispose of, and maintain PPE; and the limitations of PPE.
  5. Land workers who may have direct contact with carcasses or potentially infectious materials (e.g. individuals responsible for opening the roll of container for unloading) should wear a disposable impermeable<sup>2</sup> coverall in place of the uid resistant coverall referenced above or an apron over the uid resistant coverall to protect against exposure to liquids.
- b. Safely remove PPE after burial in sequence:
    1. Remove and dispose of the apron, if worn;
    2. Clean and disinfect boots;
    3. Remove boots;
    4. Remove and dispose of the coverall;
    5. Remove and dispose of gloves;
    6. Wash hands with soap and water;
    7. Remove goggles and respirator;
    8. Clean and disinfect reusable goggles and respirator;
    9. Wash hands with soap and water again.
  - c. Put on and take o PPE in separate clean areas;
  - d. Perform good hand hygiene such as hand washing with soap and water or using an alcohol based hand rub a removing PPE;
  - e. Avoid touching eyes, mouth, nose after touching any contaminated material while wearing PPE;
  - f. Do not eat, drink, smoke, or use the bathroom while wearing PPE.

<sup>2</sup> Impermeable Coveralls Shouldve Made Of fabric and seams closures that pass ASTM F1671 (13.8kPa);or ISO 16604 14 kPa

### C. REPORTING OF ILLNESS

1. Workers at the landfill should monitor their health starting on the first day of exposure and for ten days after the last exposure to material and poultry carcasses from affected farms, and report any illness signs or symptoms (e.g. fever or feeling feverish, cough, runny nose, sore throat, headache, muscle aches, eye redness, difficulty breathing, shortness of breath, diarrhea, etc.) to the local and state public health department as soon as possible.
2. Additional information about avian influenza and worker protection can be found at:
  - a. NIOSH Avian Influenza: <https://www.cdc.gov/niosh/topics/avianflu/>
  - b. OSHA Guidance for Protecting Employees Against Avian Flu: [https://www.osha.gov/sites/default/files/publications/avian\\_flu\\_guidance\\_english.pdf](https://www.osha.gov/sites/default/files/publications/avian_flu_guidance_english.pdf)
  - c. CDC Information on Avian Influenza: <http://www.cdc.gov/flu/avianflu/>
  - d. CDC H5 Viruses in the United States: <https://archive.cdc.gov/#/details?url=https://www.cdc.gov/flu/avianflu/h5/index.htm>
  - e. CDC Prevention and Treatment of Avian Influenza A Viruses in People: <http://www.cdc.gov/flu/avianflu/prevention.htm>
  - f. CDC Interim Guidance on Influenza Antiviral Chemoprophylaxis of Persons Exposed to Birds with Avian Influenza A Viruses Associated with Severe Human Disease or with the Potential to Cause Severe Human Disease: <http://www.cdc.gov/flu/avianflu/guidance-exposed-persons.htm>
  - g. OSHA Guidance Update on Protecting Employees from Avian Flu (Avian Influenza) Viruses: <https://www.osha.gov/avian-flu/control-prevention#:~:text=General%20Precautions%20for%20Workers,with>
  - h. OSHA Safety and Health Topics Page for Avian Flu: <https://www.osha.gov/avian-flu/>
  - i. OSHA Avian Flu Fact Sheet: [https://www.osha.gov/sites/default/files/publications/OSHA\\_FS-4189.pdf](https://www.osha.gov/sites/default/files/publications/OSHA_FS-4189.pdf)
  - j. OSHA Avian Flu Quick Card: [https://www.osha.gov/sites/default/files/publications/avian\\_flu\\_food\\_handlers.pdf](https://www.osha.gov/sites/default/files/publications/avian_flu_food_handlers.pdf)
  - k. OSHA Safety and Health Information Bulletin (SHIB) on Avian Flu: <https://www.osha.gov/shib>

### D. REFERENCES

1. Senne DA, Panigrahy B, Morgan RL. Effect of composting poultry carcasses on survival of exotic avian viruses: highly pathogenic avian influenza (HPAI) virus and adenovirus of egg drop syndrome-76. Avian Dis. 1994 Oct-Dec;38(4):733-7.
2. Guan J, Chan M, Grenier C, Wilkie DC, Brooks BW, Spencer JL. Survival of avian influenza and Newcastle disease viruses in compost and at ambient temperatures based on virus isolation and real-time reverse transcriptase PCR. Avian Dis. 2009 Mar;53(1):26-33.

## STANDARD OPERATING PROCEDURES: 14. DISPOSAL

## Attachment 14.C Landfilling

---

### Planning

1. Contact state environmental agency for approval to landfill waste.
2. Identify permitted Subtitle D landfills in the vicinity of the affected premises (see EPA's I-WASTE Tool at <http://www2.ergweb.com/bdrtool/login.asp> for a database of disposal facilities).
3. Contact identified landfills and ensure operator will accept catastrophic FAD mortalities, and the conditions of acceptance.
4. Verify the availability of adequate carcass storage facilities such as refrigerated rooms, transport vehicles, freezers or other means of carcass preservation.
5. Identify haulers who:
  - a. Are equipped to haul carcasses in accordance with State and Federal laws.
  - b. Can provide secure, leak-resistant, covered, transport for the infected carcasses and contaminated materials.
  - c. Employ appropriately licensed drivers.
  - d. Possess vehicles in good mechanical condition and capable of carrying the load without difficulty.
  - e. Have vehicles which can be covered with a tarpaulin if they do not have closed tops.
  - f. Employ drivers adequately trained in biosecurity (see 49 CFR 172 and 173 DOT regulations for further guidance).
  - g. Have an emergency plan and associated supplies which address spills/excess leakage; vehicle break-downs; traffic accidents; adverse weather conditions; and terrorist attacks.

### Operations

1. Don all required PPE as detailed in the Site-Specific Health and Safety/PPE Plan.
2. Prior to loading each vehicle, confirm with landfill operator(s) that they will accept the load of disease-infected carcasses. Inform landfill contact person about space, personnel, safety, and biosecurity requirements.
3. If the vehicle is not leak-resistant with a sealed cover, line the vehicle with plastic sheeting or bags and place one foot of absorbent bedding material over the liner to cushion the load and minimize the risk of puncturing the liner.
4. Puncture/vent the carcass by stabbing the area posterior to the ribs and the thoracic and abdominal cavities.
5. Load punctured carcasses into lined/leak-resistant vehicle leaving at least one foot of space at the top.
6. Seal full load.
7. Disinfect exterior of vehicle.

8. Prepare all placards and manifests in accordance with applicable regulations.
9. Obtain controlled movement permit from state.
10. Maintain a log of all shipments including
  - a. the amount and type of material hauled;
  - b. address of originating premises;
  - c. location of landfill, contact name and contact phone number;
  - d. transport vehicle license and registration numbers;
  - e. driver name and contact information;
  - f. supervisor's name and signature;
  - g. C&D checklist;
  - h. time/date of departure from premises and arrival at disposal site;
  - i. unique reference number for each load; and
  - j. any unusual circumstances.
11. Transport load to the landfill. using transport routes that minimize exposure to susceptible premises.
12. Check in at weigh station.
13. Obtain receipt for weight of load and any tipping fees.
14. Proceed to working face of landfill as directed by landfill staff.
15. Have site operators open the tailgate; not the driver.
16. Tip the vehicle into the hollow under the working face or as directed by the landfill operator.
17. Landfill operators should cover carcasses immediately.
18. Proceed to designated biosecurity station to disinfect vehicle before leaving the landfill. See the Biosecurity and Health and Safety/PPE SOPs.
19. Properly clean and disinfect all site machinery used in the operation. See the NAHEMS Guidelines: C&D and the C&D SOP.
20. All individuals involved in the disposal process must wear appropriate PPE. See the NAHEMS Guidelines: Health and Safety, NAHEMS Guidelines: PPE, and the Health and Safety/PPE SOP.

Table 14.C-1 compares recommended actions for handling and disposing of carcasses for routine, noninfectious material and potentially infectious material.



Figure 14.C-1. Recommended Actions for Handling and Disposal of Carcasses During Burial and Landfill<sup>15</sup>

Prepare waste profile paperwork	Excavate site before carcass arrival and cover with soil immediately after burial
Cover transportation vehicles (with tarp or similar covering)	Avoid transportation of carcasses through neighborhoods
Avoid free liquids by using adsorbent materials	Dispose of infectious material in a separate area of the landfill
Minimize odors with quick, efficient handling	Monitor air for presence of bacteria
Avoid personnel coming into direct contact with materials	Use proper personal protection equipment for workers unloading infectious material
Bury as soon as possible	Dispose of material 40 feet above leachate collection system
Keep birds and vermin away from working landfill surface as much as possible	Implement formal bird-control program on landfill surface
Account for stability considerations if volume is large, because subsidence may be significant and the decaying carcasses may be slimy and have little geotechnical strength	Map and record vault disposal area and store information with asbestos data
	Decontaminate transportation vehicles
	Protect heavy-equipment operators by using pressurized cabs
	Hire specialized contractors to handle infectious material (biosecurity)

<sup>15</sup> CAST [Council for Agricultural Science and Technology]. “Ruminant Carcass Disposal Options for Routine and Catastrophic Mortality.” Issue Paper, No. 41: January 2009. <http://www.cast-science.org/>

## Standard Operating Procedures: Rendering

---

In carcass rendering, whole carcasses are mechanically crushed into 2 inch<sup>1</sup> cubes of tissues, broken down thermally, and sterilized in a sealed and controllable container using pressurized steam.<sup>2</sup> The process converts the carcasses into 60% water, 20% fat/tallow, and 20% meat/bone meal, which is often used as animal feed. Because the rendering plant will likely be located off the affected premises, the carcasses will have to be securely transported to the rendering plant.

### PLANNING

1. Identify carcass rendering plant(s) in the region of the affected premises– ideally one that participates in the Animal Protein Producers Industry (APPI) program to test for Salmonella in the meat and bone meal and has at least one person on-site who has received training by the APPI or a certified trainer from an equivalent program. Ensure that the rendering plant has a deodorizing system. See [National Renderers Association Directory](#).
2. Develop a memorandum of understanding (MOU) with nearby counties if county lines must be crossed to reach the identified rendering plant.
3. Coordinate with the managers of the rendering plants about rendering infected carcasses. Discuss with the managers at the rendering plant:
  - a. The responsible party for cleaning and disinfection (C&D) after rendering is complete.
  - b. Potential compensation for use of the facility.
  - c. The volume of carcasses accepted per day.
4. Make all necessary arrangements for the transportation and delivery of carcasses to the plant, making use of the renderer’s hauling service if appropriate.
5. Ensure that all rendering plant personnel are trained on proper procedures for rendering infected carcasses, biosecurity procedures, work safety issues, and the use of personal protective equipment (PPE). If not,
6. Train the rendering plant personnel on biosecurity, work safety issues, and the use of PPE based on the Code of Practice approved October 18, 2004, by the North American Rendering Industry, as well as the Site Specific Disposal Plan, the NAHEMS Guidelines: Biosecurity, Biosecurity SOP, NAHEMS Guidelines: Health and Safety, NAHEMS Guidelines: PPE, and the Health and Safety/PPE SOP or use engineering controls to contain the system so exposures are minimized.
7. Have a Disposal Team Member available to facilitate the rendering process of disease- infected carcasses.
8. Employ biosecurity zones in the plant to minimize the risk of contamination from carcass materials entering, and of finished products exiting, the processing plant.
9. Ensure all rendering permit conditions are met and ensure pathogens that may be emitted as aerosols from the process, particularly near the grinders are contained.

<sup>1</sup> <https://www.fda.gov/animal-veterinary/guidance-industry/bovine-spongiform-encephalopathy-bse-guidances>

<sup>2</sup> <https://nara.org/appi-code-of-practice>

**OPERATIONS**

1. Don all required PPE as detailed in the Site-Specific Health and Safety/PPE Plan.
2. If possible, use the rendering company's carcass pickup service. Regardless of the transportation provider, the transport of infected carcasses off premises must follow the transportation procedures outlined in *Standard Operating Procedures: Transport*, on the following pages.
3. Perform the rendering process within 24 to 48 hours of an animal's death or as advised by rendering company.
4. Control and record the input rate relative to the size of the rendering vessel and verify that all locations in the vessel reach the minimum temperature and cooking time to inactivate the virus.
5. Properly maintain the carcass-receiving and finished-product sections as "dirty" and "clean" areas of the rendering plant and keep them separated.
6. Workers cannot move between the "dirty" and "clean" areas without personnel decontamination. See [go.usdatraining.com/NAHEMS\\_Biosecurity](https://go.usdatraining.com/NAHEMS_Biosecurity) and [go.usdatraining.com/SOP\\_Biosecurity](https://go.usdatraining.com/SOP_Biosecurity)
7. Routinely sanitize the equipment and maintain the tools used on the processing lines and in the facilities.
8. Prevent the drainage of liquids from dirty to clean areas to avoid contaminating the finished products and their transportation system.
9. Implement procedures to monitor odors and investigate and resolve odor-related complaints.
10. Monitor the cooking process.
11. Plan to dispose of the rendered products unless specifically authorized to use for pet feed. Disposal options for rendered product include composting, landfilling, or recycling at a cement kiln.
12. Thoroughly clean and disinfect all of the rendering plant equipment. See the NAHEMS Guidelines: C&D and the C&D SOP and any additional standards for returning the plant to normal production. Heating the plant to 12° F for 7 days may also be acceptable.

## Standard Operating Procedures: Transport

---

Transport vehicles will be needed to transport items (carcasses, other materials) to the disposal site whether it is on or off the premises. If the waste must be transported on public roads, it should be transported in closed, leak-resistant trucks or dumpsters. Secondary containment may be needed, depending on the type of waste being transported. Consult a qualified waste management professional when developing this section of the plan. Some other transport planning considerations are listed below.

- Do disposal facilities selected for this premises have any special requirements for incoming waste shipments?  
\_\_\_\_\_  
\_\_\_\_\_
- Have the disposal facilities agreed to accept the type and amount of waste you plan to send them and are they permitted appropriately?  
\_\_\_\_\_
- Have members of the disposal team visited the facility to ensure it is operated in accordance with all applicable laws and regulations?  
\_\_\_\_\_
- Is there an existing contract or agreement in place with the disposal facility to receive the material?  
\_\_\_\_\_
- Are all permit, agreement, and/or contract conditions delineated and will the shipments meet the conditions? If not, what corrective actions would be needed?  
\_\_\_\_\_  
\_\_\_\_\_
- Are haulers to be used for the response properly equipped to haul carcasses in accordance with all applicable laws?  
\_\_\_\_\_
- Are transport vehicles designed to handle the materials to be transported?  
\_\_\_\_\_
- Are the drivers adequately trained in biosecurity? (See 49 Code of Federal Regulations [CFR] 172 and 173 Department of Transportation [DOT] regulations for further guidance).  
\_\_\_\_\_
- Can two-way communications be maintained with the hauler during transport?  
\_\_\_\_\_
- Do shipments require law enforcement escorts?  
\_\_\_\_\_
- What travel routes will be used from the premises to the disposal site? (Consider road construction, neighborhoods, and densely populated areas, as well as susceptible farms).  
\_\_\_\_\_  
\_\_\_\_\_

- Has an alternate travel route been identified?

---

---

---

---

- What procedures will be followed if the vehicle is damaged during transit?

---

---

---

---

- Does the receiving facility have sufficient space for incoming vehicles to avoid causing traffic disruptions on access roads? Does it have a secure location for transport vehicles, freezers, or other means of storage if there is a delay of more than 1 day?

---

---

---

---

- Coordinate with State and local transportation authorities to verify any transport restrictions and obtain any necessary permit requirements and document these conditions in the site-specific plan.

---

---

---

---

- How will vehicles be cleaned and disinfected before leaving the affected premises and after materials have been offloaded at the disposal site? See [go.usdatraining.com/NAHEMS\\_Biosecurity](http://go.usdatraining.com/NAHEMS_Biosecurity) and [go.usdatraining.com/SOP\\_Biosecurity](http://go.usdatraining.com/SOP_Biosecurity) for more details.

---

---

---

---

- How is the waste classified for transport? What DOT packaging standards apply? Are all standards consistently met, including labeling, placarding, and manifesting?

---

---

---

---

- How will vehicle loading be performed in order to avoid releasing biological agent(s) into the environment?

---

---

---

---

- How will transport vehicle traffic be minimized into the Control Area?

---

---

---

---

# Example Rendering Plant Biosecurity Protocol



Infected materials will have temporal separation from the general rendering materials. They will be the last materials run in the plant at the end of a week. This will minimize cross contamination.



Infected material trailers will be sealed, tarped, and loaded per rendering norms or [University of Minnesota Risk Assessment](#).



Following offloading, the trailers will be washed per incident-specific protocols and will be cleaned at a commercial truck wash prior to returning to service.



Access points between raw material processing and finished product reduction and load out will be limited to one or two hand wash/boot wash station(s). All other access points will be sealed and no longer used. Workers will be required to clean and sanitize their hands and boots prior to entering the finished product handling area.

## Carcass Management: Rendering Checklist

---

- See a complete list of renderers at [go.usdatraining.com/NARA](https://go.usdatraining.com/NARA).
- Contact facilities and determine if they will accept your livestock or poultry and meet some or all of your capacity needs.
  - If the capacity is less than needed, can the carcasses be stored/refrigerated while awaiting disposal?
- If so, arrange for biosecure storage and transport to rendering facility for disposal.
  - Determine if any permits are required for transport of infected carcasses.
  - Determine type of transport vehicles required. If the waste must be transported on public roads, it should be transported in closed, leak resistant trucks or dumpsters. Secondary containment may be needed, depending on the type of waste being transported. Request assistance from the National Veterinary Stockpile through the Incident Management Command Team Logistics Branch.
  - Work with Depopulation Group Supervisor within the Incident Command System to determine how many animals can be depopulated per day and how many trucks will be needed for transport per day, ensuring the rates are about equal. If not, arrange for leak-resistant, covered storage.
  - Pre-identify transport routes to minimize exposure of susceptible premises.
- If rendering is an option, see the Secure Transport and Off-Site Treatment/Burial training modules at [go.usdatraining.com/Disposal\\_training](https://go.usdatraining.com/Disposal_training) and implement rendering. If not, continue to the next option.

## Carcass Management: Off-Site Incineration Checklist

---

- Contact environmental regulatory authorities to verify operations are not in violation of their air permits.
- Will State environmental agency approve incineration?
- If so, see a complete list of incinerators at the EPA database at [go.usdatraining.com/I-WASTE](https://go.usdatraining.com/I-WASTE).
  - Access the [I-WASTE tool website](#).
  - Choose treatment and disposal facilities button.
  - Enter filter criteria such as “facility type” (e.g. rendering, incinerators, or landfill).
  - Enter State or EPA region, and click “View List of Facilities” button or map facilities.
  - If the facilities are compliant, contact them and determine if they will accept your livestock or poultry and meet some or all of your capacity needs.
- If so, arrange for transport to off-site incineration facility for disposal.
  - Determine if any permits are required for transport of infected carcasses.
  - Determine type of transport vehicles required. If the waste must be transported on public roads, it should be transported in closed, leak-proof trucks or dumpsters. Secondary containment may be needed, depending on the type of waste being transported. For reference, see the [University of Minnesota Risk Assessment](#) which further details the transport process dependent on waste types.
  - Work with Depopulation Group Supervisor within the Incident Command System to determine how many animals can be depopulated per day and how many trucks will be needed for transport per day, ensuring the rates are about equal. If not, arrange for leak-resistant, covered storage.
  - Pre-identify transport routes to minimize exposure of susceptible premises.
- If off-site incineration is an option see the *Secure Transport* and *Off-Site Treatment/Burial* training modules at [go.usdatraining.com/Disposal\\_training](https://go.usdatraining.com/Disposal_training) or see [fixed incinerator instructions](#) and implement off-site incineration. If not, and you still need to dispose of animals, inform Operations Chief and discuss alternate strategies such as centralized carcass management or vaccination. Return to First Option and repeat cycle until all carcasses can be managed.



## STANDARD OPERATING PROCEDURES: 14. DISPOSAL

## Attachment 14.D Fixed Incineration

---

### Planning

1. Identify permitted pathological waste incinerators in the vicinity of the affected premises (see EPA's I-WASTE Tool at <http://www2.ergweb.com/bdrtool/login.asp> for a database of disposal facilities).
2. Contact identified facilities and ensure operator will accept catastrophic FAD mortalities, and the conditions of acceptance.
2. Contact state environmental agency for approval.
3. Verify the availability of adequate carcass storage facilities such as refrigerated rooms, transport vehicles, freezers or other means of carcass preservation if storage will be needed.
4. Identify haulers who:
  - a. Are equipped to haul carcasses in accordance with State and Federal laws.
  - b. Can provide secure, leak resistant transport for the infected carcasses and contaminated materials.
  - c. Employ appropriately licensed drivers.
  - d. Possess vehicles in good mechanical condition and capable of carrying the load without difficulty.
  - e. Have vehicles which can be covered with a tarpaulin if they do not have closed tops.
  - f. Employ drivers adequately trained in biosecurity (see 49 CFR 172 and 173 DOT regulations for further guidance).
  - g. Have an emergency plan and associated supplies which address spills/excess leakage; vehicle break-downs; traffic accidents; adverse weather conditions; terrorist attacks.

### Operations

1. Don all required PPE as detailed in the Site-Specific Health and Safety/PPE Plan.
2. Prior to loading each vehicle, confirm with incinerator operator(s) that they will accept the load of infected carcasses.
3. Inform contact person about space, personnel, safety, and biosecurity requirements.
4. If the vehicle is not leak-resistant with a secure cover, line the vehicle with plastic sheeting or bags and place one foot of absorbent bedding material over the liner to cushion the load and minimize the risk of puncturing the liner.
5. Puncture/vent the carcass by stabbing the area posterior to the ribs and the thoracic and abdominal cavities.
6. Load punctured carcasses into leak-resistant or lined vehicle, leaving one foot free space at the top.
7. Securely cover load.
8. Disinfect exterior of vehicle.

9. Prepare all placards and manifests in accordance with applicable regulations.
10. Obtain permit for controlled movement from state.
11. Maintain a log of all shipments including
  - a. the amount and type of material hauled;
  - b. address of originating premises;
  - c. location of incinerator, contact name, and contact phone number;
  - d. transport vehicle license and registration numbers;
  - e. driver name and contact information;
  - f. supervisor's name and signature;
  - g. C&D checklist;
  - h. time/date of departure from premises and arrival at disposal site;
  - i. unique reference number for each load; and
  - j. any unusual circumstances.
12. Transport load to the incinerator
13. Check in at weigh station if applicable.
14. Obtain receipt for weight of load and any disposal fees.
15. Proceed to unloading area as directed by facility staff.
16. Have site operators open the tailgate; not the driver.
17. The carcasses should be covered immediately and kept covered until they are moved to temporary storage or to processing.
18. Incinerate the carcasses in accordance with facility protocols.
19. Ensure the facility follows all biosecurity requirements.
20. Proceed to designated biosecurity station to disinfect vehicle before leaving the facility. See the Biosecurity and Health and Safety/PPE SOPs.
21. Properly clean and disinfect all site machinery used in the operation. See the NAHEMS Guidelines: C&D and the C&D SOP.
22. All individuals involved in the disposal process must wear appropriate PPE. See the NAHEMS Guidelines: Health and Safety, NAHEMS Guidelines: PPE, and the Health and Safety/PPE SOP.

## STANDARD OPERATING PROCEDURES: 14. DISPOSAL

## Attachment 14.E Air-Curtain Incineration

---

### Planning

1. Consult with appropriate State regulatory agencies for air quality and solid-waste permits before initiating operations.
2. Inform any other local authorities about the planned thermal destruction as required.
3. Ensure that equipment, and spare parts, are available for the chosen thermal method.
4. Ensure enough trained personnel are available to maintain continuous operations.
5. Provide appropriate sustenance and housing needs for disposal personnel if necessary.
6. Assuming a mobile air-curtain incinerator will be brought to the affected premises, verify the availability of air curtain incineration units and carcass storage facilities such as refrigerated rooms, transport vehicles, freezers or other means of carcass preservation.
7. Consult with USDA NRCS and evaluate the affected premises for the depth to the water table and proper soil conditions if trench burners will be used.
8. Use refractory boxes on sites with a high water table or on rocky soil and where trenches would be difficult or costly to build.
9. Locate the mobile air-curtain unit in an area that is easily accessible to heavy vehicles hauling carcasses and equipment.
10. Gather the appropriate materials such as solid fuels (straw, hay, coal, kindling wood, untreated lumber). Base the amount of solid fuels to use on the amount of moisture in the wood or other organic sources (hay, grain, stalks, and straw) and the fat and moisture content of the carcasses. Use a fuel-to-carcass weight ratio ranging from 1:1 to 2:1. Ensure availability of enough fuel to last 2-3 days or the length of time needed to maintain uninterrupted supply.

### Operations

1. Don all required PPE as detailed in the Site-Specific Health and Safety/PPE Plan.
2. Build the appropriate sized trench based on equipment vendor recommendations, or use refractory boxes. See NAHEMS Guidelines: Disposal.
3. Monitor the wind direction before and during the burning operations.
4. Keep workers out of the path of the flame.
5. Handle the ash in the refractory boxes carefully and dispose of it at a burial or land application site that has been approved by the appropriate regulatory agency.
6. If a large number of animal carcasses (exceeding a cumulative weight of 1 million pounds) require destruction, conduct the thermal destruction at a distance of 2 miles from residential buildings, roads, and utilities.
7. Use proper precautions when dealing with certain FADs such as HPAI to prevent personnel inhalation of airborne pathogens. Personnel must use proper PPE. See the NAHEMS Guidelines: Health and Safety, NAHEMS Guidelines: PPE, and disease specific Health and Safety/PPE SOPs for more information.
8. Thoroughly clean and disinfect all of the disposal equipment. See the C&D and Biosecurity SOPs.

## Loading Procedures

See Secure Transport training module at [go.usdatraining.com/Disposal](http://go.usdatraining.com/Disposal) and implement transport phase.

### PRE-LOADING

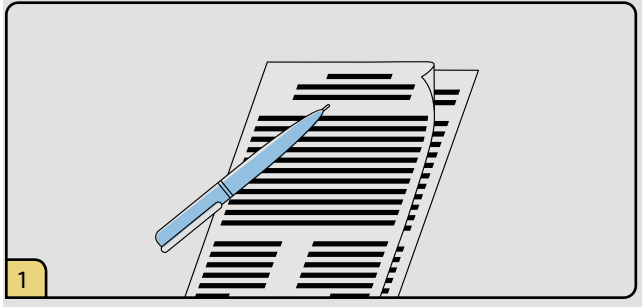

1 Complete all paperwork including manifests and/or controlled movement permits.

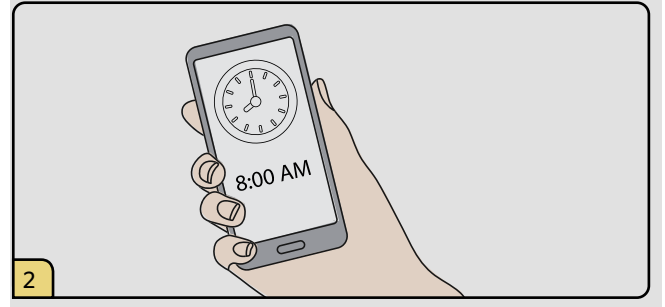

2 Order through ICS Logistics by 10:00 a.m. of the day prior to transporting. Specify type of delivery, type of container, size of waste, delivery time window, bin identification number, and contact name and phone number for job site.

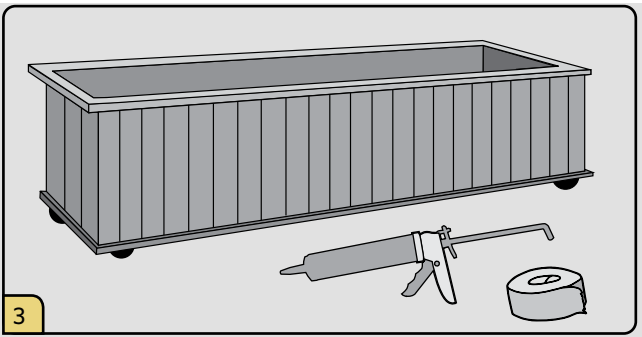

3 Inspect and line the containers. Seal any holes or spaces with duct tape, plastic liner, caulk, or silicone. Return containers that you cannot seal.

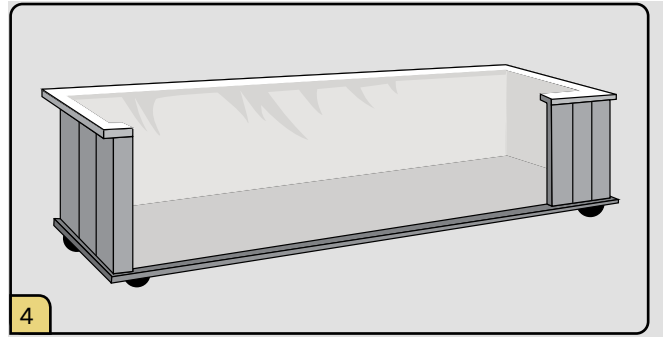

4 Insert BIO-ZIP or similar bag.



5 Rake one foot of absorbent material on the container floor with a heavier concentration near the rear door. Close container and adjust plastic and absorbent material as needed.

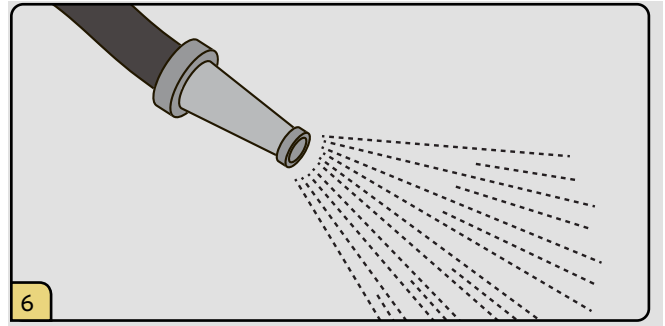

6 Disinfect carcasses and/or byproducts to minimize virus spread.

#### PRECAUTIONS



- Clean and degrease work area and equipment.
- Inform driver of all activities.
- Drivers should wear PPE at all times.
- Drivers should remain seated in vehicle with windows and doors closed while truck is loaded.

Source: USDA-APHIS Secure Transport Training Module ([go.usdatraining.com/transport](http://go.usdatraining.com/transport)).

LOADING

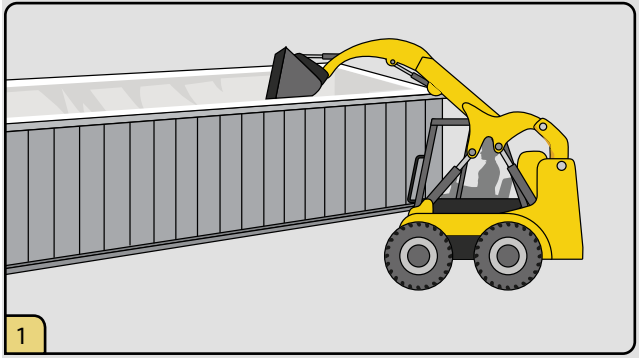

1 Load container with carcasses using a skid steer loader and/or front-end loader. Ensure carcasses are not placed on the ground while moving from the staging area to the container.

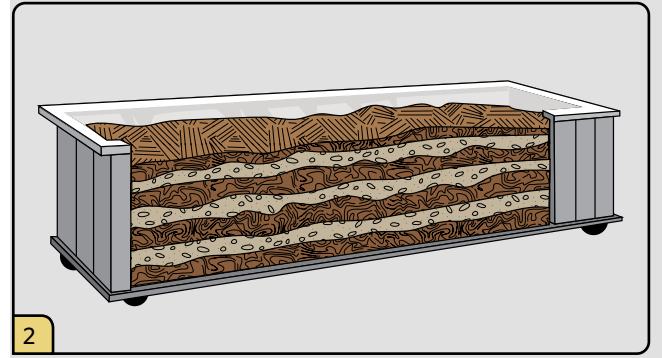

2 Load carcasses evenly. Alternate one foot of absorbent material with each layer ending with absorbent material.

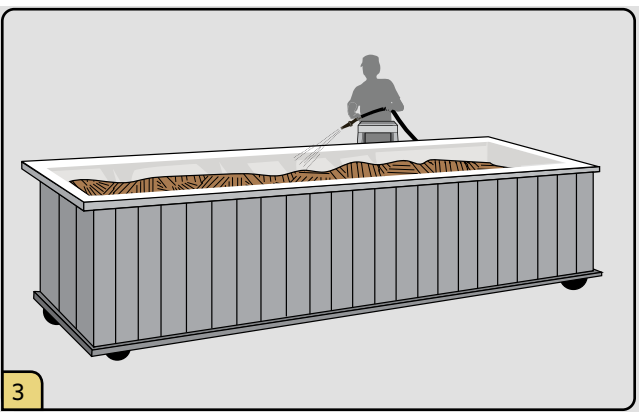

3 Load is full when contents reach maximum weight limit or fill container is one foot from the top of the container.

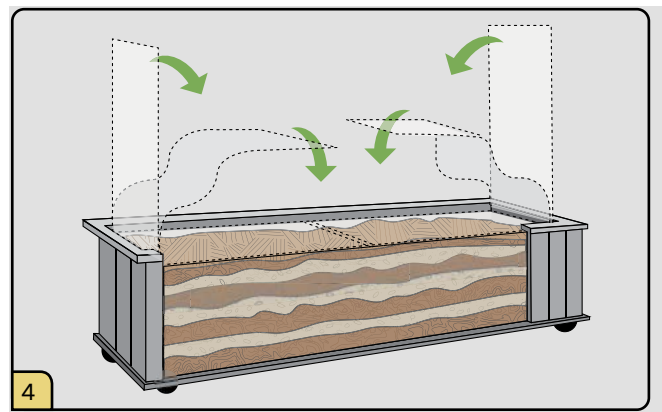

4 Seal BIO-ZIP bag or similar.

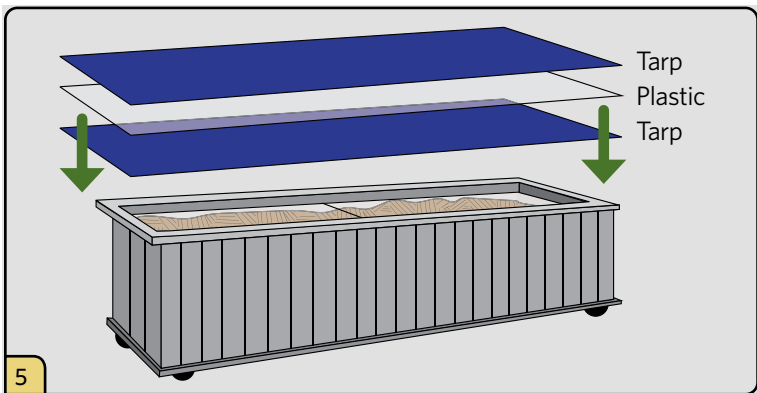

5 If container does not have a lid, securely fasten a tarp to the top.

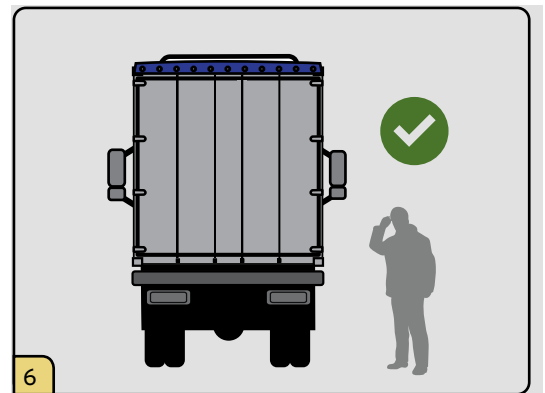

6 Disinfect and inspect vehicle before departure. Verify the load is not too large, and there are no leaks, cuts, or holes. If the load is dripping, the contents must be transferred to a correctly lined container.

PRECAUTIONS



- Sheet roll-off bins on the ground.
- Use fixed ladders to enter bins.
- Use at least two people to line bins.
- Conduct heavy lifting mechanically.
- Avoid climbing the sides, backs, or onto roll-offs during inspection.
- Avoid standing or walking on top of carcasses.

POST-LOADING

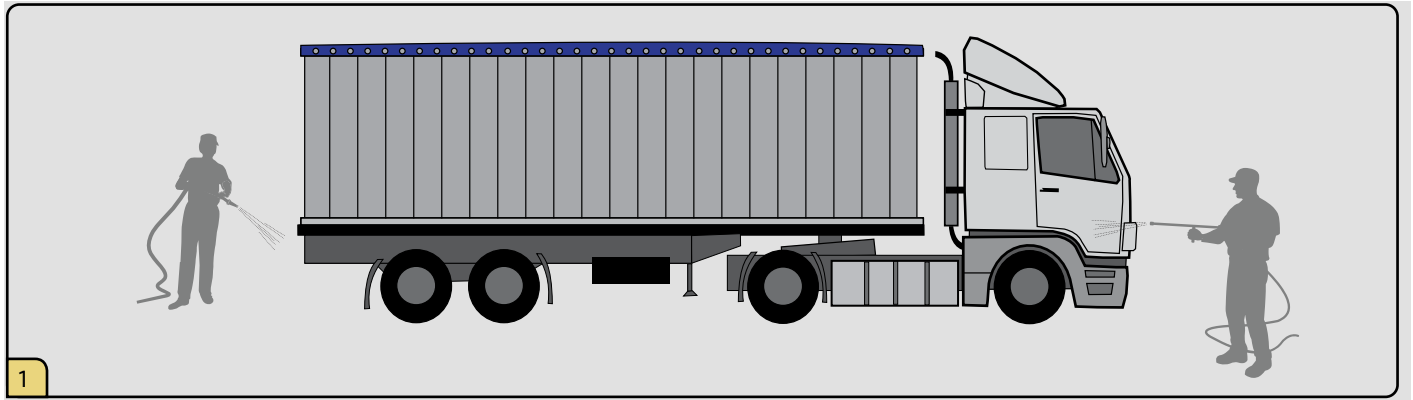

Clean and disinfect the outside of the truck and the container. Decontamination area must be a one-way system. Animal health technicians, site managers, or case managers will supervise process and issue a permit documenting proper disinfection.

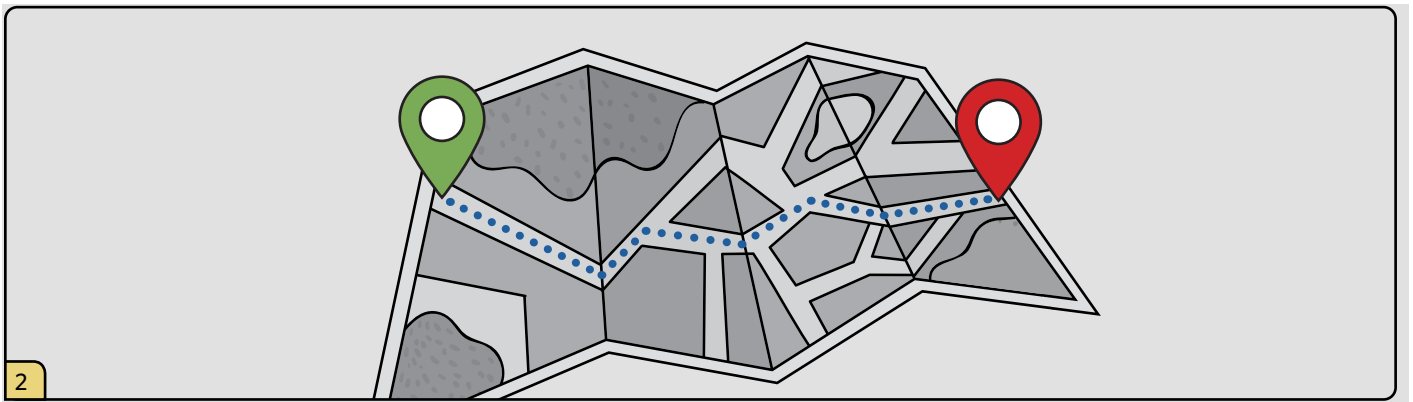

Use pre-arranged route. No unplanned stops are permitted.

PRECAUTIONS



- Wear PPE at all times.
- Ensure drivers turn off engines prior to decontamination.
- Create a one-way system for decontamination area.
- Disinfect undercarriage, wheels, and wheel wells.
- Beware of vehicle movements, disinfectants, and spread of disease.

# Permit Requirements

---

## Information Required for a Permit

- ✓ **Permit Class** — location, e.g., into CA, out of CA, or within CA.
- ✓ **Permit Reason** — reason for permit, e.g., direct to farm, direct to landfill, or into commerce.
- ✓ **Origin Premises** — Must be in EMRS2.
- ✓ **Destination Premises** — Must be in EMRS2.
- ✓ **Items** — What is allowed to move, e.g., manure/litter, feed, eggs, groups of animals.
- ✓ **Item Class** — Further description of item, e.g., if the item permitted was “groups of animals,” the item class offers further information.
- ✓ **Duration/Span of Permit** — First movement date, as well as how long the permit is valid for.

## Additional Requirements Prior to Movement

- ✓ Permits and their associated permitted movement may have additional requirements that must be met before the movement is made.
- ✓ These records and documentation can be uploaded in EMRS2 for review by relevant parties.
- ✓ For example, diagnostic testing or mortality reports from the premises may be required.
- ✓ Diagnostic testing results can be entered into EMRS2 or automatically messaged, if the testing laboratory can message results (strongly preferred), and attached to the origin premises in EMRS2.

# Overview of the Eight Steps in Interstate Permitted Movement

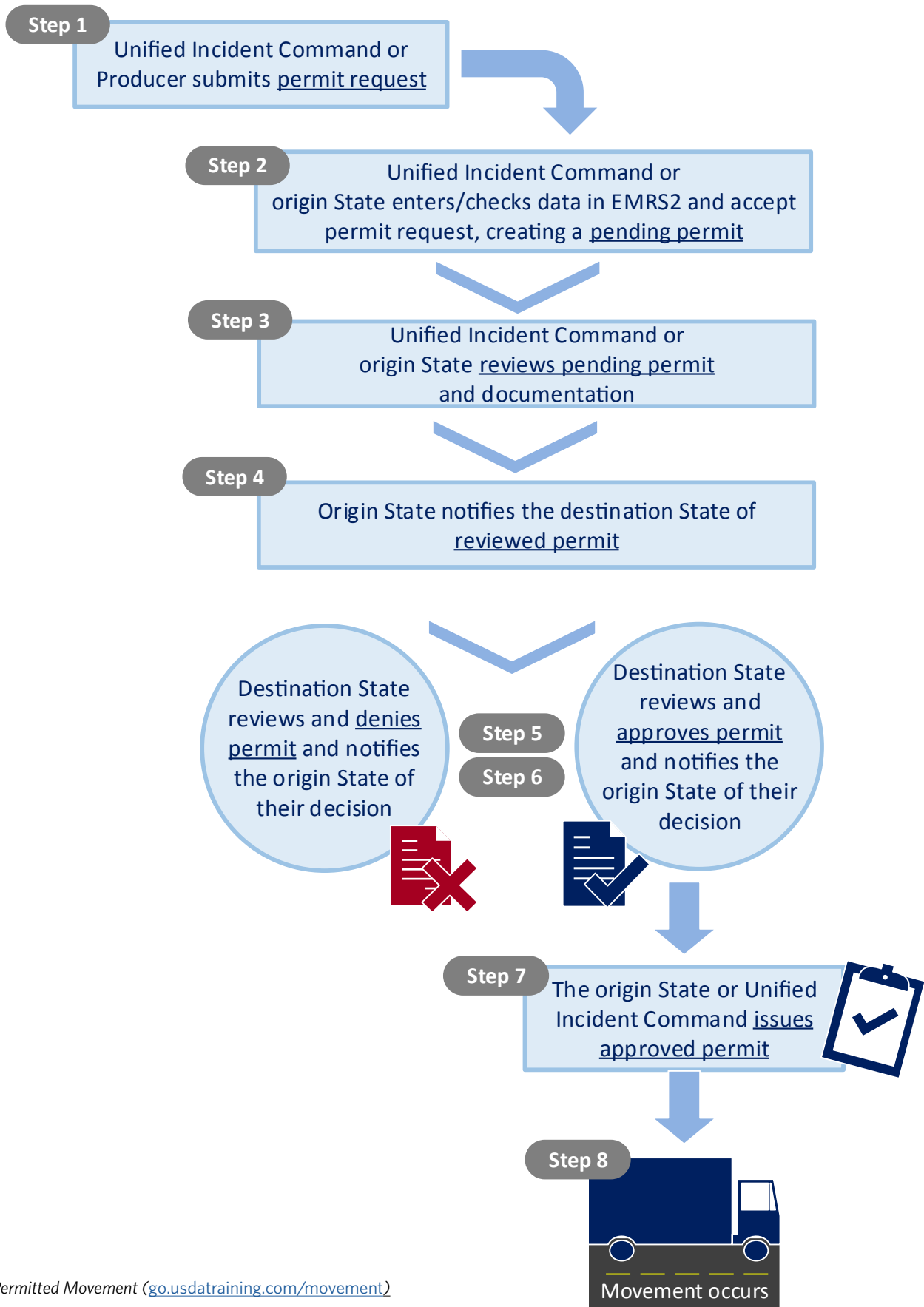

Source: Permitted Movement ([go.usdatraining.com/movement](http://go.usdatraining.com/movement))



## Transport Methods in Order of Risk

DESCRIPTION	RISK	AVAILABILITY	PRICE	NOTES
Rendering Truck + BIO-ZIP Bag	Negligible	Low	Medium	Limited supply of rendering trucks - BioZip bags can run out if not ordered in advance.
Liquifaction + Vac Truck	Negligible	Low - Medium	High	Systems in limited supply, trucks more common; INACTIVATES VIRUS .
Roll-Off with BIO-ZIP Bag	Negligible - Low	Medium	Low - Medium	Roll-offs widely available, BIO-ZIP bags can run out if not ordered in advance.
Rendering Truck (tailgate sealed and tarp cover)	Negligible - Low	Low - Medium	Low - Medium	Limited supply of rendering trucks.
Roll-Off with Liner and Cover	Moderate	Medium - High	Low - Medium	Roll-offs and plastic sheeting widely available.

Adapted by LPMiller from University of Minnesota Risk Assessment.

## Containment Types and Risk

DESCRIPTION	RISK	AVAILABILITY	PRICE	NOTES
Burrito Wrap (1-2 sheets 6 mil poly)	High	Low	\$50	Similar thickness and layering as EnviroZone - leakage likely.
EnviroZone Liner + Drawstring	High	Low - Medium	\$200	Based on field observations, these were punctured by beaks, feet, and wings. The transport risk assessment stated these would be equal to BIO-ZIP bags, assuming they didn't leak. Given that they leaked, they're considered inferior to BBIO-ZIP bags.
BIO-ZIP Bag	Low	Medium	\$450	Based on field observations, the first load of BIO-ZIP bags were moved to the Tarmac Unit, and there were no leaks.
Macrovault	Very Low	Low - Medium	\$1,400	Limited supply of rendering trucks.

LPMiller, USDA, 2015.

## HPAI Outbreak 2014-2015

## Safety, Health, &amp; Environmental Protection

May 20, 2015

*Note: These procedures may be revised as the situation develops.*



### Quick Response Card

**Ensuring responder safety is the first priority at all times:**

**A**lways know the hazards of the job, and how to protect yourself – read the SOP.

**B**uddy system – know where your buddy is during on-farm activities.

**C**are – take care of yourself – PPE, rest breaks, water, food, cool off.

**D**efensive Driving – seat belts, no use of any communications devices while driving.

Carry a vehicle accident kit and a first aid kit.

**E**AP – Employee Assistance Program – (800) 222-0364 (24 hrs/day, 7 days/week).

**F**atigue – get plenty of rest and sleep – don't drive when you're tired.

**G**et the Standard Operating Procedures (SOP) – read them and understand them.

- Program phone numbers for your Incident Supervisor and the Safety Officer into your phone.
- Make sure Location Services is enabled on your phone.
- Know the location of the nearest hospital.

**SEE YOUR SAFETY OFFICER OR INCIDENT SUPERVISOR FOR MORE INFORMATION ON:**

- Heat stress
- Rest breaks – take them!
- Accident/injury/illness reporting
- Workers' Compensation (OWCP)
- Check-out/check-in procedures
- Respirator use
- Weather
- Chemical safety
- Medical clearance
- Respirator training and fit testing
- Personal protective equipment (PPE)
- Daily briefing
- Incident action plan
- Emergency procedures
- Uncooperative individuals
- Standard operating procedures

## OTHER IMPORTANT STUFF

- Tell your Incident Supervisor or Safety Officer immediately if you're injured or feel sick.
- Report hazards immediately.
- Don't work more than 12 hours without specific supervisor instructions.
- Take breaks at least every 2 hours to cool off and drink fluids.
- If your urine is yellow, drink more water.
- Watch for weather, ticks, mosquitos, dogs, deer on the highways, hostile owners.
- Practice biosecurity: prevent contamination, clean, disinfect.
- Watch your step - booties can be slippery.
- Campylobacteriosis and salmonellosis are among the zoonotic diseases of concern when working with poultry. Wash hands with soap after contact with animal feces. Consume all food and water on the clean side of the clean/dirty line.
- Don't enter barns during/after CO2 operations until Incident Supervisor or safety officer declares it's safe. Stay out of foam during foaming operations.
- Shower and shampoo as soon as possible. Clean and disinfect the vehicle before leaving infected premises, and wash the vehicle after leaving the premises.
- Biosafety is very important, but don't forget about other hazards: electrical, machinery/vehicles, enclosed spaces/tanks/silos/pits, chemicals including disinfectants/detergents, high-pressure sprayers, ammonia, walking and working surfaces.
- Wear visible ID while conducting surveillance.
- Wash hands frequently. Don't share food or drink.
- Try to get a healthy diet. Minimize alcohol intake, especially in hot weather. Build up heat resistance over a period of several days.

## PERSONAL PROTECTIVE EQUIPMENT (PPE)

- Wear PPE for the job you are doing. Don't remove your PPE until you're back at the clean/dirty line. Full PPE is required for work done on infected premises:
  - Tyvek coveralls (Tychem coveralls for foam depopulation)
  - Rubber boots or boot covers
  - N95 respirators as a minimum
  - Safety goggles or safety glasses with sideshields
  - Gloves (double) (e.g., inner latex gloves; outer glove)
  - Head bonnet and/or hardhat
  - Hearing protection (disposable ear plugs) where noise is a hazard
- What to do if your PPE is breached or compromised:
  - If your PPE is breached (torn or obviously damaged), take your buddy with you and leave the work area, doff PPE, decontaminate yourself, and don new PPE. A minor tear might be "fixable" with duct tape after you've used alcohol gel on your skin. If your skin was cut or scraped, you should shower, then apply first aid. Let your Incident Supervisor know as soon as you can, but at least by the end of your shift.
  - If you think your PPE is compromised (possibly damaged or not working properly) at any time when working,, stop working immediately. Contact your Incident Supervisor and/or the Safety Officer for guidance. If this requires leaving the work area, take your buddy with you.

## MORE ON THE BUDDY SYSTEM

- While in the Hot or Exclusion Zone, use the buddy system. Work in pairs and stay in close visual contact and summon rapid assistance in case of an emergency. The responsibilities of workers using the buddy system include:
  - remaining in close visual contact with your partner,
  - providing your partner with assistance as needed or requested,
  - watching your partner for signs of heat stress or other difficulties,
  - periodically checking the integrity of your partner's PPE, and
  - notifying the site manager or other site personnel if emergency assistance is needed.

*All responders must follow safety and health guidelines to protect themselves and everyone around them. You risk more than your own health and safety, as well as biosecurity, if you do not.*



APHIS Emergency Mobilization Guide, APHIS 1050, March 3, 2014  
[https://www.aphis.usda.gov/library/manuals/pdf/aphis\\_1050.pdf](https://www.aphis.usda.gov/library/manuals/pdf/aphis_1050.pdf)



Highly Pathogenic Avian Influenza Standard Operating Procedures: 8. Health and Safety & Personal Protective Equipment, FADPReP, USDA APHIS, January 2014  
[https://www.aphis.usda.gov/animal\\_health/emergency\\_management/downloads/sop/sop\\_hpai\\_health\\_safety.pdf](https://www.aphis.usda.gov/animal_health/emergency_management/downloads/sop/sop_hpai_health_safety.pdf)



Highly Pathogenic Avian Influenza Response Plan -- The Red Book, FADPReP, USDA APHIS, September 2012  
[https://www.aphis.usda.gov/animal\\_health/emergency\\_management/downloads/hpai\\_response\\_plan.pdf](https://www.aphis.usda.gov/animal_health/emergency_management/downloads/hpai_response_plan.pdf)

Quick Response (QR) codes require a Smartphone with an enabled app – recommend “RedLaser Barcode Scanner.”

USDA HPAI website ([go.usdatraining.com/HPAI](http://go.usdatraining.com/HPAI)).

# Personal Protective Equipment

Disposal personnel (equipment operators, drivers, contractors) must be briefed on safety requirements, appropriate PPE, site conditions, and tasks by their supervisor and/or designated safety officer. The PPE outlined in this section is an example; actual PPE may vary based on tasks.

**IMPORTANT PPE FUNCTIONS**

- Protects user from exposure to potentially life-threatening infectious agents.
- Prevents spread of biological hazards by the user.

All personnel are responsible for understanding how to use PPE appropriately to prevent the transmission of disease.

For donning PPE and other health and safety needs, see:

- FAD site-specific health and safety plan
- NAHEMS Guidelines: Health and Safety: [go.usdatraining.com/NAHEMS\\_Safety](http://go.usdatraining.com/NAHEMS_Safety)
- NAHEMS Guidelines: PPE: [go.usdatraining.com/NAHEMS\\_PPE](http://go.usdatraining.com/NAHEMS_PPE)
- Standard Operating Procedures: Health and Safety & PPE: [go.usdatraining.com/SOP\\_PPE](http://go.usdatraining.com/SOP_PPE)

## PPE OPTIONS

To reduce the risk of exposure to disease, it is important that you wear the proper PPE.

TO PROTECT	HEAD	EYE	HAND	FOOT	SKIN	RESPIRATORY
	PPE PROTECTION LEVEL FROM LESS TO MORE	 Hard hat	 Safety goggles	 Latex or nitrile gloves	 Washable rubber over-boots	 Disposable Tyvek™ suit
 Hair cover or hood			 Thick rubber gloves	 Disposable plastic boot covers	 Impermeable apron	 Powered air-purifying respirator (PAPR)
					 Chemical-resistant tape	

Developed by Texas A&M University ([go.usdatraining.com/investigation](http://go.usdatraining.com/investigation)).

# PPE Requirements

## APPROPRIATE PPE

**EYE:** non-vented eye goggles, indirectly vented eye goggles with anti-fog coating, or alternative respirator with full face piece

**RESPIRATORY:** N95 APR or PAPR (highly strenuous work/exposure)

Disposable latex or nitrile gloves or thick rubber gloves + chemical-resistant tape



## CLEAN UP

- Dispose of PPE (except non-disposable items like PAPR blower/filters)
- Disinfect boots
- Wash hands
- Shower

## PPE PROCEDURE VIDEOS

The following videos depict proper procedures for the donning and doffing of PPE in both assisted and unassisted scenarios. To view the videos on a mobile device, scan the graphic code below with a QR code reader. The videos can also be accessed at [www.usdatraining.com/ppe](http://www.usdatraining.com/ppe)



## Go-Bag Checklist

Below is a list of PPE and other biosecurity items that individuals deploying to an animal disease outbreak response may want to have upon arrival at an incident. The quantities are sufficient for 1 to 2 days, unsupported by a centralized supply point.

ITEM	QUANTITY	COMMENTS
<input type="checkbox"/> Large duffel bag	1	12 in. x 12 in. x 36 in. minimum, wheels optional. High visibility, waterproof, durable with luggage tag.
<b>PPE</b>		
<input type="checkbox"/> Tyvek coveralls	10	Hooded with elastic wrists and ankles. At least one per farm visit. Other coveralls made from non-woven spunbond Olefin fiber, plain or vinyl coated like Tychem, can be substituted.
<input type="checkbox"/> Duct tape	1 roll	Keep in mind some brands of duct tape have poor adhesive qualities in cold weather.
<input type="checkbox"/> Hard hat with ratchet	1	
<input type="checkbox"/> Head lamp flashlight with batteries	1	
<input type="checkbox"/> Respirator (N95 equivalent minimum)	10	Respirator model must correspond to fit test card.
<input type="checkbox"/> Goggles		
<input type="checkbox"/> Face protection (shield)	1	Provides secondary protection of face/mucous membranes from exposure to pathogens.
<input type="checkbox"/> Fog Fixer towelettes		
<input type="checkbox"/> Eyewear cleaning wipes		
<input type="checkbox"/> Nitrile gloves	20	2 pair per expected farm visit. Double gloves required.
<input type="checkbox"/> Hearing protection		As needed.
<b>CLEANING AND DISINFECTION</b>		
<input type="checkbox"/> Surgical scrub brush and nail cleaner with Chlorhexidine Gluconate and water	20	
<input type="checkbox"/> Disinfecting wipes	Enough for 10 farm visits	Ensure wipes are labeled for pathogen of concern and follow instructions for use on label.
<input type="checkbox"/> Spray disinfectant		Aerosol sprays greater than 100ml cannot be transported on domestic airlines. Can only transport powdered or pelleted disinfectants by air in original packaging. Most common is Lysol or Techrol brands. May be simpler to purchase after deployment arrival. See the USDA-APHIS Registered Antimicrobial Products with Label Claims for specific pathogen: <a href="http://go.usdatraining.com/Disinfectants">go.usdatraining.com/Disinfectants</a>
<input type="checkbox"/> Trash bags	1 box 13 gal. drawstring 1 box 30 gal. contractor	For collection of biosecure trash within the vehicle. Drawstring bags are easiest to use due to size. One to two large contractor bags for double bagging prior to disposal into biosecure trash on site.
<input type="checkbox"/> Pens, pencils, sharpie pens	2 of each	
<input type="checkbox"/> Hand sanitizer		

ITEM	QUANTITY	COMMENTS
<b>DOCUMENTATION</b>		
<input type="checkbox"/> Proof of fit test	1 each	Hard and digital copy. Must be re-fit tested annually.
<input type="checkbox"/> Proof of physical fitness	1 each	Hard and digital copy of letter from doctor. Must be renewed at interval specified in letter.
<input type="checkbox"/> ID card lanyard	1	Necessary to hold the issued USDA ID while working on site.
<input type="checkbox"/> USDA SOPs and job aids	As desired	Hardcopy, laminated hardcopy, and digital copies can be brought at the rate desired.
<input type="checkbox"/> Flash drive with all required docs and reporting forms	1	
<b>OPTIONAL ITEMS</b>		
<input type="checkbox"/> Carabiner or "S-Biner"	1	Secures rental car keys to belt loop inside Tyvek overalls.
<input type="checkbox"/> Light gloves (cotton or other light work type)	5 to 10 pair	Can be substituted as outer glove in the double glove scheme.
<input type="checkbox"/> Cooling vest if working in hot conditions		
<input type="checkbox"/> Bouffant (hair net)	5 to 10 as a minimum	Required head cover when using Tyvek coveralls without a hood. Bouffants can also be used as a lens or screen drying or cleaning tool.
<input type="checkbox"/> Hand-pumped spray bottle	1	For use in mixing with water and spraying dry disinfectant if needed.
<input type="checkbox"/> Shoe cover	10 to 20	Shoe covers may be worn between the removal of disinfectable inner boot at rear of vehicle and entry into driver's seat as a way to minimize contamination of the inside of the car.
<input type="checkbox"/> Hoof pick on a lanyard	1	Attached to belt loop inside Tyvek overalls. If using multiuse disinfectable inner boots, hoof pick can be used to clean out the lugs of the boot heel and sole at transfer from Hot Zone to Warm Zone.
<input type="checkbox"/> Ziplock storage bags	10 to 20	To keep phone "clean" while in the Hot Zone
<input type="checkbox"/> Small inverter	1	To provide AC power for computer use in vehicle on site.
<input type="checkbox"/> Accordion file	1	For organizing paperwork
<input type="checkbox"/> Yard spray bottle	1	For spraying GOV and other large items
<input type="checkbox"/> Disinfecting wipes		



# Temporary Vehicle Wash Station

## Draft Standard Operating Procedure

April 2015

### MATERIALS CHECKLIST (Approximate total = \$850)

ITEM	QUANTITY	COST	COMMENTS
<input type="checkbox"/> Large heavy-duty tarp	1	\$120	20'x30' heavy duty from Home Depot or similar.
<input type="checkbox"/> Swimming pool noodles	10	\$80	9 4-inch diameter from Home Depot or similar.
<input type="checkbox"/> Submersible sump pump	1	\$190	With bottom intake and discharge hose. 1/2 HP submersible from Home Depot or similar
<input type="checkbox"/> Basket strainer	1		(see photo 2)
<input type="checkbox"/> Back-pack chemical sprayer	2	\$270 ea.	Example: <a href="http://go.usdatraining.com/sprayer">go.usdatraining.com/sprayer</a> or similar
<input type="checkbox"/> 10-pound pail Virkon S	1	\$70	
<input type="checkbox"/> Pressure washer detergent	1	\$15	
<input type="checkbox"/> Heavy-duty 32-gal plastic trash cans	2	\$30 ea.	One for storing supplies and one for collecting wash water.
<input type="checkbox"/> 24-inch push broom with telescoping handle	1	\$35	
<input type="checkbox"/> Long-handled scrub brushes	2	\$5 ea.	
<input type="checkbox"/> PPE			Based on site safety plan and hazard analysis - see Safety Officer
<input type="checkbox"/> Water supply			
<input type="checkbox"/> Discharge container			Secure properly licensed contractor for removal or written permission from jurisdiction to discharge to sanitary or storm sewer



1 Temporary vehicle wash station set-up.



2 Sump pump in bucket strainer.

## PROCEDURE

1. Select a location with flat or gently sloping topography for the vehicle wash station which is between the infected zone and the exit.
2. Spread tarp on the ground.
3. Place swimming pool noodles under tarp around entire perimeter. Roll edges of tarp around noodles to promote drainage ([see photo 1](#)).
4. Place sump pump in bucket strainer on tarp at low end where water is collecting ([see photo 2](#)). Connect pump electrical cord to power outlet. Direct discharge hose to collection container or approved sanitary sewer drain (not storm sewer).
5. If using 55-gallon drums or trash cans to collect wash water, place empty containers on/in haul vehicle before filling, then pump water to container on/in truck rather than filling the container on the ground then trying to lift full container later.
6. Fill sprayers with cleaning/disinfecting solution(s). *NOTE: Up to 40% propylene glycol antifreeze can be mixed with water before preparing solutions (for sub-freezing temperatures).*
7. Drive vehicle onto tarp.
8. Wash vehicle with cleaning solution, taking extra care on tires and wheel wells, scrubbing with scrub brushes as necessary. *NOTE: Tarp will be extremely slippery – use rubber overboots with good traction.*
9. Use long-handled broom to push accumulating liquid towards sump pump as needed.
10. Rinse vehicle with clean water.
11. Apply disinfectant if using separate disinfection step. Ensure full wetted contact time (foam formulations are easier in this regard).
12. Rinse vehicle with clean water.
13. Drive vehicle off tarp towards the exit. Do not allow vehicle to drive back into infected area prior to exiting.
14. At end of operation, wash both sides of tarp, rinse with clean water, and allow tarp to dry before storing.
15. Dispose of collected wash water in accordance with jurisdiction WRITTEN instructions. Alternately, hire properly licensed local waste hauler to remove waste water.

# Work Zones and Control Areas

Identifying and designating work zones in the area of operations, and control areas on premises, may help prevent the transmission of the disease.

## EXEMPLARY BIOSECURITY FUNCTIONS

- Protect general public and people involved
- Prevent further disease spread
- Contain the infectious agent

*All personnel entering the site must:*

- Meet security requirements as established by the Incident Command.
- Present documentation of verified credentials showing they are qualified to perform their assigned tasks,
- Present documentation that they have received all required briefings as defined in the site-specific Incident Action Plan
- Wear the required PPE specified in the site-specific Incident Action Plan  
See *Standard Operating Procedures: Health and Safety & PPE*: [go.usdatraining.com/SOP\\_PPE](http://go.usdatraining.com/SOP_PPE)
- Follow all Biosecurity procedures specified in the site-specific Incident Action Plan  
See *NAHEMS Guidelines: Biosecurity*: [go.usdatraining.com/NAHEMS\\_Biosecurity](http://go.usdatraining.com/NAHEMS_Biosecurity) and  
*Standard Operating Procedures: Biosecurity*: [go.usdatraining.com/SOP\\_Biosecurity](http://go.usdatraining.com/SOP_Biosecurity)

## WORK ZONES

Work zones are small areas that only apply to specific premises:

- Exclusion Zone (EZ)/Red Zone/Hot Zone
- Contamination Reduction Zone (CRZ)/Yellow Zone/Warm Zone
- Support Zone (SZ)/Green Zone/Cold Zone

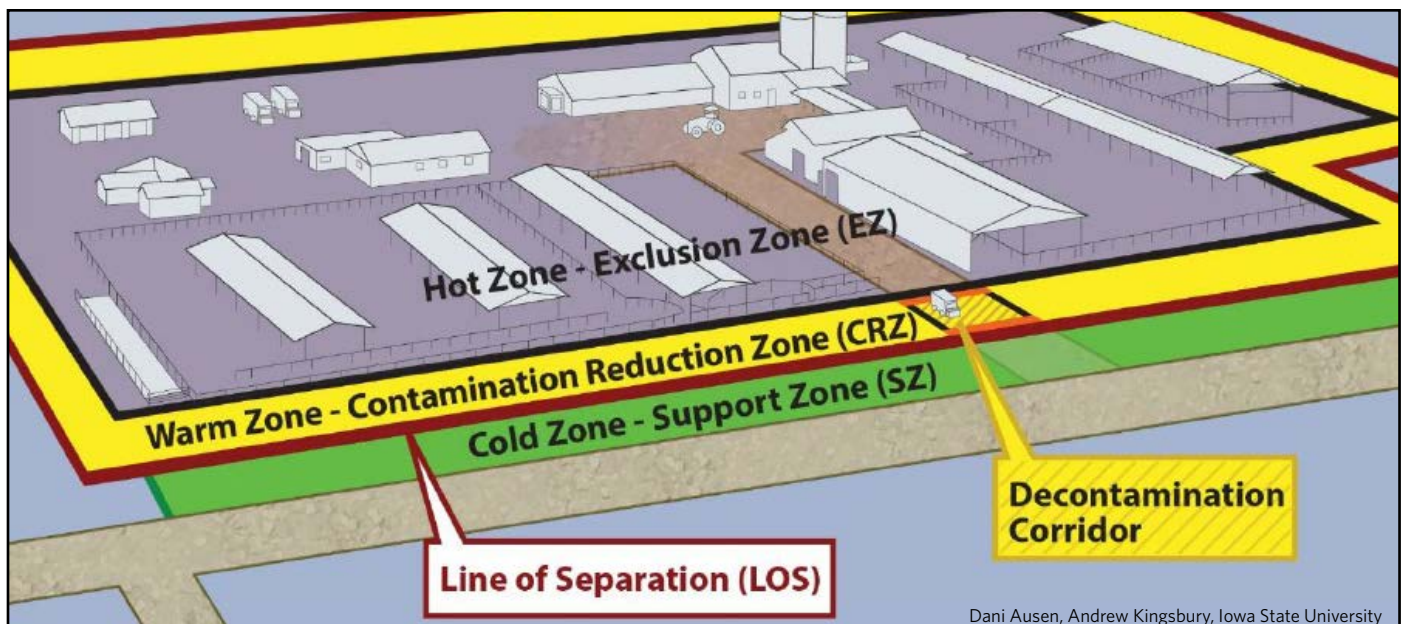

Dani Ausen, Andrew Kingsbury, Iowa State University

Adapted from FADPrep Disposal Guidelines.

## Best Practices for Managing Contamination Reduction Zone (CRZ)

### 1. Set Up the CRZ

- Set up the CRZ to allow personnel to enter/exit the zone without risk of contamination.
- Establish a decontamination corridor for personnel/PPE .
- Designate a place for emergency decontamination.
- Create a slightly-sloped impervious surface that facilitates disinfectant collection, such as a plastic ground cover at least 10 x 10 meters .
- Provide a water supply and collection system.
- Verify that run-off water is collected or flows back into the Exclusion Zone (EZ).

### 2. Coordinate Movement through the CRZ

- Monitor and enforce entry and exit into the CRZ via one or two sites for authorized personnel working in the secured EZ.
- Create four enclosed areas to allow for doffing PPE.
- Secure all other possible entrances.

## THE DECONTAMINATION CORRIDOR

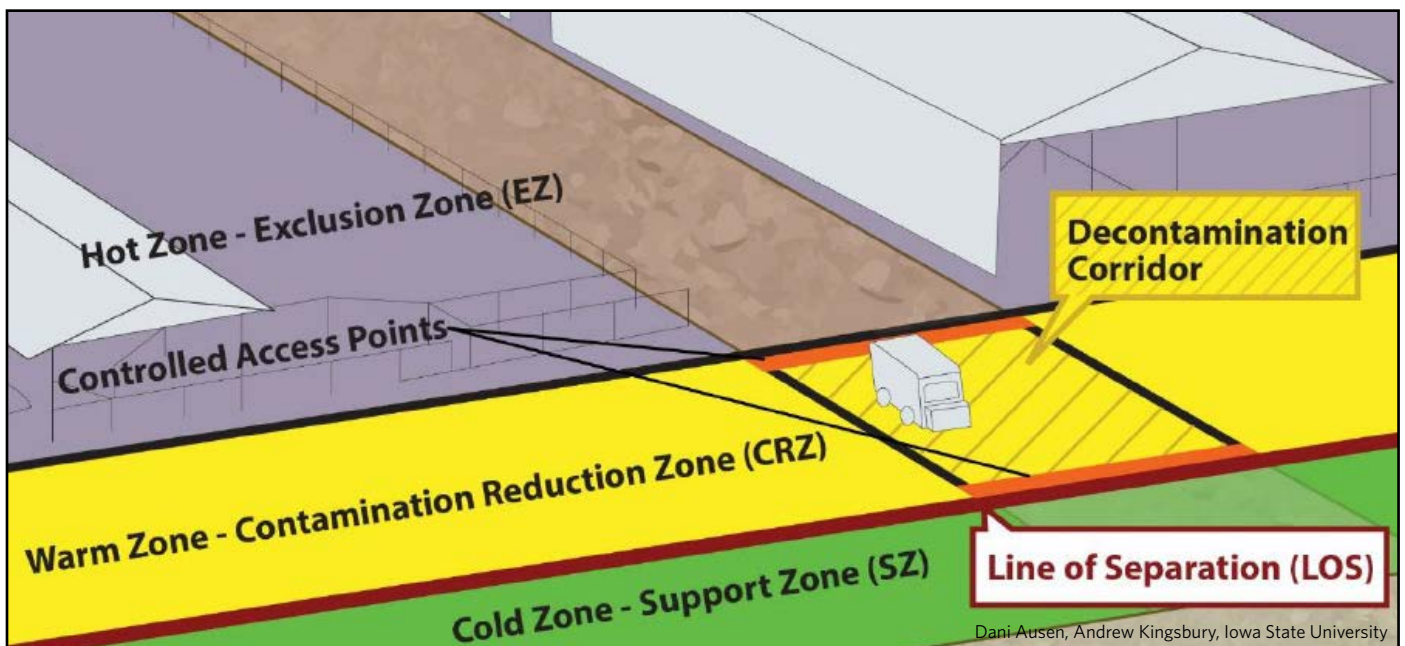

## BIOSECURITY IN THE DECONTAMINATION CORRIDOR

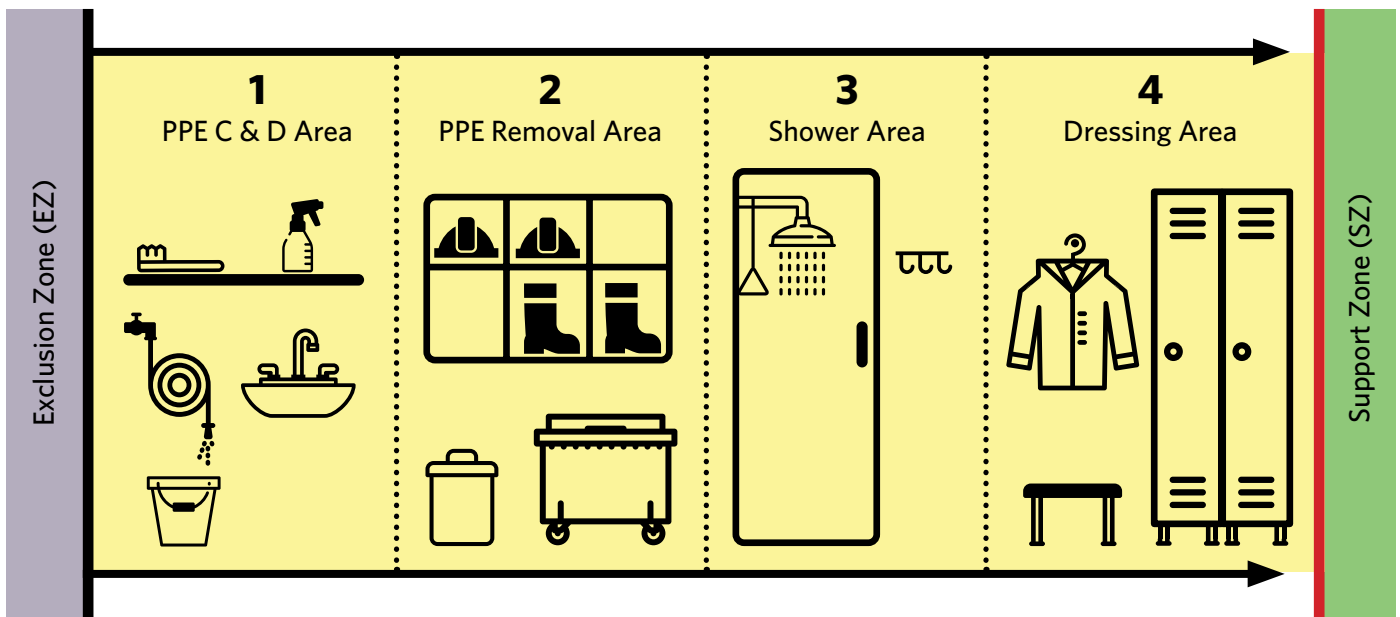
**Area 1: PPE Cleaning & Disinfecting Area**

- Use a washing station supplied with water and disinfectants
- Scrub or spray-off exterior protective clothing
- Thoroughly wash boots, coveralls, and gloved hands

**Area 2: PPE Removal Area**

- Always remove protective clothing first and discard or secure the clothing for disinfection
- Remove respirators and goggles
- Remove gloves last, by turning gloves inside out and using one gloved hand to remove the other glove
- Place clothing and equipment in prepared bins for disposal or cleaning
- Properly discard disposable items as infectious waste in accordance with all applicable regulations
- Clean/disinfect non-disposable items

**Area 3: Shower Area**

- Enter showering facilities if available
- Wash hair and all body surfaces
- If no showering facilities are available, proceed to dressing area

**Area 4: Dressing Area**

- Wash hands and face
- Change into clean clothing

**CONTROL AREAS**

Control areas, in comparison to the smaller work zones areas, are another means of preventing disease transmission by monitoring movement around the quarantine zone. The quarantine zone may be miles in diameter and may include many premises. For more information on control areas see the [Ready Reference Guide—Zones, Areas, and Premises in an FAD Outbreak](#)

For more information see *Feed Delivery Biosecurity for Control of Disease*: [go.usdatraining.com/Feed\\_delivery](http://go.usdatraining.com/Feed_delivery)

# Ready Reference Guide—Overview of Zones

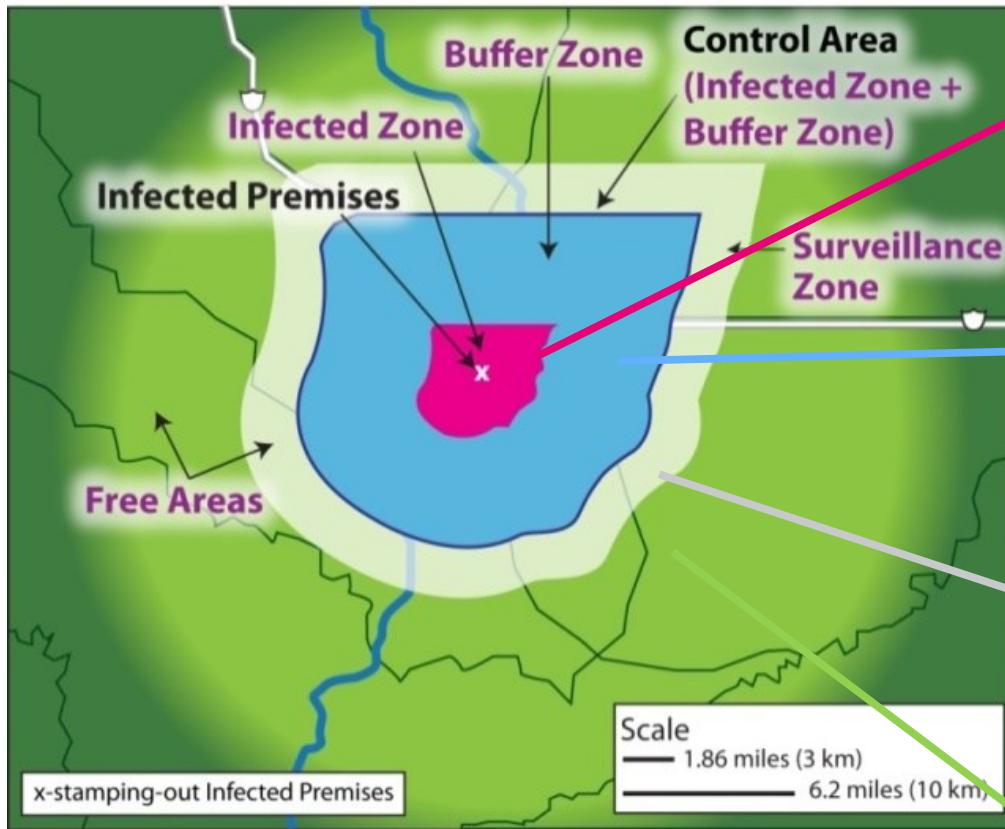

In the **Infected Zone** (which is *part of the Control Area*), there are movement controls and surveillance activities. Infected Premises are quarantined.

In the **Buffer Zone** (which is *part of the Control Area*), there are movement controls and surveillance activities.

In the **Surveillance Zone** (which is *part of the Free Area*), targeted poultry surveillance may be conducted (i.e. commercial premises).

In the **Free Area** (which *includes the Surveillance Zone*), routine or program surveillance may occur (i.e. NPIP and wild birds).

■ Infected Zone      ■ Buffer Zone      ■ Surveillance Zone  
■ + ■ = Control Area      ■ + ■ = Free Area

Zone/Area	Definition
Infected Zone (IZ)	Zone that immediately surrounds an Infected Premises.
Buffer Zone (BZ)	Zone that immediately surrounds an Infected Zone or a Contact Premises.
Control Area (CA)	Consists of an Infected Zone and a Buffer Zone.
Surveillance Zone (SZ)	Zone outside and along the border of a Control Area. The Surveillance Zone is part of the Free Area.
Free Area (FA)	Area not included in any Control Area. Includes the Surveillance Zone.



Infected, Contact, and Suspect Premises are subject to individual premises quarantines.  
 At-Risk and Monitored Premises are subject to movement control restrictions.

### Summary of Premises Designations

Premises	Definition	Zone
Infected Premises (IP)	Premises where a presumptive positive case or confirmed positive case exists based on laboratory results, compatible clinical signs, case definition, and international standards.	Infected Zone
Contact Premises (CP)	Premises with susceptible animals that may have been exposed to the FAD, either directly or indirectly, including but not limited to exposure to animals, animal products, fomites, or people from Infected Premises.	Infected Zone, Buffer Zone
Suspect Premises (SP)	Premises under investigation due to the presence of susceptible animals reported to have clinical signs compatible with the FAD. This is intended to be a short-term premises designation.	Infected Zone, Buffer Zone, Surveillance Zone, Vaccination Zone
At-Risk Premises (ARP)	Premises that have susceptible animals, but none of those susceptible animals have clinical signs compatible with the FAD. Premises objectively demonstrates that it is not an Infected Premises, Contact Premises, or Suspect Premises. At-Risk Premises may seek to move susceptible animals or products within the Control Area by permit. Only At-Risk Premises are eligible to become Monitored Premises.	Infected Zone, Buffer Zone
Monitored Premises (MP)	Premises objectively demonstrates that it is not an Infected Premises, Contact Premises, or Suspect Premises. Only At-Risk Premises are eligible to become Monitored Premises. Monitored Premises meet a set of defined criteria in seeking to move susceptible animals or products out of the Control Area by permit.	Infected Zone, Buffer Zone
Free Premises (FP)	Premises outside of a Control Area and not a Contact or Suspect Premises.	Surveillance Zone, Free Area
Vaccinated Premises (VP)	Premises where emergency vaccination has been performed. This may be a secondary premises designation.	Containment Vaccination Zone, Protection Vaccination Zone

### Example Zones, Areas, and Premises

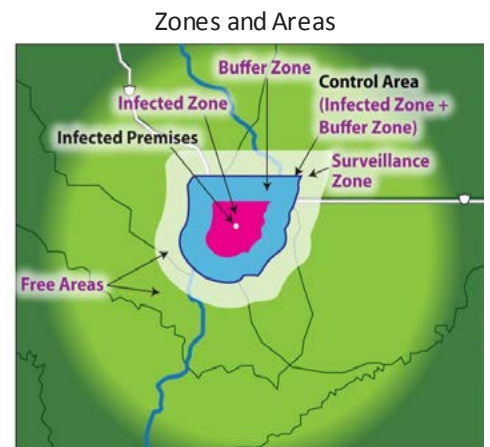

Note: Figures are not to scale.

- Infected Zone
- Buffer Zone
- Surveillance Zone
- +  = Control Area
- +  = Free Area

### Summary of Zone and Area Designations

Zone/Area	Definition
Infected Zone (IZ)	Zone that immediately surrounds an Infected Premises.
Buffer Zone (BZ)	Zone that immediately surrounds an Infected Zone or a Contact Premises.
Control Area (CA)	Consists of an Infected Zone and a Buffer Zone.
Surveillance Zone (SZ)	Zone outside and along the border of a Control Area. The Surveillance Zone is part of the Free Area.
Free Area (FA)	Area not included in any Control Area. Includes the Surveillance Zone.
Vaccination Zone (VZ)	Emergency Vaccination Zone classified as either a Containment Vaccination Zone (typically inside a Control Area) or a Protection Vaccination Zone (typically outside a Control Area). This may be a secondary zone designation.

In an HPAI outbreak, the Incident Commander will work with the Operations Section and Planning Section to determine the appropriate designations.

## Factors Used to Determine Control Area Size

Factors	Additional Details
Jurisdictional areas	<ul style="list-style-type: none"> <li>Effectiveness and efficiency of administration</li> <li>Multi-jurisdictional considerations: local, State, Tribal, and multistate</li> </ul>
Physical boundaries	<ul style="list-style-type: none"> <li>Areas defined by geography</li> <li>Areas defined by distance between premises</li> </ul>
FAD epidemiology	<ul style="list-style-type: none"> <li>Reproductive rate</li> <li>Incubation period</li> <li>Ease of transmission</li> <li>Infectious dose</li> <li>Species susceptibility</li> <li>Modes of transmission (such as, fecal-oral, droplet, aerosol, vectors)</li> <li>Survivability in the environment</li> <li>Ease of diagnosis (for example, no pathognomonic signs; requires diagnostic laboratory testing)</li> <li>Age of lesions</li> </ul>
Infected Premises characteristics	<ul style="list-style-type: none"> <li>Number of contacts</li> <li>Transmission pathways and transmission risk               <ul style="list-style-type: none"> <li>Extent of animal movement                   <ul style="list-style-type: none"> <li>Number of animals</li> <li>Species of animals</li> </ul> </li> </ul> </li> <li>Age of animals</li> <li>Movement of traffic and personnel to and from premises (fomite spread)</li> <li>Biosecurity measures in place at time of outbreak</li> </ul>
Contact Premises characteristics	<ul style="list-style-type: none"> <li>Number and types of premises</li> <li>Susceptible animal populations and population density</li> <li>Animal movements</li> <li>Movement of traffic (fomites) and personnel to and from premises (fomite spread)</li> <li>Biosecurity measure in place prior to outbreak</li> </ul>
Environment	<ul style="list-style-type: none"> <li>Types of premises in area or region</li> <li>Land use in area or region</li> <li>Susceptible wildlife and population density</li> <li>Wildlife as biological or mechanical vectors</li> </ul>
Climate (for aerosol spread diseases)	<ul style="list-style-type: none"> <li>Prevailing winds</li> <li>Humidity</li> </ul>
General area, region, or agricultural sector biosecurity	<ul style="list-style-type: none"> <li>Biosecurity practices in place prior to outbreak</li> <li>Biosecurity practices implemented once outbreak detected</li> </ul>
Number of backyard or transitional premises	<ul style="list-style-type: none"> <li>Types of premises, animal movements, and network of animal and fomite movements</li> </ul>
Continuity of business	<ul style="list-style-type: none"> <li>Continuity of business plans and processes in place or activated at beginning of outbreak (such as surveillance, negative diagnostic tests, premises biosecurity, and risk-assessments)</li> <li>Permit processes, memorandums of understanding, and information management systems in place or activated at beginning of outbreak</li> </ul>

## Minimum Sizes of Zones and Areas

Zone or Area	Minimum Size and Details
Infected Zone (IZ)	Perimeter should be at least 3 km (~1.86 miles) beyond perimeters of presumptive or confirmed Infected Premises. Will depend on disease agent and epidemiological circumstances. This zone may be redefined as the outbreak continues.
Buffer Zone (BZ)	Perimeter should be at least 7 km (~4.35 miles) beyond the perimeter of the Infected Zone. Width is generally not less than the minimum radius of the associated Infected Zone, but may be much larger. This zone may be redefined as the outbreak continues.
Control Area (CA)	Perimeter should be at least 10 km (~6.21 miles) beyond the perimeter of the closest Infected Premises. Please see the table above for factors that influence the size of the Control Area. This area may be redefined as the outbreak continues.
Surveillance Zone (SZ)	Width should be at least 10 km (~6.21 miles), but may be much larger.

For more information, please go to: [www.aphis.usda.gov/fadprep](http://www.aphis.usda.gov/fadprep).

For more details on zones and premises designations, please see the *APHIS FAD Framework: Response Strategies (Manual 2-0)*: [go.usdatraining.com/FADPreP\\_Manual\\_2](http://go.usdatraining.com/FADPreP_Manual_2)

For the *HPAI Response Plan: The Red Book* see: [go.usdatraining.com/HPAI\\_red\\_book](http://go.usdatraining.com/HPAI_red_book)

For the Secure Egg Supply Plan see [www.secureeggssupply.com](http://www.secureeggssupply.com)

Ready Reference Guide—Zones, Areas, and Premises in an FAD Outbreak ([go.usdatraining.com/zones](http://go.usdatraining.com/zones)).



## Stop Avian Influenza Outbreaks

**Author/Organization:** USDA APHIS

**Overview:** Highly pathogenic avian influenza (HPAI) requires a swift and efficient response. This guide outlines best practices when interacting with pathogenic diseases such as avian influenza as well as the ten steps necessary for detection, appraisal, management, elimination, and maintaining biosecurity of not only pathogenic avian influenza but also other highly pathogenic diseases.

**Direct Access:** Visit the USDA APHIS site: [go.usdatraining.com/HPAI\\_guide](https://go.usdatraining.com/HPAI_guide)

Animal and Plant Health Inspection Service  
U.S. DEPARTMENT OF AGRICULTURE

### Stop Avian Influenza Outbreaks

#### FIND Detect, report, and confirm the disease

<p>See signs of illness.</p> 	<p>Contact USDA or your State veterinarian.</p> 	<p>USDA tests samples and confirms disease.</p> 
---	--	---

#### RESPOND Quarantine, depopulate, compensate, and dispose

<p>Only authorized workers are allowed in and out; movement of birds, poultry products, and equipment is restricted.</p> 	<p>Birds are destroyed usually within 24–48 hours of detecting the disease. USDA pays for birds that must be destroyed.</p> 	<p>USDA or your State can help you dispose of dead birds.</p> 
--	---	--

#### RECOVER Clean, test, and restock

<p>Thoroughly clean and disinfect the barn, equipment, and all affected areas; no poultry allowed for 14 days.</p> 	<p>USDA collects and tests environmental samples to confirm the virus has been eliminated from your farm.</p> 	<p>You can restock your birds when USDA and your State confirm the virus is gone. You can resume normal operations when State officials release your farm from quarantine.</p> 
--	---	---

MAINTAIN BIOSECURITY Keep the disease from coming back



Learn more about stopping avian influenza:  
[aphis.usda.gov/animalhealth/defendtheflock](https://aphis.usda.gov/animalhealth/defendtheflock) • [cdc.gov/flu/avianflu](https://cdc.gov/flu/avianflu)

USDA is an equal opportunity provider, employer, and lender. This publication supersedes APHIS 91-85-005, "Highly Pathogenic Avian Influenza: A Guide To Help You Understand the Response Process," which was first published in December 2015. APHIS-22-006 | Issued April 2022

**Source:** [https://www.aphis.usda.gov/publications/animal\\_health/pos-hpai-stop-avian-influenza-outbreaks.508.pdf](https://www.aphis.usda.gov/publications/animal_health/pos-hpai-stop-avian-influenza-outbreaks.508.pdf)

# Fact Sheet 9580.202: Debris Removal

**Author/Organization:** FEMA Recovery Division

**Overview:** This fact sheet identifies and describes the authorities of federal departments and agencies in support of debris operations following a presidential emergency or major disaster declaration. The following nine Federal agencies and departments are invested with authorities addressing various aspects of debris management.

**Direct Access:** Visit the FEMA site: [Debris Removal Fact Sheet](#)



**FEDERAL EMERGENCY MANAGEMENT AGENCY**

**FEDERAL RECOVERY DIVISION**

**FACT SHEET**

**9580.202**

**DEBRIS REMOVAL**

**AUTHORITIES OF FEDERAL AGENCIES**

Overview

This fact sheet identifies and describes the authorities of federal departments and agencies in support of debris operations following a presidential emergency or major disaster declaration. The following nine Federal agencies and departments are invested with authorities (described in detail below) addressing various aspects of debris management.

- Department of Homeland Security
  - Federal Emergency Management Agency
  - United States Coast Guard
- Department of Defense: *U.S. Army Corps of Engineers*
- Department of Agriculture
  - Natural Resources and Conservation Service
  - Farm Service Agency
  - Animal Plant and Health Inspection Service
- Department of Transportation: *Federal Highway Administration*
- Department of Commerce: *National Oceanic and Atmospheric Administration*
- Environmental Protection Agency

Department of Homeland Security

**Federal Emergency Management Agency (FEMA)**

- FEMA is authorized in Sections 403, 407 and 502 of the Robert T. Stafford Disaster Relief and Emergency Assistance Act to provide assistance to eligible applicants to remove debris from public and private property following a Presidential disaster declaration, when in the public interest.
- Removal must be necessary to eliminate immediate threats to lives, public health and safety; eliminate immediate threats of significant damage to improved public or private property; or ensure

Prepared By: Public Assistance Branch
Page 1 of 7

RECOVERY DIVISION FACT SHEET - RP9580.202

**DEBRIS REMOVAL**

**AUTHORITIES OF FEDERAL AGENCIES**

the economic recovery of the affected community to the benefit of the community-at-large. The debris must be the direct result of the disaster and located in the disaster area, and the applicant must have the legal responsibility to remove the debris.

- FEMA will (1) reimburse applicants to remove eligible debris, or (2) through a mission assignment to another Federal agency (and upon request of the State) - provide *direct Federal assistance* when it has been demonstrated that the State and local government lack the capability to perform or contract for the requested work.
- Assistance will be cost-shared (at no less than 75% Federal and 25% non-Federal). In extreme circumstances, FEMA will provide up to 100% funding for a limited period of time.

**United States Coast Guard (USCG)**

- Under the National Contingency Plan (NCP), the USCG and Environmental Protection Agency (EPA) are responsible for providing pre-designated Federal On-Scene Coordinators (FOSCs) to conduct emergency removals of oil and hazardous materials.
- USCG is responsible for the coastal zone, and the EPA is responsible for the inland zone. The delineation between coastal and inland zones is by mutual agreement between the USCG and the EPA, and the geographic limits are indicated in Area Contingency Plans.
- Under the Comprehensive Environmental Response, Compensation, and Liability Act, or CERCLA (also known as Superfund), and the Clean Water Act, USCG has the authority to respond to actual or potential discharges of oil and actual or potential releases of hazardous substances, pollutants and contaminants that may endanger public health or the environment.
- Response actions may include containment, stabilization, decontamination, collection (e.g., orphan drums tanks and drums), and final disposal. Debris may be mixed with, or contain, oil or hazardous materials that are subject to USCG response authorities. Oil removal is funded from the Oil Spill Liability Trust Fund, while hazardous materials removal is conducted using CERCLA funds.
- USCG, under the Ports and Waterways Safety Act (33 U.S.C. §§1221), is responsible for keeping waterways safe and open. While there is no specific language stating that the USCG is responsible for debris removal from waterways, the USCG has been tasked - in the past - to assist in waterway and marine transportation system recovery.

Prepared By: Public Assistance Branch
Page 2 of 7

**Source:** [https://www.fema.gov/sites/default/files/2020-07/fema\\_325\\_public-assistance-debris-mgmt-plan\\_Guide\\_6-1-2007.pdf](https://www.fema.gov/sites/default/files/2020-07/fema_325_public-assistance-debris-mgmt-plan_Guide_6-1-2007.pdf)

# National Veterinary Stockpile Ready for Animal Disease Emergencies

**Author/Organization:** USDA APHIS

**Overview:** The National Veterinary Stockpile (NVS) is our Nation's repository of veterinary "countermeasures" (animal vaccines, antivirals, supplies, equipment, and response support services). Simply put, it exists to provide States, tribes, and territories with the tools they need to combat an animal disease outbreak. In an animal health emergency, the response must be fast and well-coordinated to keep disease from spreading. The NVS can dispatch—within 24 hours—critical resources animal health officials need onsite.

**Direct Access:** Visit the USDA APHIS site: <http://nvs.aphis.usda.gov>

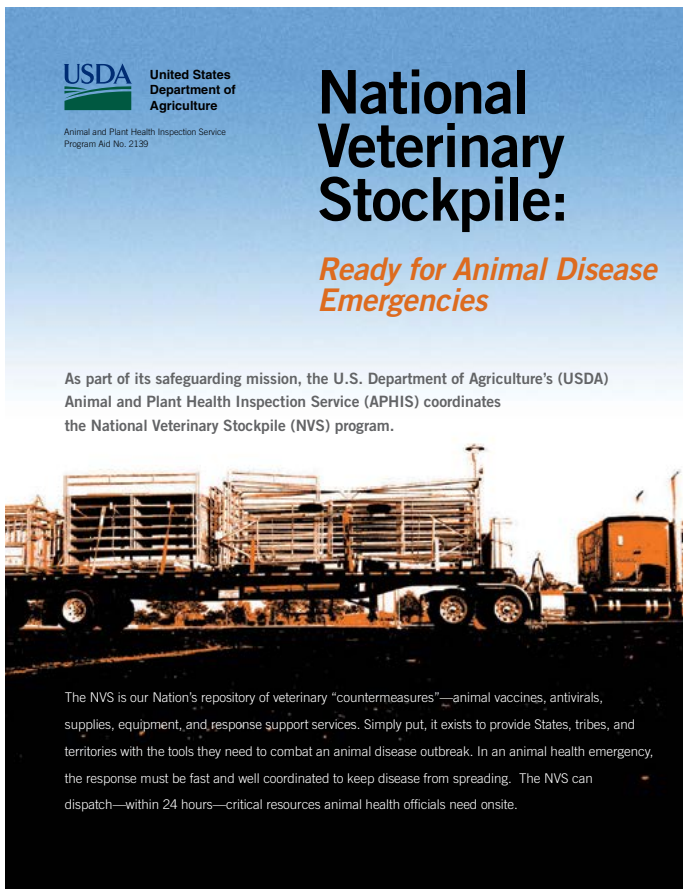

**USDA** United States Department of Agriculture  
Animal and Plant Health Inspection Service  
Program Aid No. 2139

## National Veterinary Stockpile:

### Ready for Animal Disease Emergencies

As part of its safeguarding mission, the U.S. Department of Agriculture's (USDA) Animal and Plant Health Inspection Service (APHIS) coordinates the National Veterinary Stockpile (NVS) program.

The NVS is our Nation's repository of veterinary "countermeasures"—animal vaccines, antivirals, supplies, equipment, and response support services. Simply put, it exists to provide States, tribes, and territories with the tools they need to combat an animal disease outbreak. In an animal health emergency, the response must be fast and well coordinated to keep disease from spreading. The NVS can dispatch—within 24 hours—critical resources animal health officials need onsite.

With NVS support, officials can set up immediate measures to contain and eradicate the disease, minimizing the animal losses and other economic damages that result from an outbreak. In addition to providing resources and materials when outbreaks occur, NVS personnel help States, tribes, and territories prepare for future outbreaks through careful advance planning, training, and exercises. Our goal is to make sure that, when faced with an emergency, our partners understand the process for rapidly requesting, receiving, processing, and distributing NVS resources so responders get help quickly.



#### What We Offer

##### Equipment and Supplies

The NVS offers many resources to address animal health threats during disease outbreaks. These resources (i.e., veterinary countermeasures) include:

- 1) **personal protective equipment** for on-the-ground responders to guard against infection and other onsite hazards;
- 2) **decontamination supplies** to inactivate pathogens;
- 3) **vaccines** to quickly protect livestock and poultry at risk of infection;
- 4) **vaccination equipment and supplies** (such as needles and syringes) to effectively immunize large numbers of livestock and poultry;
- 5) **animal handling equipment**, including corrals, to safely contain and restrain livestock;
- 6) **equipment for emergency euthanasia and depopulation** of animals;
- 7) **assistance in securing outside companies**, if needed, to provide trained personnel and additional equipment for large-scale depopulation, disposal, and decontamination work.

#### Training and Exercises

We help States, tribes, and territories plan for potential disease outbreaks to support a smooth response should they need NVS resources. For example, we offer a planning guide, a plan template, and other tools that explain in detail what logistical factors to consider when preparing for an agricultural emergency. Our staff can also share their first-hand experiences and expertise in handling various disease situations, which further aids the planning process.

Once a plan is in place, our staff conduct logistical training and exercises with NVS partners per the Homeland Security Exercise Evaluation Program. These exercises give participants an opportunity to:

- learn in detail about the NVS program and available resources;
- test their abilities to request, receive, process, and distribute NVS equipment, supplies, and vaccines;
- clarify roles and responsibilities to aid in a logistics operation; and
- identify resource gaps and improve response plans before outbreaks occur.



#### Contact Us

To learn more, visit our Web site at <http://nvs.aphis.usda.gov> or email us at [nvs@aphis.usda.gov](mailto:nvs@aphis.usda.gov).

You can also reach our staff by phone at (301) 851-3595 or fax at (301) 734-7817.

In an emergency, please call our 24/7 hotline: 1-800-940-6524.

USDA is an equal opportunity provider and employer.  
Issued June 2013

**Source:** [https://www.aphis.usda.gov/animal\\_health/emergency\\_management/downloads/nvs\\_factsheet.pdf](https://www.aphis.usda.gov/animal_health/emergency_management/downloads/nvs_factsheet.pdf)

# Questions and Answers: The National Veterinary Stockpile and the 24-Hour Push Pack

**Author/Organization:** USDA APHIS

**Overview:** The National Veterinary Stockpile (NVS) program, coordinated by the U.S. Department of Agriculture's (USDA) Animal and Plant Health Inspection Service (APHIS), provides support to States, Tribes, and Territories responding to damaging animal disease outbreaks. Within 24 hours, the NVS can provide veterinary countermeasures—including certain types of animal vaccines, antivirals, supplies, equipment, and response services—to animal health officials in affected areas.

**Direct Access:** Visit the USDA APHIS site: [go.usdatraining.com/NVS\\_pushpack](https://go.usdatraining.com/NVS_pushpack)



**APHIS**

**Factsheet**

Veterinary Services

March 2013

## Questions and Answers: The National Veterinary Stockpile and the 24 Hour Push Pack

The National Veterinary Stockpile (NVS) program, coordinated by the U.S. Department of Agriculture's (USDA) Animal and Plant Health Inspection Service (APHIS), provides support to States, Tribes, and Territories responding to damaging animal disease outbreaks. Within 24 hours, the NVS can provide veterinary countermeasures—including certain types of animal vaccines, antivirals, supplies, equipment, and response services—to animal health officials in affected areas. To learn more about this program, see the NVS factsheet on APHIS' Web site at [www.aphis.usda.gov/publications/animal\\_health/content/printable\\_version/veterinary\\_stockpile.pdf](http://www.aphis.usda.gov/publications/animal_health/content/printable_version/veterinary_stockpile.pdf).

One of the services NVS provides is shipping the "24 Hour Push Pack" when needed to combat a damaging animal disease outbreak.

**Q. What is a "24 Hour Push Pack?"**  
**A.** A 24 Hour Push Pack is the initial shipment of supplies. The shipment will arrive within 24 hours of APHIS' approval to deploy resources. The requester only needs to provide basic information about the situation, and we will coordinate the transport of supplies needed to respond to a damaging animal disease.

There are four details we need to determine which push pack is most appropriate for the situation:

- 1) **Type of disease**—this helps determine whether a standard or high-protection push pack is needed. High-protection push packs include high-level respiratory protection, such as Powered Air Purifying Respirators (PAPR).
- 2) **Number of responders expected**—this determines the number of push packs needed. Each push pack supports 10 responders for 10 days, changing 6 times per day. When making your request, round the number of responders up to the nearest multiple of 10.

3) **Incident command point-of-contact** to coordinate the NVS deployment

4) The **physical address of the facility** that will receive NVS supplies

Once we receive this information, the NVS Deployment Management Team will determine what to provide immediately.

**Q. What does a push pack contain?**  
**A.** Depending on the level of protection needed, there are two types of push packs.

A standard protection push pack contains four modules:

- 2 Tyvek personal protective equipment (PPE) modules, which include 450 PPE kits, a first aid kit, bulk nitrile gloves, and boot covers;
- 1 Tychem module, which includes 150 PPE kits; and
- 1 decontamination module, which contains disposable aprons, isolation bags, Ziploc® bags, long-handled brushes, buckets with covers, pop-up ultra pols, shoe and boot scrapers, EMS shears, 2-gallon sprayers, chemical tape, caution tape, and Virkon® S test strips.

A high-protection push pack contains five modules:

- 2 Tyvek PPE modules, which include 450 PPE kits, a first aid kit, bulk nitrile gloves, and boot covers;
- 1 Tychem module, which includes 150 PPE kits;
- 1 decontamination module, which contains disposable aprons, isolation bags, Ziploc bags, long-handled brushes, buckets with covers, pop-up ultra pols, shoe and boot scrapers, EMS shears, 2-gallon sprayers, chemical tape, caution tape, and Virkon S test strips; and
- 1 PAPR module, which contains the 3M™ Breathe Easy™ PAPR System.

If emergency vaccination is approved, you may also request a module containing vaccine ancillary supplies (e.g., needles, syringes, and sharps containers). In the event of a foot-and-mouth disease (FMD) outbreak, you may request a second vaccine ancillary supplies module containing pink FMD tags. This request is subject to North American FMD Vaccine Bank (NAFMDVB) approval; NVS stores the pink FMD tags for the NAFMDVB.

**Q. What sizes of PPE are included in each 24 Hour Push Pack?**  
**A.** Each PPE module contains 2XL and 3XL suits. The NVS staff determined, after careful consideration, that these two sizes fit the vast majority of responders.

**Q. Will all of the 24 Hour Push Packs arrive on one truck?**  
**A.** NVS can typically load 50 to 52 modules in one tractor trailer. This equates to 10 push packs, with the remaining 2 spaces available for possible vaccine ancillary supplies. If you require more than 10 push packs, expect more than one tractor trailer.

**Q. Do the 24 Hour Push Packs arrive on pallets?**  
**A.** The push packs are fully contained in Tri-Walls™, which consist of triple-walled, fiberboard sleeves, a plastic top, and a plastic bottom pallet. The sleeve can be locked with the bottom pallet and top to form a rigid and secure system that eliminates the requirement for banding, stretch wrap, or strapping material. They are 40 inches by 48 inches and are either 45 inches or 52 inches tall. The plastic top and bottom pallet can be removed and the sleeve folded for storage. Forklifts or pallet jacks move them easily.

**Q. How are the 24 Hour Push Packs configured? How can I quickly identify items in the pack?**  
**A.** Each 24 Hour Push Pack consists of modules that are packed with like items. This allows warehouse personnel to quickly find specific items; for example, all decontamination supplies are packed in modules that have been labeled with a number "4." We also attach a detailed packing list to the outside of each module that identifies the contents. A packing diagram for each module is included on a drop flap.

To expedite filling requests, the NVS uses the following color-coded labeling system to distinguish the contents of each module so that items can be located quickly:

- Blue = PPE
- White = decontamination supplies
- Yellow = vaccines, antivirals, and vaccination supplies
- Green = PAPR systems

**Q. Can empty modules be used to ship supplies from a storage location to a premises?**  
**A.** Empty Tri-Walls must be returned to an NVS logistics center so that they can be reused. The NVS Deployment Management Team will arrange for pickup and transport back to one of our centers.

**Q. If I have questions about the NVS, who should I contact?**  
**A.** Email us at [nvs@aphis.usda.gov](mailto:nvs@aphis.usda.gov) with any questions. More information is also available on our Web site at [www.aphis.usda.gov/animal\\_health/emergency\\_management/nvs.shtml](http://www.aphis.usda.gov/animal_health/emergency_management/nvs.shtml).

USDA is an equal opportunity provider and employer.

Mention of companies or commercial products does not imply recommendation or endorsement by the U.S. Department of Agriculture over others not mentioned. USDA neither guarantees nor warrants the standard of any product mentioned. Product names are mentioned solely to report factually on available data and to provide specific information.

United States Department of Agriculture • Animal and Plant Health Inspection Service • **Safeguarding American Agriculture**

**Source:** [https://www.aphis.usda.gov/animal\\_health/emergency\\_management/downloads/nvs\\_24hour\\_pushpacks.pdf](https://www.aphis.usda.gov/animal_health/emergency_management/downloads/nvs_24hour_pushpacks.pdf)

# Questions and Answers: The National Veterinary Stockpile and 3D Response Support Services

**Author/Organization:** USDA APHIS

**Overview:** NVS provides depopulation, disposal, and decontamination (3D) response support through a variety of contractors. These activities commonly require the rapid deployment of large numbers of response personnel and equipment. The NVS maintains contracts with all-hazards emergency response companies to assist with 3D operations as needed and serves as the single point-of-contact within APHIS for 3D response support services.

**Direct Access:** Visit the USDA APHIS site: [go.usdatraining.com/3D](https://go.usdatraining.com/3D)



**APHIS**

**Factsheet**

Veterinary Services

March 2013

## Questions and Answers: The National Veterinary Stockpile and 3D Response Support Services

The National Veterinary Stockpile (NVS) program, coordinated by the U.S. Department of Agriculture's (USDA) Animal and Plant Health Inspection Service (APHIS), provides support to States, Tribes, and Territories responding to damaging animal disease outbreaks. Within 24 hours, the NVS can provide veterinary countermeasures—including certain types of animal vaccines, antivirals, supplies, equipment, and response services—to animal health officials in affected areas. To learn more about this program, see the NVS factsheet on APHIS' Web site at [www.aphis.usda.gov/publications/animal\\_health/content/printable\\_version/veterinary\\_stockpile.pdf](http://www.aphis.usda.gov/publications/animal_health/content/printable_version/veterinary_stockpile.pdf).

NVS provides depopulation, disposal, and decontamination (3D) response support through a variety of contractors.

**Q. What are 3D response support services?**  
**A.** "3D" refers to depopulation, disposal, and decontamination activities. These activities commonly require the rapid deployment of large numbers of response personnel and equipment. The NVS maintains contracts with all-hazards emergency response companies to assist with 3D operations as needed and serves as the single point-of-contact within APHIS for 3D response support services.

**Q. What types of services can 3D contractors provide?**  
**A.** 3D response support services include:

- **surge personnel** fully equipped with personal protective equipment;
- **decontamination equipment and mobile teams** to support field responders onsite;
- **waste management and disposal**, including carcass and debris recovery, handling, and disposal;

- **hazardous and infectious material transportation** and access to landfills;
- **staging area setup** and operations for distribution of equipment and materials;
- **certified operators for special equipment**, including forklifts, skid loaders, and heavy trucks/equipment; and
- **special equipment** such as mobile command centers, emergency power and lighting, pumps/pressure washers, and satellite terminal and radio communications.

**Q. How experienced are the 3D contractors in responding to agricultural emergencies?**  
**A.** All of our 3D contractors receive annual training from NVS specific to agricultural emergency response. We design this training to ensure that our contractors are proficient—and efficient—in responding to these types of emergencies and in using NVS equipment and resources. Our contractors also participate in the NVS exercise program, which reinforces lessons learned and prepares them on an operational level for responding to agricultural emergencies.

The 3D contractors are also highly trained in all-hazards emergency response and are capable of deploying with their own equipment and supplies. They are experts in decontamination and disposal operations, including State requirements for transporting and disposing of hazardous materials. The contractors operate within the National Incident Management System.

**Q. How quickly will 3D contractors arrive onsite? What is their surge capacity?**  
**A.** The 3D contractors will arrive within 24 hours of receiving the approval to deploy and report to Incident Command. Depending on services required, the contractors can deploy approximately 600 personnel within 72 hours and 1,000 personnel within a week.

**Q. What happens if there are simultaneous events and multiple requests for 3D services?**  
**A.** We work with multiple 3D contractors to ensure redundancy in coverage.

It is a common business practice in the all-hazards emergency response industry for companies to work together to get the job done. For example, during

the first days of the 2010 Deepwater Horizon oil spill, NVS conducted an unannounced notification exercise with our 3D contractors while conducting a full-scale deployment exercise with one of the 3D companies in attendance. All 3D contractors indicated they had the capability to respond to an agricultural emergency while responding to the oil spill at the same time.

**Q. How do I request 3D services during an animal disease event?**  
**A.** Call our 24/7 emergency hotline at 1-800-940-6524.

**Q. If I have questions about NVS or 3D services, who should I contact?**  
**A.** Email us at [nvs@aphis.usda.gov](mailto:nvs@aphis.usda.gov) with any questions. More information is also available on our Web site at [www.aphis.usda.gov/animal\\_health/emergency\\_management/nvs.shtml](http://www.aphis.usda.gov/animal_health/emergency_management/nvs.shtml).

USDA is an equal opportunity provider and employer.

United States Department of Agriculture • Animal and Plant Health Inspection Service • **Safeguarding American Agriculture**

**Source:** [https://www.aphis.usda.gov/animal\\_health/emergency\\_management/downloads/nvs\\_3d\\_services.pdf](https://www.aphis.usda.gov/animal_health/emergency_management/downloads/nvs_3d_services.pdf)

13-5

# USDA Avian Influenza Response: Mass Depopulation and Carcass Disposal

**Author/Organization:** USDA APHIS

**Overview:** As part of its safeguarding mission, the U.S. Department of Agriculture (USDA) protects the health of the Nation's livestock and poultry. USDA responds to major animal disease events, helping to keep dangerous diseases from spreading and threatening even more animals. USDA also works to reduce the economic impact of disease events. In responding to the detections, USDA must depopulate affected flocks to prevent the spread of this highly contagious disease to additional flocks and must safely dispose of all depopulated birds. USDA and State officials evaluate disposal options based on the size of the flock, local conditions, and applicable laws/regulations.

**Direct Access:** Visit the USDA APHIS site: [go.usdatraining.com/depopulation](https://go.usdatraining.com/depopulation)

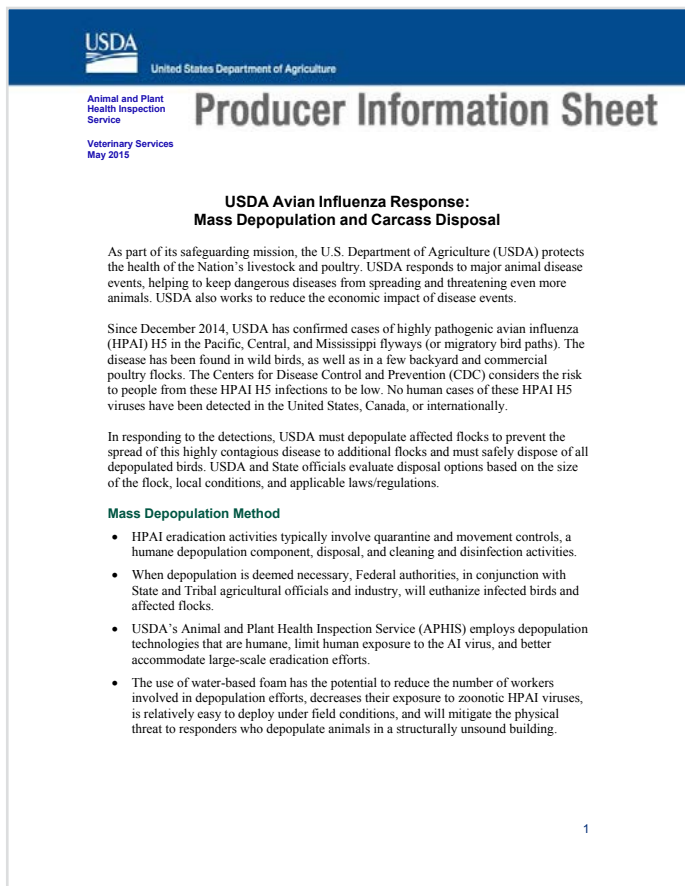

**USDA Avian Influenza Response:  
Mass Depopulation and Carcass Disposal**

As part of its safeguarding mission, the U.S. Department of Agriculture (USDA) protects the health of the Nation's livestock and poultry. USDA responds to major animal disease events, helping to keep dangerous diseases from spreading and threatening even more animals. USDA also works to reduce the economic impact of disease events.

Since December 2014, USDA has confirmed cases of highly pathogenic avian influenza (HPAI) H5 in the Pacific, Central, and Mississippi flyways (or migratory bird paths). The disease has been found in wild birds, as well as in a few backyard and commercial poultry flocks. The Centers for Disease Control and Prevention (CDC) considers the risk to people from these HPAI H5 infections to be low. No human cases of these HPAI H5 viruses have been detected in the United States, Canada, or internationally.

In responding to the detections, USDA must depopulate affected flocks to prevent the spread of this highly contagious disease to additional flocks and must safely dispose of all depopulated birds. USDA and State officials evaluate disposal options based on the size of the flock, local conditions, and applicable laws/regulations.

**Mass Depopulation Method**

- HPAI eradication activities typically involve quarantine and movement controls, a humane depopulation component, disposal, and cleaning and disinfection activities.
- When depopulation is deemed necessary, Federal authorities, in conjunction with State and Tribal agricultural officials and industry, will euthanize infected birds and affected flocks.
- USDA's Animal and Plant Health Inspection Service (APHIS) employs depopulation technologies that are humane, limit human exposure to the AI virus, and better accommodate large-scale eradication efforts.
- The use of water-based foam has the potential to reduce the number of workers involved in depopulation efforts, decreases their exposure to zoonotic HPAI viruses, is relatively easy to deploy under field conditions, and will mitigate the physical threat to responders who depopulate animals in a structurally unsound building.

1

**Biosecurity During Carcass Disposal**

If USDA determines that moving the carcasses to a landfill for disposal is the best available option, animal health officials will ensure this move is safe for both landfill operators and the general public, and that all necessary biosecurity steps are followed.

**General Carcass Disposal**

**Q. What are the carcass disposal options?**

A. There are a variety of safe methods for carcass disposal. These methods include composting, onsite burial, incineration, rendering, and landfilling.

**Q. How do animal health officials decide which disposal method to use?**

A. USDA and its State partners evaluate disposal methods based on a variety of factors, including the size of the flock, space requirements, associated costs, local conditions, and applicable laws/regulations. There are benefits and limitations to using each method.

- **Composting.** This method contains the virus to the farm and produces a soil amendment/fertilizer product. However, composting requires wide-open spaces and may not be feasible for all farming operations, such as egg layer facilities or other facilities where space is limited.
- **Burial.** On-farm carcass burial must be approved by the State environmental regulatory agency and may not be permitted if the water table is close to the ground surface.
- **Incineration.** Incineration is another method that can be safely used to dispose of carcasses. The limitation of this method is that the fuel requirements are substantial and can be costly.
- **Rendering.** This involves processing carcasses until they are reduced to water, fat or tallow, and meat or bone meal. It is very effective but requires additional safety precautions to ensure that the virus does not become aerosolized during the rendering process and transported throughout the plant. It also necessitates disruption of the plant's normal operations.
- **Landfilling.** Landfilling allows safe and efficient disposal of large quantities of carcasses. However, individual landfill managers may put restrictions on the type or quantity of materials they accept.

When necessary, USDA takes an integrated approach and uses a combination of some or all of these methods.

**Landfilling—Health and Safety Concerns**

**Q. Is landfilling an environmentally safe option for HPAI carcass disposal?**

A. Yes. Landfills are highly regulated by the U.S. Environmental Protection Agency (EPA) and—in many cases—individual States to ensure that disposed materials do not present a risk to human health and the environment. Under EPA and State regulations, landfills are located, designed, operated, and monitored to ensure protection of the environment from contaminants that might be present.

2

**Source:** [https://www.aphis.usda.gov/animal\\_health/downloads/animal\\_diseases/ai/QA-MassDepopCarcassDisposal.pdf](https://www.aphis.usda.gov/animal_health/downloads/animal_diseases/ai/QA-MassDepopCarcassDisposal.pdf)

# HPAI Response: Timeline, Eligibility, and Approval for Restocking

**Author/Organization:** USDA APHIS

**Overview:** *HPAI Response - Timeline, Eligibility, and Approval for Restocking* document provides guidance to State Animal Health Officials (SAHOs), USDA Animal and Plant Health Inspection Service (APHIS) Officials, and Incident Management Teams (IMTs) for the restocking of highly pathogenic avian influenza (HPAI)-infected commercial poultry premises. This includes the timeline to restocking and criteria that must be met for premises to restock.

**Direct Access:** Visit the USDA APHIS site: [go.usdatraining.com/criteriarestock](https://go.usdatraining.com/criteriarestock)

USDA Animal and Plant Health Inspection Service  
U.S. DEPARTMENT OF AGRICULTURE

## HPAI Response

### Timeline, Eligibility, and Approval for Restocking

February 28, 2022

Please note: These procedures may be revised as the situation develops.

#### DOCUMENT HISTORY & RELATED DOCUMENTS

This document updates and supersedes the following documents:

- Timeline to Restocking & Environmental Sampling Procedures
- Restocking Criteria for Previously Infected Premises.

Please also see the following, related policy documents ([www.aphis.usda.gov/fadprep](http://www.aphis.usda.gov/fadprep)):

- Protocol for Environmental Sample Collection and Testing for AI Virus
- Cleaning & Disinfection Basics (Virus Elimination).

#### INTENDED USE

This document provides guidance to State Animal Health Officials (SAHOs), USDA Animal and Plant Health Inspection Service (APHIS) Officials, and Incident Management Teams (IMTs) for the restocking of highly pathogenic avian influenza (HPAI)-infected commercial poultry premises. This includes the timeline for restocking and criteria that must be met for premises to restock.

For premises to restock after HPAI infection, they must meet the minimum time requirements, all criteria laid out in this document, **AND** be approved to restock. Being approved to restock indicates that in addition to finishing all the steps in the restocking process, the premises has met any additional criteria that may have been laid out by the State or APHIS, and that State and APHIS officials agreed in writing that the premises can be restocked.

#### BIOSECURITY MEASURES

All biosecurity practices currently in place on the premises (including use of personal protective equipment (PPE)) will be followed for activities discussed in this document, including sample collection for environmental testing and final inspection of the premises prior to quarantine release. The level of PPE needed for different activities (environmental sampling, for example) will be determined by the SAHOs and/or IMTs.

#### TIMELINE TO RESTOCKING OF PREVIOUSLY INFECTED PREMISES

The timelines provided below offer guidance on just the *steps, time, and sampling* it takes to reach the point to be eligible to begin the restocking process and, ultimately, approved to restock.

#### Timelines for Restocking for Premises Using Composting

Please see Figures 1 through 3 for the timelines on premises using composting. Figure 1 covers in-house composting, Figure 2 covers outdoor composting, and Figure 3 covers the combination of in-house/outdoor composting.

For premises using composting, environmental sampling inside the houses/barns occurs after the compost pile is complete and removed from inside the barns. For outdoor composting, environmental sampling inside the houses/barns can occur after the houses/barns have completed virus elimination.

1 of 5

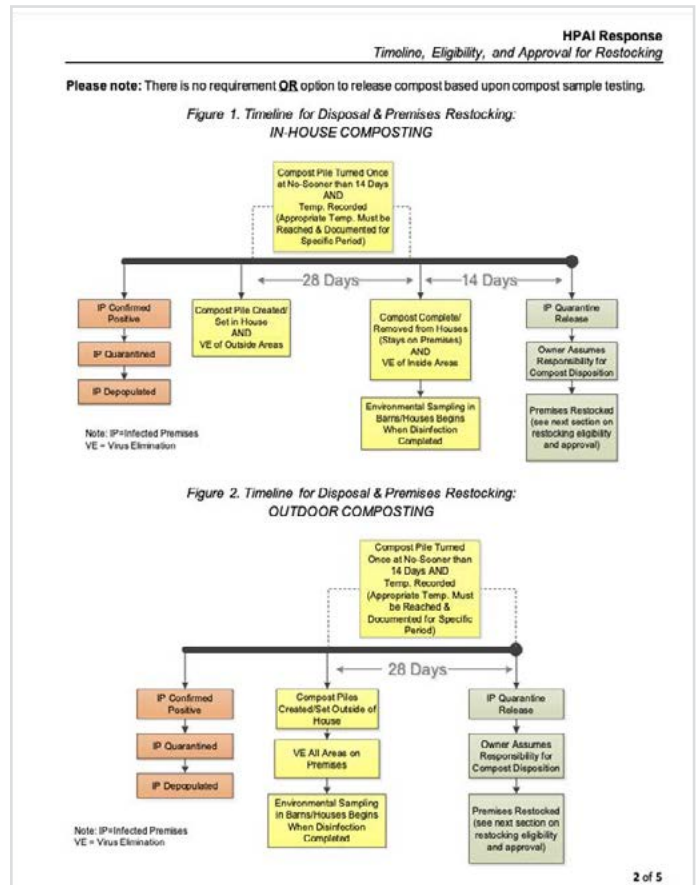

**Source:** [https://www.aphis.usda.gov/animal\\_health/emergency\\_management/downloads/hpai/criteriarestock.pdf](https://www.aphis.usda.gov/animal_health/emergency_management/downloads/hpai/criteriarestock.pdf)

# HPAI Response Mortality Composting Protocol for Avian Influenza Infected Flocks

---

**Author/Organization:** USDA APHIS

**Overview:** Composting is a biological heating process that results in the natural degradation of organic resources (such as poultry carcasses) by microorganisms. Composting has been successfully used throughout the United States for nearly two decades to control outbreaks of low pathogenicity avian influenza (LPAI) and highly pathogenic avian influenza (HPAI). Composting can be effective with most bird types and poultry house designs.

**Direct Access:** Visit the USDA APHIS site: [go.usdatraining.com/HPAI\\_composting](http://go.usdatraining.com/HPAI_composting)

**Source:** [https://www.aphis.usda.gov/animal\\_health/emergency\\_management/downloads/hpai/mortalitycompostingprotocol.pdf](https://www.aphis.usda.gov/animal_health/emergency_management/downloads/hpai/mortalitycompostingprotocol.pdf)



# Landfills and Highly Pathogenic Avian Influenza (HPAI) Response

**Author/Organization:** USDA APHIS

**Overview:** The *Landfills and Highly Pathogenic Avian Influenza (HPAI) Response* provides guidance on how disease outbreaks can be handled, the goals during a foreign animal disease (FAD) outbreak, and the role that landfills play during HPAI outbreaks. Providing statistics on today's commercial poultry production industry as well as specific HPAI outbreaks, demonstrates the clear need for proper disposal procedures and landfill management. The planning and operations of both disposal procedures and landfill management is explored in detail within this resource.

**Direct Access:** Visit the USDA APHIS site: [go.usdatraining.com/HPAI\\_landfills](https://go.usdatraining.com/HPAI_landfills)

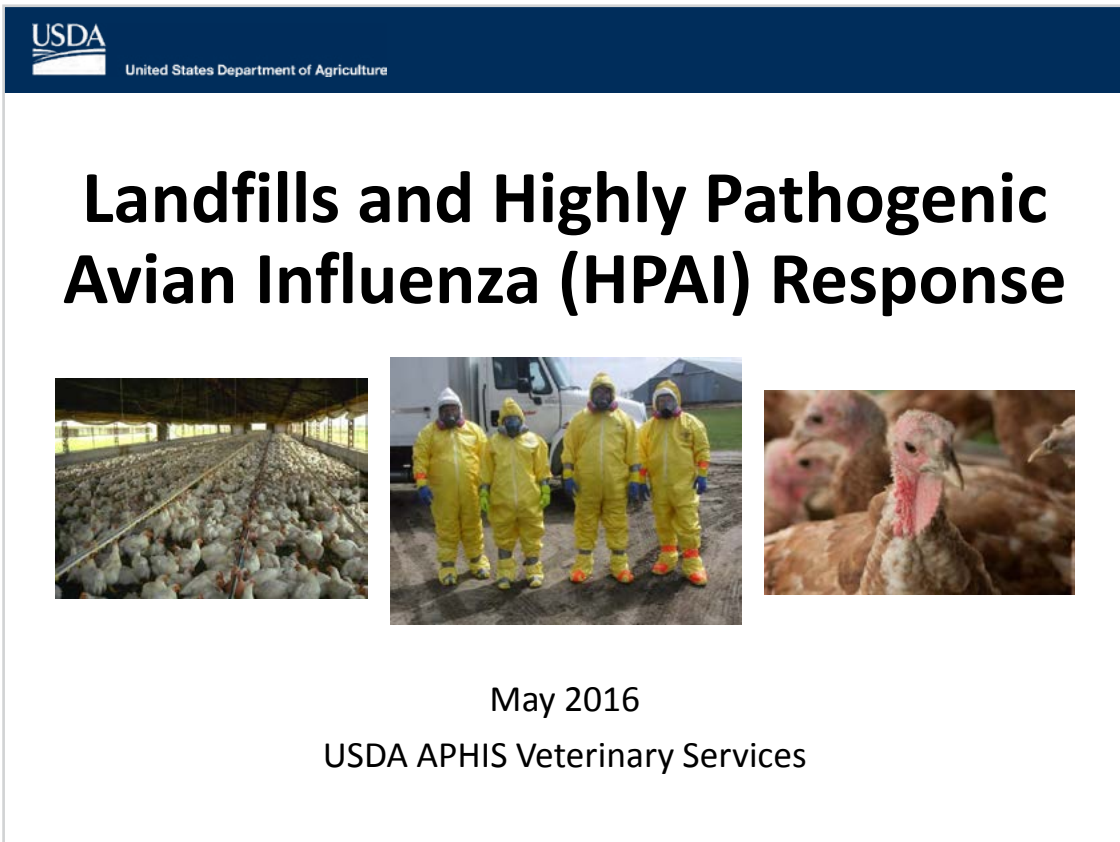

USDA  
United States Department of Agriculture

## Landfills and Highly Pathogenic Avian Influenza (HPAI) Response

May 2016  
USDA APHIS Veterinary Services

**Source:** [https://www.aphis.usda.gov/animal\\_health/emergency\\_management/downloads/hpai/landfillsandhpaireponse.pdf](https://www.aphis.usda.gov/animal_health/emergency_management/downloads/hpai/landfillsandhpaireponse.pdf)

# North American Renderers Association: Membership Directory

**Author/Organization:** North American Renderers Association (NARA)

**Overview:** The NARA Member Directory is a helpful networking tool for members and gives customers easy access to your business contact information. Active members include independent renderers and packer renderers, are sorted alphabetically, and include a key-code for the kinds of rendered products available. At the end of the alphabetic listing, Active members are also listed by state to find local producers of rendered products.

**Direct Access:** Visit the NARA site: [NARA Membership Directory](https://nara.org)

### 2023 NARA Officers

**Chairman:**  
Michael Smith  
Winchester, VA  
540-877-2590

**First Vice Chairman:**  
Michael Glenn  
BHT Resources  
Birmingham, AL  
205-252-1197

**Second Vice Chairman:**  
David Levine  
Smithfield  
Smithfield, VA  
970-978-6423

### 2023 NARA Regional Officers

EASTERN REGION	CENTRAL REGION	WESTERN REGION
<b>President:</b> Jody Ankin Smithfield 757-357-1368	<b>President:</b> Tom Beseman Central Bi-Products 800-733-6498	<b>President:</b> Andy Black Reno Rendering 800-733-6498
<b>Vice President:</b> Franklin Moore BHT ReSources 205-252-1197	<b>Vice President:</b> Robert Kaluzny Kaluzny Bros. 815-744-1453	<b>Vice President:</b> Vacant
<b>Secretary/Treasurer:</b> Tyler Nicholson National Beef Packing Company LLC 800-449-2333	<b>Secretary/Treasurer:</b> Vacant	<b>Secretary/Treasurer:</b> Chris Zacobini California Grain and Feed Association 916-441-2272

### 2023 Active Members

Producers of animal fats and proteins

<b>API Inc. - The Lauridsen Group Inc.</b> 2425 S.E. Oak Tree Court, Ankeny, IA 50021 Contact: Jerry Frankel Phone: 515-289-7600 Fax: 515-289-4360 Email: jerryfrankel@functionalproteins.com Products: Spray-dried blood and plasma products Region: Central	<b>API Inc. - Boone</b> 2621 Wornie Eisenhower Ave., Boone, IA 50036 Contact: Andy Etnyre Phone: 515-289-7688 Fax: 712-263-6772 Email: andy.etnyre@functionalproteins.com Products: Spray-dried blood and plasma products Region: Central	<b>API Inc. - Selma</b> 1451 West Noble St, Selma, NC 27576 Contact: Andy Etnyre Phone: 515-289-7688 Fax: 712-263-6772 Email: andy.etnyre@functionalproteins.com Products: Spray-dried blood and plasma products Region: Central
<b>API Inc. - Arion</b> 2248 Lincoln Way, Anon, IA 51520 Contact: Andy Etnyre Phone: 515-289-7688 Fax: 712-263-6772 Email: andy.etnyre@functionalproteins.com Products: Spray-dried blood and plasma products Region: Central	<b>API Inc. - Dubuque</b> 1300 Island Lane, PO Box 1398, Dubuque, IA 52003 Contact: Andy Etnyre Phone: 515-289-7688 Fax: 712-263-6772 Email: andy.etnyre@functionalproteins.com Products: Spray-dried blood and plasma products Region: Central	<b>API Inc. - Sublette</b> 1197 US Highway 83, Sublette, KS 67877 Contact: Andy Etnyre Phone: 515-289-7688 Fax: 712-263-6772 Email: andy.etnyre@functionalproteins.com Products: Spray-dried blood and plasma products Region: Central

## North American Renderers Association

# Membership Directory

**Boyer Valley Company**  
LGI Company  
2425 S.E. Oak Tree Court,  
Ankeny, IA 50021  
www.boyervalley.com  
Contact: Walter Lauridsen  
Phone: 515-289-7600  
Fax: 515-289-4360  
Email: walter.lauridsen@boyervalley.com  
Products: FBM, BM, FM, YG  
Region: Central

**Baker Commodities Inc. - Rochester**  
2268 Browncraft Boulevard,  
Rochester, NY 14625-1050  
Contact: Walter Gurschick  
Phone: 585-482-1880  
Fax: 585-654-7070  
Email: w.gurschick@bakercommodities.com  
Products: TG  
Region: Eastern

**Baker Commodities Inc. - Seattle**  
PO Box 58368,  
Seattle, WA 98138-1368  
Contact: Mike Bullert  
Phone: 206-243-7387  
Fax: 206-243-3412  
Email: mbullert@bakercommodities.com  
Products: EX, TG, MB, FGA, HI  
Region: Western

**Baker Commodities Inc. - Spokane**  
PO Box 11157,  
Spokane, WA 99211-1157  
Contact: Joe Jacobson  
Phone: 509-535-5435  
Fax: 509-536-3817  
Email: jjacobson@bakercommodities.com  
Products: SF, TG, HI, MB  
Region: Western

**Baker Commodities Inc. - Western Mass. Rendering Co. Inc.**  
94 Foster Road,  
Southwick, MA 01077  
www.westernmassrendering.com  
Contact: Judy Paquin  
Phone: 413-569-6512  
Fax: 413-569-6265  
Email: judy@wrmco.com  
Products: EX, SF, FGA, DT, TG  
Region: Eastern

**BHT ReSources**  
PO Box 1596, 700 Maple  
Street, Suite A,  
Birmingham, AL 35210  
Contact: T. Owen Vickers  
Phone: 205-252-1197  
Fax: 205-251-1522  
Email: tovickers@bht.com  
Products: TG, SF, FGA, HI,  
MB, BFB  
Region: Eastern

**Baker Commodities Inc. - Los Angeles**  
4020 Bandini Boulevard,  
Vernon, CA 90058-4274  
Contact: Shelton Wang  
Phone: 323-268-2801  
Fax: 323-268-5166  
Email: swang@bakercommodities.com  
Products: EX, RF, SF, TG, HI,  
MM, MB, FGA, ST  
Region: Western

**Brown Packing Co., Inc.**  
PO Box 130, 116 Willis Street,  
Galveston, TX 77542-0130  
www.allied-renewal.com  
Contact: Steven Blanton  
Phone: 864-489-5723  
Fax: 864-487-3210  
Email: sblanton@bropac.com  
Products: TG, SF, BM, MB, YG  
Region: Eastern

**Cargill - Headquarters**  
825 E. Douglas Ave.,  
Wichita, KS 67202  
www.cargill.com  
Contact: Kooper O'Brien  
Phone: 316-291-2500  
Email: Kooper\_O'Brien@cargill.com  
Products: EX, BM, DT, FGA, HI,  
MB, MM, SF, TG  
Region: Central

**Cargill - Dodge City**  
PO Box 1060,  
Dodge City, KS 67801  
Products: BM, DT, FGA, HI,  
MB, MM, SF, TG  
Region: Central

**Cargill - Fort Morgan**  
PO Box 4100,  
Fort Morgan, CO 80701  
Products: BM, DT, FGA, HI,  
MB, MM, SF, TG  
Region: Central

**Cargill - Friona**  
PO Box 579,  
Friona, TX 79035  
Products: BM, DT, FGA, HI,  
MB, MM, SF, TG  
Region: Central

**Cargill - Schuyler**  
PO Box 544,  
Schuyler, NE 68661  
Products: BM, DT, FGA, HI,  
MB, MM, SF, TG  
Region: Central

**Cargill - Spokane**  
PO Box 3850,  
High River, AB T1V 1P4,  
Canada  
Products: EX, BM, DT, FGA,  
HI, MB, MM, SF, TG  
Region: Western

**Cargill - Wyalusing**  
PO Box 188,  
Wyalusing, PA 18853  
Products: SF, TG, MB, BFB,  
EX, BM  
Region: Eastern

**Central Bi-Products**  
Farmers Union Industries LLC  
PO Box 319,  
Redwood Falls, MN 56283  
www.fuillc.com  
Contact: Glenn Jensen  
Phone: 507-644-6900  
Fax: 507-637-5409  
Email: gjensen@centralbi.com  
Products: FM, PB, SF, TG, HI,  
MM, MB, DT, BFF, FGA, BM,  
OT(Pet food)  
Region: Central

**Central Bi-Products**  
Farmers Union Industries LLC  
PO Box 359,  
Long Prairie, MN 56346  
Contact: Glenn Jensen  
Phone: 507-644-6900  
Fax: 507-637-5409  
Email: gjensen@centralbi.com  
Products: FM, PB, SF, TG, HI,  
MM, MB, FM, BFF, FGA, BM,  
OT(Pet food)  
Region: Central

**Central Bi-Products**  
Farmers Union Industries LLC  
1842 Highway 4,  
Etherville, IA 51334  
Contact: Glenn Jensen  
Phone: 507-644-6900  
Email: gjensen@centralbi.com  
Products: FM, PB, SF, TG, HI,  
MM, MB, FM, BFF, FGA, BM,  
OT(Pet food)  
Region: Central

**Coast Packing Company**  
3275 East Vernon Avenue,  
Vernon, CA 90058  
www.coastpacking.com  
Contact: Eric Gustafson  
Phone: 323-277-7700  
Email: eric@coastpacking.com  
Products: TG, SF, LG, RF  
Region: Western

**Darling Ingredients Inc. - Headquarters**  
5601 N. MacArthur Blvd.,  
Irving, TX 75038  
www.darlinginc.com  
Phone: 972-717-0300  
Region: Central, Western,  
Eastern

**Darling Ingredients Inc. - Nature Safe**  
4221 Alexandria Pike,  
Cold Spring, KY 41076  
Contact: Mike Manning  
Phone: 859-344-2230  
Email: mmanning@darlinginc.com  
Products: Organic fertilizers  
Region: Eastern

www.nara.org

NARA Membership Directory

Render April 2023 27

www.nara.org

NARA Membership Directory

28 April 2023 Render

www.nara.org

NARA Membership Directory

NARA Membership Directory

www.nara.org

NARA Membership Directory

www.nara.org

**Source:** <https://nara.org/wp-content/uploads/2023/03/NARA-2023-membership-directory-final.pdf>

# Risk Assessment for the Transmission of Foot and Mouth Disease via Movement of Swine and Cattle Carcasses from FMD-infected Premises to a Disposal Site

**Author/Organization:** University of Minnesota

**Overview:** The risk assessment proactively evaluated the risk of infecting susceptible livestock by the movement of Foot and Mouth Disease (FMD) infected carcasses (swine and cattle) from FMD infected premises. The risk assessment evaluated the most up-to-date available science and solicited opinion from experts when data was lacking. This risk assessment was proactive in nature and the scenarios, pathways and depopulation practices assessed were based on the current practices and regulations applicable during an animal disease outbreak in the US.

**Direct Access:** Visit the USDA APHIS site: [go.usdatraining.com/UMRA](http://go.usdatraining.com/UMRA)

## Risk Assessment for the Transmission of Foot and Mouth Disease via Movement of Swine and Cattle Carcasses from FMD-infected Premises to a Disposal Site

February 2014



UNIVERSITY OF MINNESOTA

CENTER FOR ANIMAL HEALTH  
AND FOOD SAFETY

*Prepared by the University of Minnesota  
Center for Animal Health and Food Safety for  
West Texas A&M University under a  
Cooperative Agreement from USDA APHIS  
funded by DHS S&T*

Risk Assessment for the Transmission of Foot and Mouth Disease via Movement of Swine and Cattle Carcasses from FMD-infected Premises to a Disposal Site

Page 1

### Table of Contents

List of Figures .....	4
Abbreviations .....	7
Definitions .....	8
Executive Summary .....	13
1. Background .....	14
2. Scope .....	15
3. Assumptions .....	16
4. Overview of data analysis approaches .....	17
5. FMD Depopulation Procedures and Carcass Movement .....	19
5.1. Standard Operating Procedures for FMD Depopulation .....	19
5.2. Types of Transportation .....	23
5.3. Transportation Regulations .....	26
5.4. Pathway analysis for Carcass Movement .....	27
6. Hazard identification .....	28
6.1. Background .....	28
6.2. Virus Characteristics .....	29
6.3. Host range of FMD .....	29
6.4. Transmission .....	30
6.5. Incubation Period .....	30
6.6. Clinical Signs .....	31
6.7. Concentration of virus in tissues, secretions, excretions .....	31
6.8. Environmental Persistence .....	32
7. Entry Assessment .....	32
7.1. Likelihood that swine and cattle carcasses moved from a FMD positive premise will contain an infective dose .....	33
7.1.1. Time for FMD detection .....	34
7.1.2. Time from detection to depopulation .....	36
7.1.3. Number of viremic livestock after depopulation .....	39
7.1.4. FMDv concentration in swine and cattle viremic carcasses .....	41

Risk Assessment for the Transmission of Foot and Mouth Disease via Movement of Swine and Cattle Carcasses from FMD-infected Premises to a Disposal Site

Page 2

**Source:** <https://conservancy.umn.edu/bitstream/handle/11299/193839/FMD%20Carcass%20Movement%20ORA%20Final%20UMN%20CAHFS%20021814.pdf>