

Use of Fatty Acid Profiles to Distinguish between Selected Game Fish and Farm-Raised Channel Catfish

Randal S. Stahl

USDA APHIS Wildlife Services, National Wildlife Research Center, Fort Collins, Colorado

Brian S. Dorr and Scott C. Barras

USDA APHIS Wildlife Services, National Wildlife Research Center, Mississippi Field Station, Mississippi State, Mississippi

John J. Johnston

USDA APHIS Wildlife Services, National Wildlife Research Center, Fort Collins, Colorado

ABSTRACT: Establishing the impact of double-crested cormorants on commercial farmed channel catfish production using visual assessments of cormorant GI tract contents is complicated by, first, the difficulty in distinguishing between partially digested fish of different species, and secondly, the possibility that the fish appearing in the diet have a natural source of origin. We analyzed the fatty acid profiles of selected game fish and farm-raised channel catfish to establish profiles that may allow for the application of this technique in establishing cormorant foraging patterns. We obtained for analysis farm-raised channel catfish from three commercial producers and one research facility. For comparison, we also collected channel catfish, gizzard shad, green sunfish, bluegill, and largemouth bass from natural waterways. A total of 12 sample groups were analyzed. Lipids were extracted using a modified Folch extraction and trans-esterified in 3N HCl in methanol. The resultant fatty acids were identified using gas chromatography/mass spectrometry. The relative mass percent distributions for the major fatty acids were calculated for each individual. A classification tree analysis was performed to identify groupings based on these individual fish distributions. These preliminary results have led us to conclude that it is possible to distinguish not only between farm-raised channel catfish and game fish in the diet of cormorants, but that it may be possible to identify the source of the farm-raised channel catfish in the diet. The management implications are that it may be possible, based on fatty acid analysis of GI tract contents of cormorants, to assess the actual impact of birds from a given roost or colony on a specific channel catfish producer.

KEY WORDS: aquaculture, channel catfish, damage assessment, depredation, double-crested cormorant, fatty acid, fish, *Phalacrocorax auritus*

Proc. 22nd Vertebr. Pest Conf. (R. M. Timm and J. M. O'Brien, Eds.)
Published at Univ. of Calif., Davis. 2006. Pp. 389-392.

INTRODUCTION

Traditional methods for determining diet have relied on visually identifying the contents of the gastro-intestinal (GI) tract, and the degree to which the components in the diet have been digested often complicates this assessment. Establishing dietary composition by monitoring fatty acid profiles for organisms has become increasingly common as a means for overcoming these difficulties and determining the relative importance of a component of the diet in wildlife (Iverson *et al.* 1997). Mammals can only synthesize a relatively small number of fatty acids (Cook 1985) and they cannot metabolize long chain fatty acids (C>28) through β -oxidation (Sprecher *et al.* 1995). Thus, the fatty acid profile of an organism tends to reflect the diet of that organism.

Double-crested cormorants (*Phalacrocorax auritus*, hereafter 'cormorant') feed on a wide variety of fish species, typically in proportion to their availability (Hatch and Weseloh 1999). Documented prey species include channel catfish (*Ictalurus punctatus*, hereafter 'catfish'), gizzard shad (*Dorosma cepedianum*), green sunfish (*Lepomis cyanellus*), bluegill (*Lepomis macrochirus*), white crappie (*Pomoxis annularis*), and largemouth bass (*Micropterus salmoides*) (Glahn *et al.* 1998). When cormorants feed on farm-raised catfish, they have significant impacts on the productivity of the farm (Glahn and Dorr 2002, Glahn *et al.* 2003). The increase in hectares devoted to catfish aquaculture production, and

the associated losses due to cormorant depredation, have resulted in increasing concern with economic impacts of depredation and a need to better evaluate those impacts (Taylor and Dorr 2003).

Cormorants forage in a variety of locations during winter, usually within 16 km of their roosts (King *et al.* 1995). Cormorants roosting near aquaculture facilities may include these sites in their daily foraging bouts. Dorr *et al.* (2004) indicated that cormorants using roosts distant from aquaculture facilities may preferentially feed from natural water bodies near their roosts. Management approaches have included strategies for dispersing roosts near aquaculture facilities, in hopes of moving cormorants to areas where their feeding activities do not impact aquaculture (Mott *et al.* 1992, 1998).

Wild fish have been shown to reflect the fatty acid profiles of their diets. For example, this was demonstrated for Atlantic cod (Kirsch *et al.* 1998). It was also possible, by determining fatty acid profiles, to distinguish between the targeted fish and the diet of the targeted fish (Kirsh *et al.* 1998). With regard to assessing a cormorant's diet, this is important, as a desirable sport fish may feed on commercially less desirable fish also consumed by the cormorant. These studies also suggest the possibility of identifying whether the sources of fish in the cormorant diet are from commercial aquaculture facilities or natural water bodies.

We determined the fatty acid profiles for select game

fish and farm-raised channel catfish as a first step for determining if alternative techniques for identifying cormorant diets can be developed. This may aid in the identification of birds impacting aquaculture facilities and ultimately in quantifying the impacts to facilities located near cormorant roosts. We used an organic solvent extraction of the fish tissue, followed by analysis of the extract with gas chromatography/mass spectrometry. The relative mass abundances of select fatty acids were established as a profile representative for that fish species and source (wild-caught or farm-raised). These profiles were compared using classification and regression tree analysis to establish the levels of key fatty acids that would provide a basis for potentially distinguishing between the fish.

METHODS

Gizzard shad ($n=6$), green sunfish ($n=5$), bluegill ($n=6$), and largemouth bass ($n=6$) were collected from waterways and ponds in Mississippi. In addition, gizzard shad ($n=6$) and sunfish ($n=6$) were collected from commercial fishponds in Mississippi. Channel catfish fingerlings were obtained from three commercial producers (Producer A, $n=6$; Producer B, $n=7$; Producer C, $n=10$) and one research facility (fingerlings, $n=10$; larger catfish, $n=9$), all located in Mississippi. Wild-caught channel catfish ($n=6$) were also collected from waterways in Mississippi for comparison. The fish were frozen for transport and storage.

Lipids were extracted from replicate tissue samples from the dorsal muscle tissue of each fish sampled using a modified Folch extraction (Hamilton *et al.* 1992). The fatty acids were trans-esterified in 3N HCl in methanol and identified using gas chromatography/mass spectrometry (Agilent 5890 gas chromatograph/6890 mass spectrometer). Retention times and fragmentation patterns for each fatty acid were established using a Supelco 37 FAME standard on an Agilent DB-225 column (10 m length, 0.1 mm id, 0.1 μ m film).

Key fatty acids were designated as fatty acids with average relative abundances greater than 1% in one or more fish species/sources. The profiles generated for each of the individual fish were based on the mean of three replicate samples. The profiles for each individual fish were analyzed by classification and regression tree analysis using the tree procedure in R (R Foundation for Statistical Computing, Vienna, Austria).

RESULTS

The key fatty acids we determined to be present in the fish sample we analyzed at a concentration greater than 1% in at least one fish species/source were: myristic acid (C14:0); pentadecanoic acid (C15:0); palmitic acid (C16:0); palmitoleic acid (C16:1); heptadecanoic acid (C17:0); *cis*-10-heptadecanoic acid (C17:1); stearic acid (C18:0); oleic acid (C18:1n9); linoleic acid (C18:2n6); γ -linolenic acid (C18:3n6); arachadonic acid (C20:4n6); *cis*-13,16-docosadienoic acid (C22:2); nervonic acid (C24:1); and *cis*-4,7,10,13,16,19-docosahexaenoic acid (C22:6n3). The notation in the parenthesis reflect the number of carbon atoms in the fatty acid (C#), the number of unsaturated (double) bonds in the carbon chain

(: #), and the position of the last unsaturated bond, counted from the methyl end of the carbon chain (n#). This notation, instead of the common name, is used to identify the fatty acids.

The mean relative fatty acid mass percent profiles for the 14 key fatty acids across the 12 different classifications of fish showed wide ranges of relative abundance (Figures 1, 2, and 3). The 3 fatty acids that stand out with wide ranges across the 12 classifications were C16:0, C18:1n9, and C22:6n3.

The individual fish profiles were used in a classification and regression tree analysis (Figure 4) to establish which of the fatty acids would be most discriminating for classification of a profile as one of the 12 categories of fish. To verify the classification scheme, the fish data used to construct the tree were analyzed with the tree.

DISCUSSION

When we initiated this work, we anticipated the likelihood that it would be possible to distinguish between catfish from natural water bodies and those from aquaculture facilities. However, in comparing the fingerling data (Figure 2), we were surprised to see how

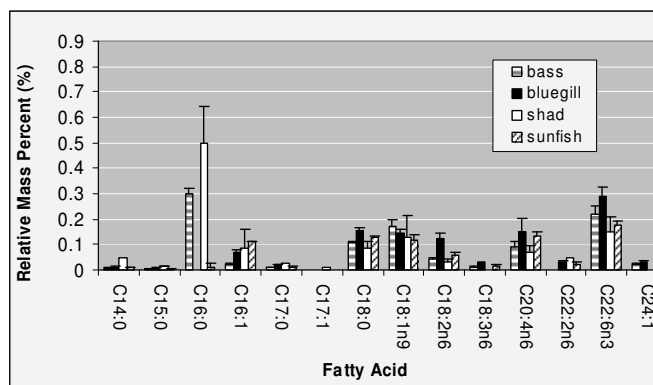

Figure 1. The mean relative mass percent for designated key fatty acids for large mouth bass, bluegill, gizzard shad, and green sunfish. The error bars are 1 standard deviation.

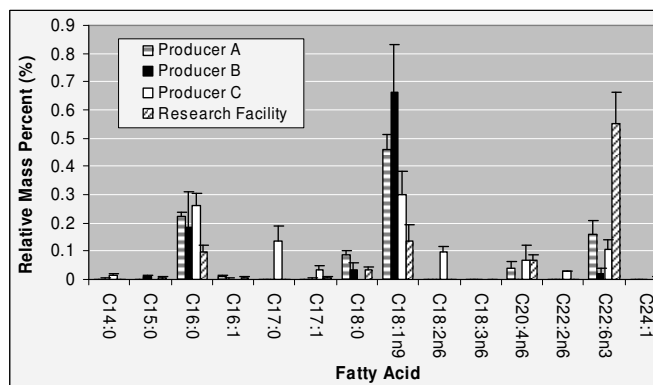

Figure 2. The mean relative mass percent for designated key fatty acids for channel catfish fingerlings from three different commercial producers and a research facility in Mississippi. The error bars are 1 standard deviation.

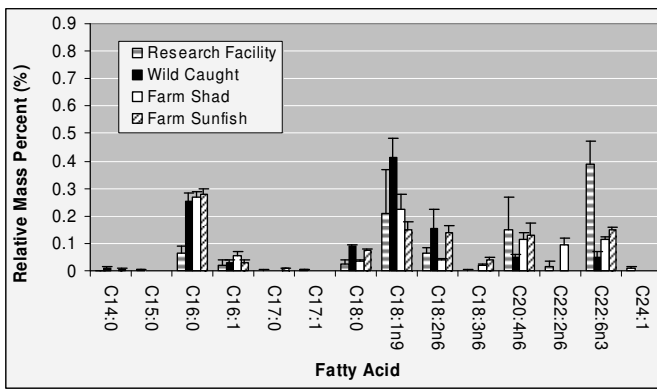

Figure 3. The mean relative mass percent for designated key fatty acids for channel catfish raised at a research facility, or wild-caught, compared to gizzard shad and green sunfish obtained from commercial fish ponds in Mississippi. The error bars are 1 standard deviation.

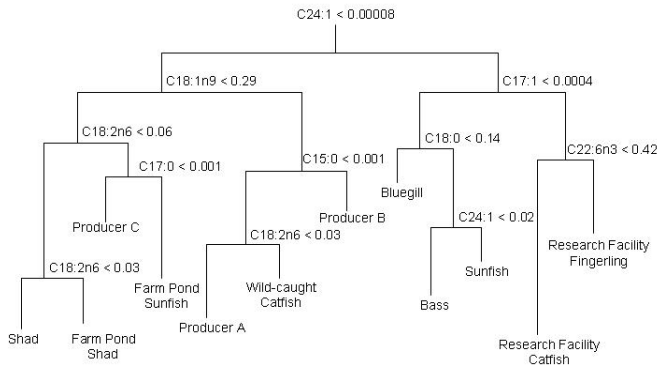

Figure 4. The classification and regression tree resulting from the analysis of the 83 individual fish profiles.

variable the profiles were, based on source of origin between the aquaculture facilities.

The classification and regression tree analysis we performed established differences between categories based on values with the lowest magnitude. The ‘root’ of the tree has a very small value, barely distinguishable from zero. This statistical analysis method allowed the same fatty acid to appear more than once in the tree when establishing a branch leading to a new classification category. Out of the 14 fatty acids used to construct the classification scheme, only 8 were used to establish tree branch points: C15:0, C17:0, C17:1, C18:0, C18:1n9, C18:2n6, C22:6n3, and C24:1.

The classification tree (Figure 4) was used by comparing the relative abundance of the specified fatty acid at a given branch point. For example, if the fish being classified had a relative abundance of the designated fatty acid at a branch point less than that listed at the node, take the left branch, otherwise take the right branch. This process was continued iteratively, moving to successively lower branches of the tree until a classification category was reached. The classification tree in Figure 4 properly classified 78 (93%) out of the 83 fish used to construct it. The mis-classifications all involved the origin of fingerlings or catfish, and none

were at the species level of classification. Thus, this approach would appear to provide a robust method for distinguishing channel catfish from other game fish in the diets of cormorants. The details of the mis-classifications were as follows: two fingerlings from Producer C classified as wild catfish, one fingerling from Producer B classified as a catfish from the research facility, two research facility catfish classified as fingerlings from the research facility, and one research facility fingerling classified as a fingerling from a commercial producer. The classification success rate between sources was still better than 80% and generally around 90%. The method should provide significant insight into the source of the catfish being depredated.

SUMMARY

These preliminary results lead us to conclude that fatty acid profiles obtained from fish may be useful both in establishing the magnitude of cormorant depredation of commercial channel catfish at production facilities and the source of the birds committing the depredation. Differences within species of fish further lead us to conclude that it may be possible to establish the origin of the depredated catfish to the specific farm. These analyses can be applied initially to the GI tract contents of cormorants, when such samples are collected for diet studies. Future work should examine profiles for other diet items that may be used frequently by cormorants in aquaculture production areas. Follow-up studies will examine fatty acid profiles in cormorants during controlled feeding studies. It may be possible to use the fatty acid profile of the birds to directly assess the degree and prevalence of catfish depredation in localized cormorant populations. Given this knowledge, efforts to mitigate losses through management of cormorant roost sites could be targeted to those identified as sources of birds depredating aquaculture facilities. Additionally, establishment of fatty acid profiles and insights into cormorant diet have important implications with respect to modeling regional economic impacts of cormorant depredation on the catfish aquaculture industry.

ACKNOWLEDGEMENTS

We thank the commercial catfish producers that supported this work by making catfish samples available for this study. P. Fioranelli, K. Hanson, S. Lemmons, R. Singleton, and S. Woodruff provided valuable field assistance. C. Furcolow provide valuable assistance in preparing and extracting the fish samples. We also thank the Mississippi Agricultural and Forestry Experiment Station and the Noxubee National Wildlife Refuge for their support and assistance in collecting catfish samples.

LITERATURE CITED

- COOK, H. W. 1985. Fatty acid desaturation and chain elongation in eukaryotes. Pp. 181-211 *in*: D. E Vance and J. E Vance (Eds.), *Biochemistry of Lipids and Membranes*. Benjamin/Cummings, Menlo Park, CA.
- DORR, B. S., D. T. KING, M. E. TOBIN, J. B. HARREL, AND P. L. SMITH. 2004. Double-crested cormorant movements in relation to aquaculture in eastern Mississippi and western Alabama. *Waterbirds* 27:147-154.

- GLAHN, J. F., AND B. S. DORR. 2002. Captive double-crested cormorant *Phalacrocorax auritus* predation on channel catfish *Ictalurus punctatus* fingerlings and its influence on single-batch cropping production. *World Aquacul. Soc. J.* 33:85-93.
- GLAHN, J. F., J. B. HARREL, AND C. VYLES. 1998. The diet of wintering double-crested cormorants feeding at lakes in the southeastern United States. *Colonial Waterbirds* 21:431-437.
- GLAHN, J. F., S. J. WERNER, T. HANSON, AND C. R. ENGLE. 2003. Cormorant depredation losses and their prevention at catfish farms: economic considerations. Pp. 138-146 *in*: L. Clark (Ed.). *Human Conflicts with Wildlife: Economic Considerations*. Proceedings of the Third NWRC Special Symposium, 1-3 August 2000. USDA APHIS National Wildlife Research Center, Fort Collins, CO.
- HAMILTON, S., R. J. HAMILTON, AND P. A. SEWELL. 1992. Extraction of lipids and derivative formation. Pp. 13-64 *in*: R. J. Hamilton and S. Hamilton (Eds.), *Lipid Analysis: A Practical Approach*. Oxford University Press, New York, NY.
- HATCH, J. J., AND D. V. WESELOH. 1999. Double-crested cormorant (*Phalacrocorax auritus*). No. 441 *in*: A. Poole and F. Gill (Eds.), *The Birds of North America*. The Birds of North America, Inc., Philadelphia, PA.
- IVERSON, S. J., K. J. FROST, AND L. F. LOWRY. 1997. Fatty acid signatures reveal fine scale structure of foraging distribution of harbor seals and their prey in Prince William Sound, Alaska. *Marine Ecology Program Series* 151:255-271.
- KING, D. T., J. F. GLAHN, AND K. J. ANDREWS. 1995. Daily activity budgets and movements of winter roosting double-crested cormorants determined by biotelemetry in the Delta region of Mississippi. *Colonial Waterbirds* 18 (Special Publ. 1):152-157.
- KIRSCH, P. E., S. J. IVERSON, W. D. BOWEN, S. R. KERR, AND R. G. ACKMAN. 1998. Dietary effects on the fatty acid signature of whole Atlantic cod (*Gadus morhua*). *Can. J. Fisheries Aquatic Sci.* 55:1378-1386.
- MOTT, D. F., K. J. ANDREWS, AND G. A. LITTAUER. 1992. An evaluation of roost dispersal for reducing cormorant activity on catfish ponds. *Proc. Eastern Wildl. Damage Manage. Conf.* 5:205-211.
- MOTT, D. F., J. F. GLAHN, P. L. SMITH, D. S. REINHOLD, K. J. BRUCE, AND C. A. SLOAN. 1998. An evaluation of winter roost harassment for dispersing double-crested cormorants away from catfish production areas in Mississippi. *Wildl. Soc. Bull.* 26:584-591.
- SPRECHER, H., D. L. LUTHRIA, B. S. MOHAMMED, AND S. P. BAYKOUSHEVA. 1995. Reevaluation of the pathways for the biosynthesis of polyunsaturated fats. *J. Lipid Res.* 36: 2471-2477.
- TAYLOR II, J. D., AND B. DORR. 2003. Double-crested cormorant impacts to commercial and natural resources. *Proc. Wildl. Damage Manage. Conf.* 10:43-51.